

PROJECT INFORMATION

SCOPE OF WORK: REPLACE (3) EXISTING ANTENNAS WITH (3) NEW ANTENNAS ON AN EXISTING SMOKESTACK. INSTALL FIBER AND POWER CONDUITS, AND INSTALL ADDITIONAL EQUIPMENT ON PROPOSED EQUIPMENT PAD.

SITE ADDRESS: BRIDGE STREET
EXETER, NH 03833

LATITUDE: 42° 58' 56.96" (NAD 83)*
LONGITUDE: 70° 56' 44.99" (NAD 83)*
* PER AT&T

JURISDICTION: TOWN OF EXETER

CURRENT USE: TELECOMMUNICATIONS FACILITY
PROPOSED USE: TELECOMMUNICATIONS FACILITY

NAME OF APPLICANT: AT&T MOBILITY
550 COCHITUATE ROAD
SUITES 13&14
FRAMINGHAM, MA 01701

TOWER OWNER: N/A
TOWER NUMBER: N/A

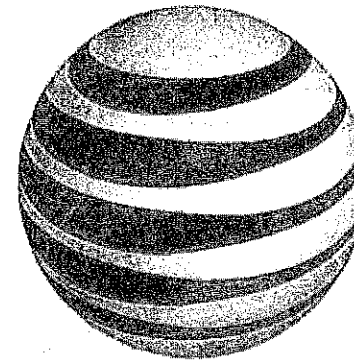

at&t
Mobility

SITE NAME: AWE - EXETER MILL
SITE NUMBER: NH2113

VICINITY MAP

DIRECTIONS: TAKE ROUTE 101 TO EXETER/ROUTE 108 (EXIT 10). AT END OF EXIT, TAKE ROUTE 108 SOUTH TURN RIGHT ON ROUTE 27/111. TURN RIGHT ONTO PLEASANT ST. BEFORE BRIDGE. TURN LEFT ONTO STRING BRIDGE STREET. THE SITE WILL BE ON THE LEFT.

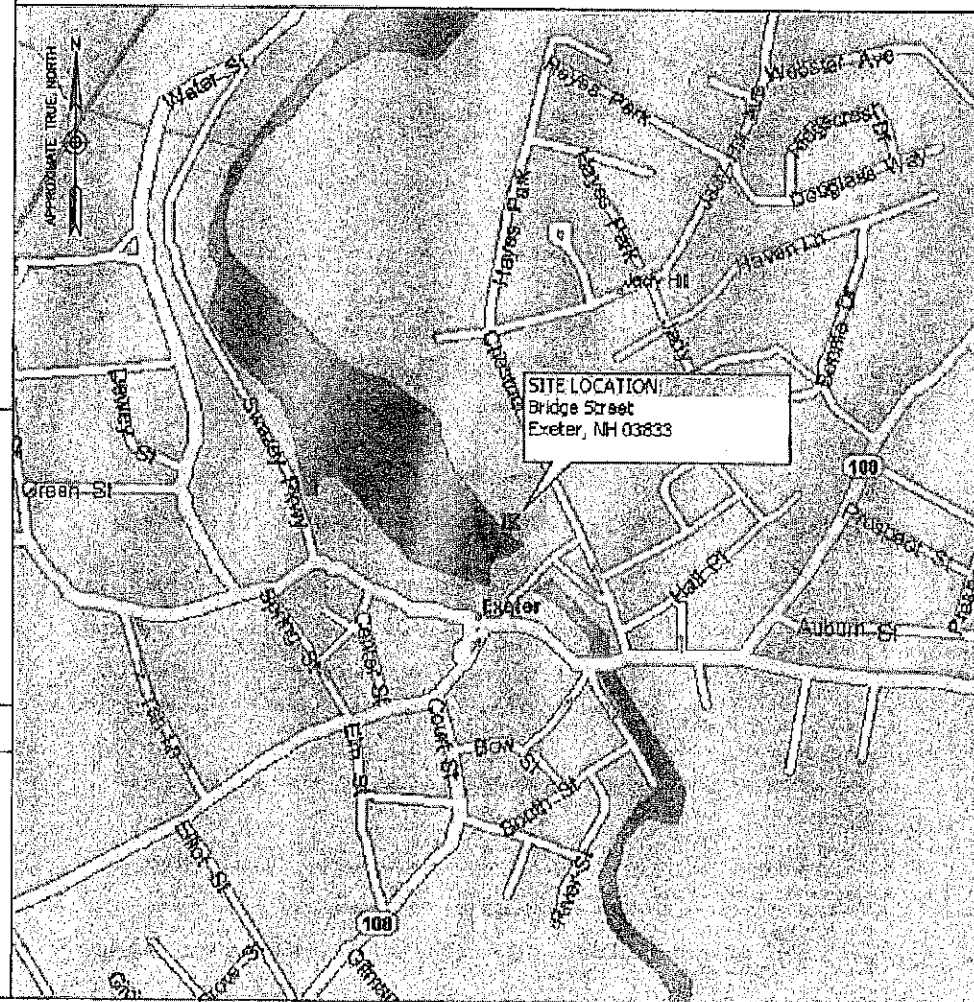

APPLICABLE BUILDING CODES AND STANDARDS

CONTRACTOR'S WORK SHALL COMPLY WITH PROJECT STANDARD NOTES, SYMBOLS AND DETAILS (SEE DRAWING INDEX FOR STANDARD NOTES AND DETAILS INCLUDED WITH TYPICAL DRAWING PACKAGE). CONTRACTOR WORK SHALL COMPLY WITH ALL APPLICABLE NATIONAL, STATE, AND LOCAL CODES AS ADOPTED BY THE LOCAL AUTHORITY HAVING JURISDICTION (AHJ) FOR THE LOCATION. THE EDITION OF THE AHJ ADOPTED CODES AND STANDARDS IN EFFECT ON THE DATE OF CONTRACT AWARD SHALL GOVERN THE DESIGN.

BUILDING CODE:
INTERNATIONAL BUILDING CODE (IBC 2009)

ELECTRICAL CODE:
NATIONAL ELECTRICAL CODE (NEC 2011)

CONTRACTOR'S WORK SHALL COMPLY WITH THE LATEST EDITION OF THE FOLLOWING STANDARDS.
AMERICAN CONCRETE INSTITUTE (ACI) 318, BUILDING CODE REQUIREMENTS FOR STRUCTURAL CONCRETE
AMERICAN INSTITUTE OF STEEL CONSTRUCTION (AISC), MANUAL OF STEEL CONSTRUCTION, ASD, NINTH EDITION
TELECOMMUNICATIONS INDUSTRY ASSOCIATION (TIA) 222-G, STRUCTURAL STANDARDS FOR STEEL ANTENNA TOWER AND ANTENNA SUPPORTING STRUCTURES
TIA 607, COMMERCIAL BUILDING GROUNDING AND BONDING REQUIREMENTS FOR TELECOMMUNICATIONS

INSTITUTE FOR ELECTRICAL AND ELECTRONICS ENGINEERS (IEEE) 81, GUIDE FOR MEASURING EARTH RESISTIVITY, GROUND IMPEDANCE, AND EARTH SURFACE POTENTIALS OF A GROUND SYSTEM
IEEE 1100 (1999) RECOMMENDED PRACTICE FOR POWERING AND GROUNDING OF ELECTRONIC EQUIPMENT

IEEE C62.41, RECOMMENDED PRACTICES ON SURGE VOLTAGES IN LOW VOLTAGE AC POWER CIRCUITS (FOR LOCATION CATEGORY "C3" AND "HIGH SYSTEM EXPOSURE")

TELCORDIA GR-1503, COAXIAL CABLE CONNECTIONS

ANSI T1.311, FOR TELECOM - DC POWER SYSTEMS - TELECOM, ENVIRONMENTAL PROTECTION

FOR ANY CONFLICTS BETWEEN SECTIONS OF LISTED CODES AND STANDARDS REGARDING MATERIAL, METHODS OF CONSTRUCTION, OR OTHER REQUIREMENTS, THE MOST RESTRICTIVE REQUIREMENT SHALL GOVERN. WHERE THERE IS CONFLICT BETWEEN A GENERAL REQUIREMENT AND A SPECIFIC REQUIREMENT, THE SPECIFIC REQUIREMENT SHALL GOVERN.

DRAWING INDEX

REV

T01	TITLE SHEET	1
G01	GENERAL NOTES	1
C01	PROPOSED SITE PLAN & CONSTRUCTION DETAILS	1
C02	PROPOSED ELEVATION & CONSTRUCTION DETAILS	1
E01	GROUNDING DETAILS	1

THIS DOCUMENT WAS DEVELOPED TO REFLECT A SPECIFIC SITE AND ITS SITE CONDITIONS AND IS NOT TO BE USED FOR ANOTHER SITE OR WHEN OTHER CONDITIONS PERTAIN. REUSE OF THIS DOCUMENT IS AT THE SOLE RISK OF THE USER.

STRUCTURAL NOTE:

- AS REQUIRED UNDER TIA/EIA 222G -- STANDARD, SAI COMMUNICATIONS SHALL PROVIDE A STRUCTURAL ANALYSIS OF THE TOWER PREPARED BY A LICENSED NEW HAMPSHIRE STRUCTURAL ENGINEER CERTIFYING THAT, THE EXISTING TOWER AND ANY REQUIRED IMPROVEMENTS AND REINFORCEMENTS HAVE SUFFICIENT CAPACITY TO SUPPORT ALL EXISTING AND PROPOSED ANTENNAS, SUPPORTS AND APPURTENANCES AND COMPLIES WITH THE CURRENT NEW HAMPSHIRE STATE BUILDING CODE AND EIA/TIA CRITERIA. THE CONTRACTOR IS RESPONSIBLE TO CONFIRM THAT ANY IMPROVEMENTS AND REINFORCEMENTS REQUIRED BY THE STRUCTURAL ANALYSIS CERTIFICATION ARE PROPERLY INSTALLED PRIOR TO THE ADDITION OF ANTENNAS, SUPPORTS AND APPURTENANCES PROPOSED ON THESE DRAWINGS OR OTHERWISE NOTED IN THE STRUCTURAL ANALYSIS.

CONTACT & UTILITY INFORMATION

CONTACT	CONTACT	COMPANY	PHONE NO.
ENGINEERING:	DAMIAN SCHMALZ	DEWBERRY	(617) 695-3400
SAC:	MATT McQUAID	SAI COMMUNICATIONS	(508) 560-3718
CONST.:	ADAM CORSI	SAI COMMUNICATIONS	(978) 490-7234
UTILITIES			
POWER:		PSNH	(800) 662-7764
TELCO:		FAIRPOINT COMMUNICATIONS	(866) 984-3001

Dewberry
Dewberry Engineers Inc.
280 SUMMER ST.
10TH FLOOR
BOSTON, MA 02210
PHONE: 617.695.3400
FAX: 617.695.3310

SAI communications
22 KEEWAYDIN DRIVE
SALEM, NH 03079

**AWE-EXETER MILL
SITE NO. NH2113**

BRIDGE STREET
EXETER, NH 03833



at&t
Mobility

550 COCHITUATE ROAD
SUITES 13 & 14
FRAMINGHAM, MA 01701

NO.	DATE	REVISIONS	BY	CHK	APP'D
1	11/09/12	FOR CONSTRUCTION	OAS	OAS	PPB
0	07/23/12	FOR REVIEW	OAS	OAS	PPB

SCALE: AS SHOWN DESIGNED BY: OAS DRAWN BY: MR

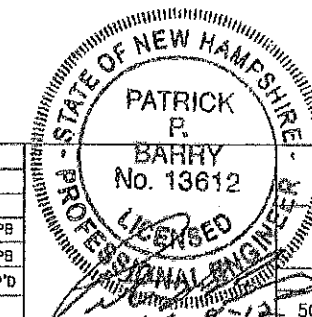

AT&T MOBILITY
FRAMINGHAM, MA 01701

TITLE SHEET

DEWBERRY NO.	DRAWING NUMBER	REV
50019239/50044393	T01	1

GENERAL NOTES:

- FOR THE PURPOSE OF CONSTRUCTION DRAWING, THE FOLLOWING DEFINITIONS SHALL APPLY:
PROJECT MANAGEMENT - SA
CONTRACTOR - GENERAL CONTRACTOR (CONSTRUCTION)
OWNER - AT&T MOBILITY
OEM - ORIGINAL EQUIPMENT MANUFACTURER
- PRIOR TO THE SUBMISSION OF BIDS, THE BIDDING CONTRACTOR SHALL VISIT THE CELL SITE TO FAMILIARIZE WITH THE EXISTING CONDITIONS AND TO CONFIRM THAT THE WORK CAN BE ACCOMPLISHED AS SHOWN ON THE CONSTRUCTION DRAWINGS. ANY DISCREPANCY FOUND SHALL BE BROUGHT TO THE ATTENTION OF PROJECT MANAGEMENT.
- ALL MATERIALS FURNISHED AND INSTALLED SHALL BE IN STRICT ACCORDANCE WITH ALL APPLICABLE CODES, REGULATIONS, AND ORDINANCES. CONTRACTOR SHALL ISSUE ALL APPROPRIATE NOTICES AND COMPLY WITH ALL LAWS, ORDINANCES, RULES, REGULATIONS, AND LAWFUL ORDERS OF ANY PUBLIC AUTHORITY REGARDING THE PERFORMANCE OF THE WORK.
- ALL WORK CARRIED OUT SHALL COMPLY WITH ALL APPLICABLE MUNICIPAL AND UTILITY COMPANY SPECIFICATIONS AND LOCAL JURISDICTIONAL CODES, ORDINANCES AND APPLICABLE REGULATIONS.
- DRAWINGS PROVIDED HERE ARE NOT TO SCALE UNLESS OTHERWISE NOTED AND ARE INTENDED TO SHOW OUTLINE ONLY.
- UNLESS NOTED OTHERWISE, THE WORK SHALL INCLUDE FURNISHING MATERIALS, EQUIPMENT, APPURTENANCES, AND LABOR NECESSARY TO COMPLETE ALL INSTALLATIONS AS INDICATED ON THE DRAWINGS.
- THE CONTRACTOR SHALL INSTALL ALL EQUIPMENT AND MATERIALS IN ACCORDANCE WITH MANUFACTURER'S RECOMMENDATIONS UNLESS SPECIFICALLY STATED OTHERWISE.
- IF THE SPECIFIED EQUIPMENT CANNOT BE INSTALLED AS SHOWN ON THESE DRAWINGS, THE CONTRACTOR SHALL PROPOSE AN ALTERNATIVE INSTALLATION FOR APPROVAL BY PROJECT MANAGEMENT.
- CONTRACTOR SHALL DETERMINE ACTUAL ROUTING OF CONDUIT, POWER AND T1 CABLES, GROUNDING CABLES AS SHOWN ON THE POWER, GROUNDING AND TELCO PLAN DRAWING. CONTRACTOR SHALL UTILIZE EXISTING TRAYS AND/OR SHALL ADD NEW TRAYS AS NECESSARY. CONTRACTOR SHALL CONFIRM THE ACTUAL ROUTING WITH PROJECT MANAGEMENT.
- THE CONTRACTOR SHALL PROTECT EXISTING & PROPOSED IMPROVEMENTS, PAVEMENTS, CURBS, LANDSCAPING AND STRUCTURES. ANY DAMAGED PART SHALL BE REPAIRED AT CONTRACTOR'S EXPENSE TO THE SATISFACTION OF THE OWNER.
- CONTRACTOR SHALL LEGALLY AND PROPERLY DISPOSE OF ALL SCRAP MATERIALS SUCH AS COAXIAL CABLES AND OTHER ITEMS REMOVED FROM THE EXISTING FACILITY. ANTENNAS REMOVED SHALL BE RETURNED TO THE OWNER'S DESIGNATED LOCATION.
- CONTRACTOR SHALL LEAVE PREMISES IN CLEAN CONDITION.
- THE CONTRACTOR SHALL SUPERVISE AND DIRECT THE PROJECT DESCRIBED HEREIN. THE CONTRACTOR SHALL BE SOLELY RESPONSIBLE FOR ALL CONSTRUCTION MEANS, METHODS, TECHNIQUES, SEQUENCES, AND PROCEDURES AND FOR COORDINATING ALL PORTIONS OF THE WORK UNDER THE CONTRACT.
- CONTRACTOR SHALL NOTIFY DEWBERRY 48 HOURS IN ADVANCE OF POURING CONCRETE, OR BACKFILLING TRENCHES, SEALING ROOF AND WALL PENETRATIONS & POST DOWNS, FINISHING NEW WALLS OR FINAL ELECTRICAL CONNECTIONS FOR ENGINEER REVIEW.
- CONTRACTOR SHALL VERIFY ALL EXISTING DIMENSIONS AND CONDITIONS PRIOR TO COMMENCING ANY WORK. ALL DIMENSIONS OF EXISTING CONSTRUCTION SHOWN ON THE DRAWINGS MUST BE VERIFIED. CONTRACTOR SHALL NOTIFY PROJECT MANAGEMENT OF ANY DISCREPANCIES PRIOR TO ORDERING MATERIAL OR PROCEEDING WITH CONSTRUCTION.
- THE EXISTING CELL SITE IS IN FULL COMMERCIAL OPERATION. ANY CONSTRUCTION WORK BY CONTRACTOR SHALL NOT DISRUPT THE EXISTING NORMAL OPERATION. ANY WORK ON EXISTING EQUIPMENT MUST BE COORDINATED WITH CONTRACTOR. ALSO, WORK SHOULD BE SCHEDULED FOR AN APPROPRIATE MAINTENANCE WINDOW USUALLY IN LOW TRAFFIC PERIODS AFTER MIDNIGHT.
- SINCE THE CELL SITE IS ACTIVE, ALL SAFETY PRECAUTIONS MUST BE TAKEN WHEN WORKING AROUND HIGH LEVELS OF ELECTROMAGNETIC RADIATION. EQUIPMENT SHOULD BE SHUTDOWN PRIOR TO PERFORMING ANY WORK THAT COULD EXPOSE THE WORKERS TO DANGER. PERSONAL RF EXPOSURE MONITORS ARE ADVISED TO BE WORN TO ALERT OF ANY DANGEROUS EXPOSURE LEVELS.
- CONTRACTOR SHALL BE RESPONSIBLE FOR SITE SAFETY INCLUDING COMPLIANCE WITH ALL APPLICABLE OSHA STANDARDS AND RECOMMENDATIONS AND SHALL PROVIDE ALL NECESSARY SAFETY DEVICES INCLUDING PPE AND PPM AND CONSTRUCTION DEVICES SUCH AS WELDING AND FIRE PREVENTION, TEMPORARY SHORING, SCAFFOLDING, TRENCH SOXES/SLOPING, BARRIERS, ETC.

SITE WORK GENERAL NOTES:

- THE CONTRACTOR SHALL CONTACT UTILITY LOCATING SERVICES PRIOR TO THE START OF CONSTRUCTION.
- ALL EXISTING ACTIVE SEWER, WATER, GAS, ELECTRIC, AND OTHER UTILITIES WHERE ENCOUNTERED IN THE WORK, SHALL BE PROTECTED AT ALL TIMES, AND WHERE REQUIRED FOR THE PROPER EXECUTION OF THE WORK, SHALL BE RELOCATED AS DIRECTED BY CONTRACTOR. EXTREME CAUTION SHOULD BE USED BY THE CONTRACTOR WHEN EXCAVATING OR DRILLING PIERS AROUND OR NEAR UTILITIES. CONTRACTOR SHALL PROVIDE SAFETY TRAINING FOR THE WORKING CREW. THIS WILL INCLUDE BUT NOT BE LIMITED TO:
A) FALL PROTECTION
B) CONFINED SPACE
C) ELECTRICAL SAFETY
D) TRENCHING & EXCAVATION.
- ALL SITE WORK SHALL BE AS INDICATED ON THE DRAWINGS AND PROJECT SPECIFICATIONS.
- IF NECESSARY, RUBBISH, STUMPS, DEBRIS, STICKS, STONES, TOP SOIL AND OTHER REFUSE SHALL BE REMOVED FROM THE SITE AND DISPOSED OF LEGALLY.
- ALL EXISTING INACTIVE SEWER, WATER, GAS, ELECTRIC AND OTHER UTILITIES, WHICH INTERFERE WITH THE EXECUTION OF THE WORK, SHALL BE REMOVED AND/OR CAPPED, PLUGGED OR OTHERWISE DISCONTINUED AT POINTS WHICH WILL NOT INTERFERE WITH THE EXECUTION OF THE WORK, SUBJECT TO THE APPROVAL OF CONTRACTOR, OWNER AND/OR LOCAL UTILITIES.
- CONTRACTOR SHALL MINIMIZE DISTURBANCE TO EXISTING SITE DURING CONSTRUCTION.
- THE CONTRACTOR SHALL PROVIDE SITE SIGNAGE IN ACCORDANCE WITH THE AT&T SPECIFICATION FOR SITE SIGNAGE.
- THE SITE SHALL BE GRADED TO CAUSE SURFACE WATER TO FLOW AWAY FROM THE TRANSMISSION EQUIPMENT AND TOWER AREAS.
- NO FILL OR EMBANKMENT MATERIAL SHALL BE PLACED ON FROZEN GROUND. FROZEN MATERIALS, SNOW OR ICE SHALL NOT BE PLACED IN ANY FILL OR EMBANKMENT.
- THE SUB GRADE SHALL BE COMPACTED AND BROUGHT TO A SMOOTH UNIFORM GRADE PRIOR TO FINISHED SURFACE APPLICATION. SEE SOIL COMPACTION NOTES.
- THE AREAS OF THE OWNER'S PROPERTY DISTURBED BY THE WORK AND NOT COVERED BY THE TOWER, EQUIPMENT OR DRIVEWAY, SHALL BE GRADED TO A UNIFORM SLOPE, AND STABILIZED TO PREVENT EROSION.
- EROSION CONTROL MEASURES, IF REQUIRED DURING CONSTRUCTION, SHALL BE IN CONFORMANCE WITH THE LOCAL JURISDICTION'S GUIDELINES FOR EROSION AND SEDIMENT CONTROL.

CONCRETE AND REINFORCING STEEL NOTES:

- ALL CONCRETE WORK SHALL BE IN ACCORDANCE WITH THE ACI 301, ACI 318, ACI 336, ASTM A184, ASTM A185 AND THE DESIGN AND CONSTRUCTION SPECIFICATION FOR CAST-IN-PLACE CONCRETE.
- ALL CONCRETE SHALL HAVE A MINIMUM COMPRESSIVE STRENGTH OF 4000 PSI AT 28 DAYS, UNLESS NOTED OTHERWISE. A HIGHER STRENGTH (4000 PSI) MAY BE USED. ALL CONCRETING WORK SHALL BE DONE IN ACCORDANCE WITH ACI 318 CODE REQUIREMENTS.
- REINFORCING STEEL SHALL CONFORM TO ASTM A 615, GRADE 60, DEFORMED UNLESS NOTED OTHERWISE. WELDED WIRE FABRIC SHALL CONFORM TO ASTM A 185 STEEL WIRE FABRIC UNLESS NOTED OTHERWISE (UNO). SPLICES SHALL BE CLASS "B" AND ALL HOOKS SHALL BE STANDARD, UNO.
- THE FOLLOWING MINIMUM CONCRETE COVER SHALL BE PROVIDED FOR REINFORCING STEEL, UNLESS SHOWN OTHERWISE ON DRAWINGS:
CONCRETE CAST AGAINST EARTH.....3 IN.
CONCRETE EXPOSED TO EARTH OR WEATHER:
#6 AND LARGER2 IN.
#5 AND SMALLER & WWF.....1 1/2 IN.
CONCRETE NOT EXPOSED TO EARTH OR WEATHER OR NOT CAST AGAINST THE GROUND:
SLAB AND WALL3/4 IN.
BEAMS AND COLUMNS.....1 1/2 IN.
- A CHAMFER 3/4" SHALL BE PROVIDED AT ALL EXPOSED EDGES OF CONCRETE, UNO, IN ACCORDANCE WITH ACI 301 SECTION 4.2.4.
- INSTALLATION OF CONCRETE EXPANSION/WEDGE ANCHOR, SHALL BE PER MANUFACTURER'S WRITTEN RECOMMENDED PROCEDURE. THE ANCHOR BOLT, DOWEL OR ROD SHALL CONFORM TO MANUFACTURER'S RECOMMENDATION FOR EMBEDMENT DEPTH OR AS SHOWN ON THE DRAWINGS. NO REBAR SHALL BE CUT WITHOUT PRIOR CONTRACTOR APPROVAL WHEN DRILLING HOLES IN CONCRETE. SPECIAL INSPECTIONS, REQUIRED BY GOVERNING CODES, SHALL BE PERFORMED IN ORDER TO MAINTAIN MANUFACTURER'S MAXIMUM ALLOWABLE LOADS. ALL EXPANSION/WEDGE ANCHORS SHALL BE STAINLESS STEEL OR HOT DIPPED GALVANIZED. EXPANSION BOLTS SHALL BE PROVIDED BY RAMSET/REDHEAD OR APPROVED EQUAL.
- CONCRETE CYLINDER TEST IS NOT REQUIRED FOR SLAB ON GRADE WHEN CONCRETE IS LESS THAN 50 CUBIC YARDS (IBC 1905.8.2.3) IN THAT EVENT THE FOLLOWING RECORDS SHALL BE PROVIDED BY THE CONCRETE SUPPLIER:
(A) RESULTS OF CONCRETE CYLINDER TESTS PERFORMED AT THE SUPPLIER'S PLANT.
(B) CERTIFICATION OF MINIMUM COMPRESSIVE STRENGTH FOR THE CONCRETE GRADE SUPPLIED.
FOR GREATER THAN 50 CUBIC YARDS THE GC SHALL PERFORM THE CONCRETE CYLINDER TEST.
- AS AN ALTERNATIVE TO ITEM 7, TEST CYLINDERS SHALL BE TAKEN INITIALLY AND THEREAFTER FOR EVERY 50 YARDS OF CONCRETE FROM EACH DIFFERENT BATCH PLANT.
- EQUIPMENT SHALL NOT BE PLACED ON NEW PADS FOR SEVEN DAYS AFTER PAD IS POURED, UNLESS IT IS VERIFIED BY CYLINDER TESTS THAT COMPRESSIVE STRENGTH HAS BEEN ATTAINED.

STRUCTURAL STEEL NOTES:

- ALL STEEL WORK SHALL BE PAINTED OR GALVANIZED IN ACCORDANCE WITH THE DRAWINGS UNLESS NOTED OTHERWISE. STRUCTURAL STEEL SHALL BE ASTM-A-36 UNLESS OTHERWISE NOTED ON THE SITE SPECIFIC DRAWINGS. STEEL DESIGN, INSTALLATION AND BOLTING SHALL BE PERFORMED IN ACCORDANCE WITH THE AMERICAN INSTITUTE OF STEEL CONSTRUCTION (AISC) "MANUAL OF STEEL CONSTRUCTION".
- ALL WELDING SHALL BE PERFORMED USING E70XX ELECTRODES AND WELDING SHALL CONFORM TO AISC. WHERE FILLET WELD SIZES ARE NOT SHOWN, PROVIDE THE MINIMUM SIZE PER TABLE J2.4 IN THE AISC "MANUAL OF STEEL CONSTRUCTION". PAINTED SURFACES SHALL BE TOUCHED UP.
- BOLTED CONNECTIONS SHALL BE ASTM A325 BEARING TYPE (5/4"Ø) CONNECTIONS AND SHALL HAVE MINIMUM OF TWO BOLTS UNLESS NOTED OTHERWISE.
- NON-STRUCTURAL CONNECTIONS FOR STEEL GRATING MAY USE 5/8" DIA. ASTM A 307 BOLTS UNLESS NOTED OTHERWISE.
- INSTALLATION OF CONCRETE EXPANSION/WEDGE ANCHOR, SHALL BE PER MANUFACTURER'S WRITTEN RECOMMENDED PROCEDURE. THE ANCHOR BOLT, DOWEL OR ROD SHALL CONFORM TO MANUFACTURER'S RECOMMENDATION FOR EMBEDMENT DEPTH OR AS SHOWN ON THE DRAWINGS. NO REBAR SHALL BE CUT WITHOUT PRIOR CONTRACTOR APPROVAL WHEN DRILLING HOLES IN CONCRETE. SPECIAL INSPECTIONS, REQUIRED BY GOVERNING CODES, SHALL BE PERFORMED IN ORDER TO MAINTAIN MANUFACTURER'S MAXIMUM ALLOWABLE LOADS. ALL EXPANSION/WEDGE ANCHORS SHALL BE STAINLESS STEEL OR HOT DIPPED GALVANIZED. EXPANSION BOLTS SHALL BE PROVIDED BY RAMSET/REDHEAD OR APPROVED EQUAL.
- CONTRACTOR SHALL SUBMIT SHOP DRAWINGS FOR ENGINEER REVIEW & APPROVAL ON PROJECTS REQUIRING STRUCTURAL STEEL.
- ALL STRUCTURAL STEEL WORK SHALL BE DONE IN ACCORDANCE WITH AISC SPECIFICATIONS.

SOIL COMPACTION NOTES FOR SLAB ON GRADE:

- EXCAVATE AS REQUIRED TO REMOVE VEGETATION & TOPSOIL. EXPOSE UNDISTURBED NATURAL SUBGRADE AND PLACE CRUSHED STONE AS REQUIRED.
- COMPACTION CERTIFICATION: AN INSPECTION AND WRITTEN CERTIFICATION BY A QUALIFIED GEOTECHNICAL TECHNICIAN OR ENGINEER IS ACCEPTABLE.
- AS AN ALTERNATIVE TO INSPECTION AND WRITTEN CERTIFICATION, THE "UNDISTURBED SOIL" BASE SHALL BE COMPACTED WITH "COMPACTION EQUIPMENT", LISTED BELOW, TO AT LEAST 90% MODIFIED PROCTOR MAXIMUM DENSITY PER ASTM D 1557 METHOD C.
- COMPACTED SUBBASE SHALL BE UNIFORM & LEVELED. PROVIDE 8" MINIMUM CRUSHED STONE OR GRAVEL COMPACTED IN 3" LIFTS ABOVE COMPACTED SOIL. GRAVEL SHALL BE NATURAL OR CRUSHED WITH 100% PASSING 1" SIEVE.
- AS AN ALTERNATIVE TO ITEMS 2 AND 3 PROOFROLL THE SUBGRADE SOILS WITH 5 PASSES OF A MEDIUM SIZED VIBRATORY PLATE COMPACTOR (SUCH AS BOMAG BPR 30/38) OR HAND-OPERATED SINGLE DRUM VIBRATORY ROLLER (SUCH AS BOMAG BW 55E). ANY SOFT AREAS THAT ARE ENCOUNTERED SHOULD BE REMOVED AND REPLACED WITH A WELL-GRADED GRANULAR FILL, AND COMPACTED AS STATED ABOVE.

COMPACTION EQUIPMENT:

- HAND OPERATED DOUBLE DRUM, VIBRATORY ROLLER, VIBRATORY PLATE COMPACTOR OR JUMPING JACK COMPACTOR.

CONSTRUCTION NOTES:

- FIELD VERIFICATION:
CONTRACTOR SHALL FIELD VERIFY SCOPE OF WORK, AT&T ANTENNA PLATFORM LOCATION AND ANTENNAS TO BE REPLACED.
- COORDINATION OF WORK:
CONTRACTOR SHALL COORDINATE RF WORK AND PROCEDURES WITH PROJECT MANAGEMENT.
- CABLE LADDER RACK:
CONTRACTOR SHALL FURNISH AND INSTALL CABLE LADDER RACK, CABLE TRAY, AND CONDUIT AS REQUIRED TO SUPPORT CABLES TO THE NEW BTS LOCATION.

ELECTRICAL INSTALLATION NOTES:

- ALL ELECTRICAL WORK SHALL BE PERFORMED IN ACCORDANCE WITH THE PROJECT SPECIFICATIONS, NEC AND ALL APPLICABLE LOCAL CODES.
- CONTRACTOR SHALL MODIFY EXISTING CABLE TRAY SYSTEM AS REQUIRED TO SUPPORT RF AND TRANSPORT CABLE TO THE NEW BTS EQUIPMENT. CONTRACTOR SHALL SUBMIT MODIFICATIONS TO PROJECT MANAGEMENT FOR APPROVAL.
- CONDUIT ROUTINGS ARE SCHEMATIC. CONTRACTOR SHALL INSTALL CONDUITS SO THAT ACCESS TO EQUIPMENT IS NOT BLOCKED.
- WIRING, RACEWAY AND SUPPORT METHODS AND MATERIALS SHALL COMPLY WITH THE REQUIREMENTS OF THE NEC AND TELCORDIA.
- ALL CIRCUITS SHALL BE SEGREGATED AND MAINTAIN MINIMUM CABLE SEPARATION AS REQUIRED BY THE NEC AND TELCORDIA.
- CABLES SHALL NOT BE ROUTED THROUGH LADDER-STYLE CABLE TRAY RUNGS.
- EACH END OF EVERY POWER, POWER PHASE CONDUCTOR (I.E., HOTS), GROUNDING, AND T1 CONDUCTOR AND CABLE SHALL BE LABELED WITH COLOR-CODED INSULATION OR ELECTRICAL TAPE (3M BRAND, 1/2 INCH PLASTIC ELECTRICAL TAPE WITH UV PROTECTION, OR EQUAL). THE IDENTIFICATION METHOD SHALL CONFORM WITH NEC & OSHA, AND MATCH EXISTING INSTALLATION REQUIREMENTS.
- ALL ELECTRICAL COMPONENTS SHALL BE CLEARLY LABELED WITH ENGRAVED LAMACOID PLASTIC LABELS. ALL EQUIPMENT SHALL BE LABELED WITH THEIR VOLTAGE RATING, PHASE CONFIGURATION, WIRE CONFIGURATION, POWER OR AMPACITY RATING, AND BRANCH CIRCUIT ID NUMBERS (I.E., PANELBOARD AND CIRCUIT ID'S).
- PANELBOARDS (ID NUMBERS) AND INTERNAL CIRCUIT BREAKERS (CIRCUIT ID NUMBERS) SHALL BE CLEARLY LABELED WITH ENGRAVED LAMACOID PLASTIC LABELS.
- ALL TIE WRAPS SHALL BE CUT FLUSH WITH APPROVED CUTTING TOOL TO REMOVE SHARP EDGES.
- POWER, CONTROL, AND EQUIPMENT GROUND WIRING IN TUBING OR CONDUIT SHALL BE SINGLE CONDUCTOR (SIZE 14 AWG OR LARGER), BODY, OIL RESISTANT THHN OR THWN-2, CLASS B STRANDED COPPER CABLE RATED FOR 90 °C (WET AND DRY) OPERATION; LISTED OR LABELED FOR THE LOCATION AND RACEWAY SYSTEM USED, UNLESS OTHERWISE SPECIFIED.
- POWER PHASE CONDUCTORS (I.E., HOTS) SHALL BE LABELED WITH COLOR-CODED INSULATION OR ELECTRICAL TAPE (3M BRAND, 1/2 INCH PLASTIC ELECTRICAL TAPE WITH UV PROTECTION, OR EQUAL.) PHASE CONDUCTOR COLOR CODES SHALL CONFORM WITH THE NEC & OSHA AND MATCH EXISTING INSTALLATION REQUIREMENTS.
- SUPPLEMENTAL EQUIPMENT GROUND WIRING LOCATED INDOORS SHALL BE SINGLE CONDUCTOR (SIZE 6 AWG OR LARGER), BODY, OIL RESISTANT THHN OR THWN-2 GREEN INSULATION, CLASS B STRANDED COPPER CABLE RATED FOR 90°C (WET AND DRY) OPERATION; LISTED OR LABELED FOR THE LOCATION AND RACEWAY SYSTEM USED, UNLESS OTHERWISE SPECIFIED.
- SUPPLEMENTAL EQUIPMENT GROUND WIRING LOCATED OUTDOORS, OR BELOW GRADE, SHALL BE SINGLE CONDUCTOR #2 AWG SOLID TINNED COPPER CABLE, UNLESS OTHERWISE SPECIFIED.
- POWER AND CONTROL WIRING, NOT IN TUBING OR CONDUIT, SHALL BE MULTI-CONDUCTOR, TYPE TC CABLE (SIZE 14 AWG OR LARGER), BODY, OIL RESISTANT THHN OR THWN-2, CLASS B STRANDED COPPER CABLE RATED FOR 90°C (WET AND DRY) OPERATION; WITH OUTER JACKET; LISTED OR LABELED FOR THE LOCATION USED, UNLESS OTHERWISE SPECIFIED.
- ALL POWER AND POWER GROUNDING CONNECTIONS SHALL BE CRIMP-STYLE, COMPRESSION WIRE LUGS AND WRENUTS BY THOMAS AND BETTS (OR EQUAL). LUGS AND WRENUTS SHALL BE RATED FOR OPERATION AT NO LESS THAN 75°C (90°C IF AVAILABLE).
- RACEWAY AND CABLE TRAY SHALL BE LISTED OR LABELED FOR ELECTRICAL USE IN ACCORDANCE WITH NEMA, UL, ANSI/IEEE, AND NEC.
- NEW RACEWAY OR CABLE TRAY WILL MATCH THE EXISTING INSTALLATION WHERE POSSIBLE.
- ELECTRICAL METALLIC TUBING (EMT) OR RIGID NONMETALLIC CONDUIT (I.E., RIGID PVC SCHEDULE 40, OR RIGID PVC SCHEDULE 80 FOR LOCATIONS SUBJECT TO PHYSICAL DAMAGE) SHALL BE USED FOR EXPOSED INDOOR LOCATIONS.
- ELECTRICAL METALLIC TUBING (EMT), ELECTRICAL NONMETALLIC TUBING (ENT), OR RIGID NONMETALLIC CONDUIT (RIGID PVC, SCHEDULE 40) SHALL BE USED FOR CONCEALED INDOOR LOCATIONS.
- GALVANIZED STEEL INTERMEDIATE METALLIC CONDUIT (IMC) SHALL BE USED FOR OUTDOOR LOCATIONS ABOVE GRADE.
- RIGID NONMETALLIC CONDUIT (I.E., RIGID PVC SCHEDULE 40 OR RIGID PVC SCHEDULE 80) SHALL BE USED UNDERGROUND; DIRECT BURIED, IN AREAS OF OCCASIONAL LIGHT VEHICLE TRAFFIC OR ENCASED IN REINFORCED CONCRETE IN AREAS OF HEAVY VEHICLE TRAFFIC.
- LIQUID-TIGHT FLEXIBLE METALLIC CONDUIT (LIQUID-TITE FLEX) SHALL BE USED INDOORS AND OUTDOORS, WHERE VIBRATION OCCURS OR FLEXIBILITY IS NEEDED.
- CONDUIT AND TUBING FITTINGS SHALL BE THREADED OR COMPRESSION-TYPE AND APPROVED FOR THE LOCATION USED. SETSCREW FITTINGS ARE NOT ACCEPTABLE.
- CABINETS, BOXES, AND WIREWAYS SHALL BE LISTED OR LABELED FOR ELECTRICAL USE IN ACCORDANCE WITH NEMA, UL, ANSI/IEEE, AND NEC.
- CABINETS, BOXES, AND WIREWAYS TO MATCH THE EXISTING INSTALLATION WHERE POSSIBLE.
- WIREWAYS SHALL BE EPOXY-COATED (GRAY) AND INCLUDE A HINGED COVER, DESIGNED TO SWING OPEN DOWNWARD; SHALL BE PANOUT TYPE E (OR EQUAL); AND RATED NEMA 1 (OR BETTER) INDOORS, OR NEMA 3R (OR BETTER) OUTDOORS.
- EQUIPMENT CABINETS, TERMINAL BOXES, JUNCTION BOXES, AND PULL BOXES SHALL BE GALVANIZED OR EPOXY-COATED SHEET STEEL, SHALL MEET OR EXCEED UL 50, AND RATED NEMA 1 (OR BETTER) INDOORS, OR NEMA 3R (OR BETTER) OUTDOORS.
- METAL RECEPTACLE, SWITCH, AND DEVICE BOXES SHALL BE GALVANIZED, EPOXY-COATED, OR NON-CORRODING; SHALL MEET OR EXCEED UL 514A AND NEMA OS 1; AND RATED NEMA 1 (OR BETTER) INDOORS, OR WEATHER PROTECTED (WP OR BETTER) OUTDOORS.
- NONMETALLIC RECEPTACLE, SWITCH, AND DEVICE BOXES SHALL MEET OR EXCEED NEMA OS 2; AND RATED NEMA 1 (OR BETTER) INDOORS, OR WEATHER PROTECTED (WP OR BETTER) OUTDOORS.
- THE CONTRACTOR SHALL NOTIFY AND OBTAIN NECESSARY AUTHORIZATION FROM PROJECT MANAGEMENT BEFORE COMMENCING WORK ON THE AC POWER DISTRIBUTION PANELS.
- THE CONTRACTOR SHALL PROVIDE NECESSARY TRAINING ON THE BREAKERS, CABLES AND DISTRIBUTION PANELS IN ACCORDANCE WITH THE APPLICABLE CODES AND STANDARDS TO SAFEGUARD AGAINST LIFE AND PROPERTY.



Dewberry
Dewberry Engineers Inc.
280 SUMMER ST.
10TH FLOOR
BOSTON, MA 02210
PHONE: 617.895.3400
FAX: 617.895.3310



SAI
communications
22 KEESWAYDIN DRIVE
SALEM, NH 03079

AWE-EXETER MILL
SITE NO. NH2113
BRIDGE STREET
EXETER, NH 03833



at&t
Mobility
550 COCHITUATE ROAD
SUITES 13 & 14
FRAMINGHAM, MA 01701

1	11/09/12	FOR CONSTRUCTION	OAS	DAS	PPB
0	07/23/12	FOR REVIEW	OAS	DAS	PPB
NO.	DATE	REVISIONS	BY	CHK	APP'D
SCALE: AS SHOWN		DESIGNED BY: OAS	DRAWN BY: MR		

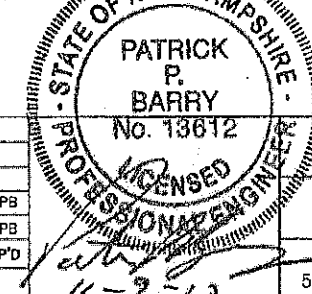

PATRICK P. BARRY
No. 13612
LICENSED PROFESSIONAL ENGINEER
STATE OF NEW HAMPSHIRE

AT&T MOBILITY
FRAMINGHAM, MA 01701

GENERAL NOTES

DEWBERRY NO.	DRAWING NUMBER	REV
50019239/50044393	G01	1

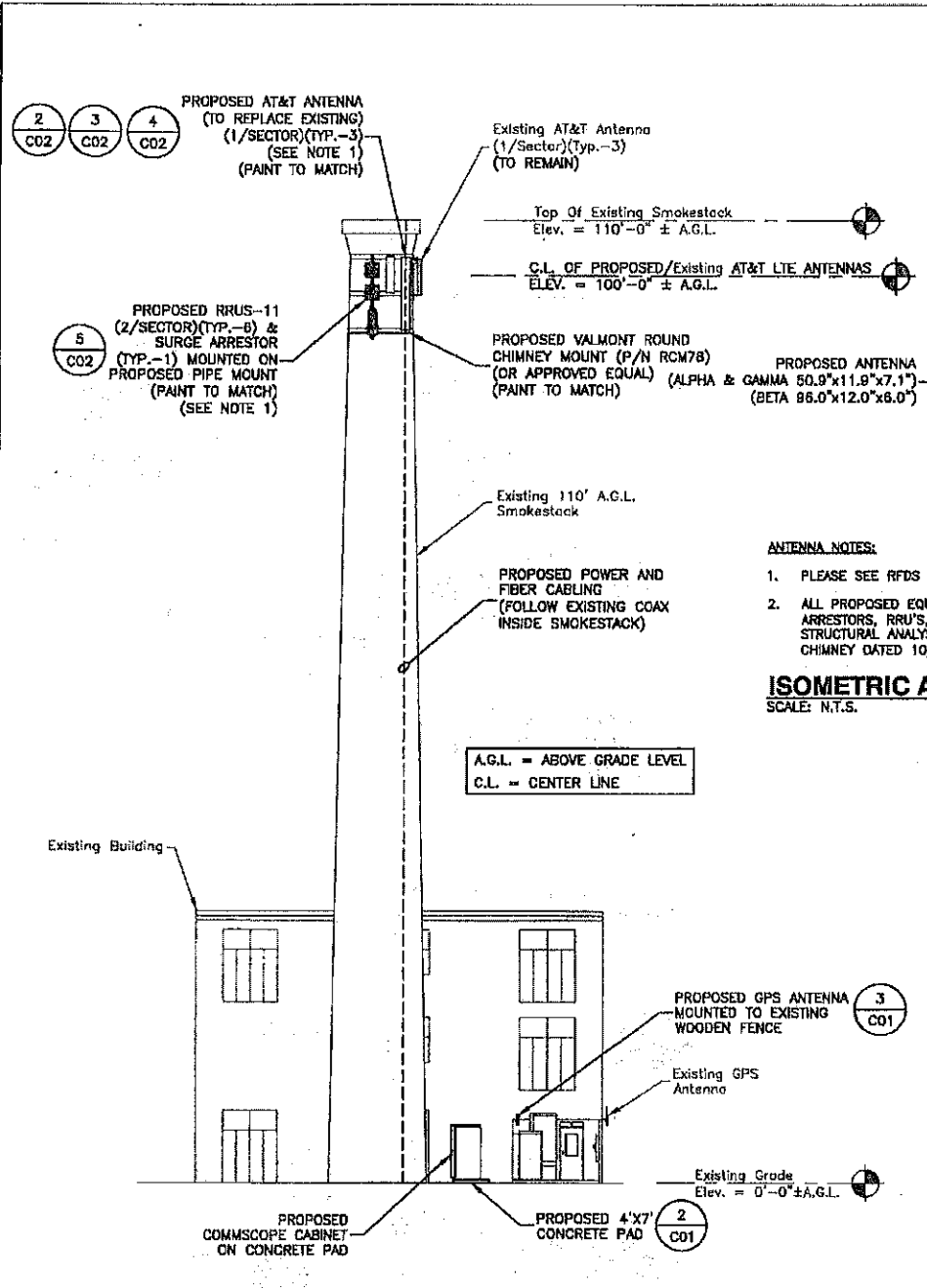

PROPOSED ELEVATION 1
SCALE: 1"=20' FOR 11"x17"
1"=10' FOR 22"x34"
0' 10' 20'

- SMOKESTACK NOTES:**
- ALL PROPOSED EQUIPMENT INCLUDING ANTENNAS, COAX, SURGE ARRESTORS, RRU'S, ETC. SHALL BE IN ACCORDANCE WITH THE STRUCTURAL ANALYSIS REPORT AND INVESTIGATION BY INTERNATIONAL CHIMNEY DATED 10/26/12.
 - PROPOSED GPS ANTENNA TO BE MOUNTED A MINIMUM OF 10' FROM EXISTING GPS ANTENNAS.
 - DEWBERRY WAS NOT PROVIDED WITH OR CONTRACTED TO PERFORM A STRUCTURAL ANALYSIS ON THIS CHIMNEY. CHIMNEY RELATED IMPROVEMENTS ARE NOT TO BE INSTALLED WITHOUT A PASSING STRUCTURAL ANALYSIS. SEE STRUCTURAL NOTE ON SHEET T01.

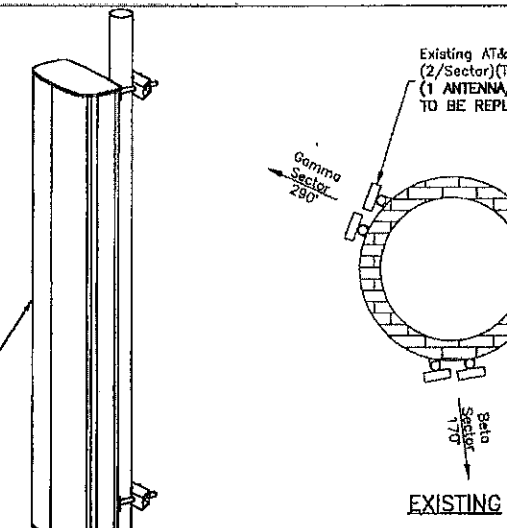

- ANTENNA NOTES:**
- PLEASE SEE RFDS SHEET FOR SPECIFIC ANTENNA MODEL.
 - ALL PROPOSED EQUIPMENT INCLUDING ANTENNAS, COAX, SURGE ARRESTORS, RRU'S, ETC. SHALL BE MOUNTED IN ACCORDANCE WITH THE STRUCTURAL ANALYSIS REPORT AND INVESTIGATION BY INTERNATIONAL CHIMNEY DATED 10/26/12.

ISOMETRIC ANTENNA DETAIL 2
SCALE: N.T.S.

- ANTENNA ORIENTATION NOTES:**
- AZIMUTHS BASED ON TRUE NORTH.
 - ALL PROPOSED EQUIPMENT INCLUDING ANTENNAS, COAX, SURGE ARRESTORS, RRU'S, ETC. SHALL BE MOUNTED IN ACCORDANCE WITH THE STRUCTURAL ANALYSIS REPORT AND INVESTIGATION BY INTERNATIONAL CHIMNEY DATED 10/26/12.

PLATFORM ANTENNA ORIENTATION 3
SCALE: N.T.S.

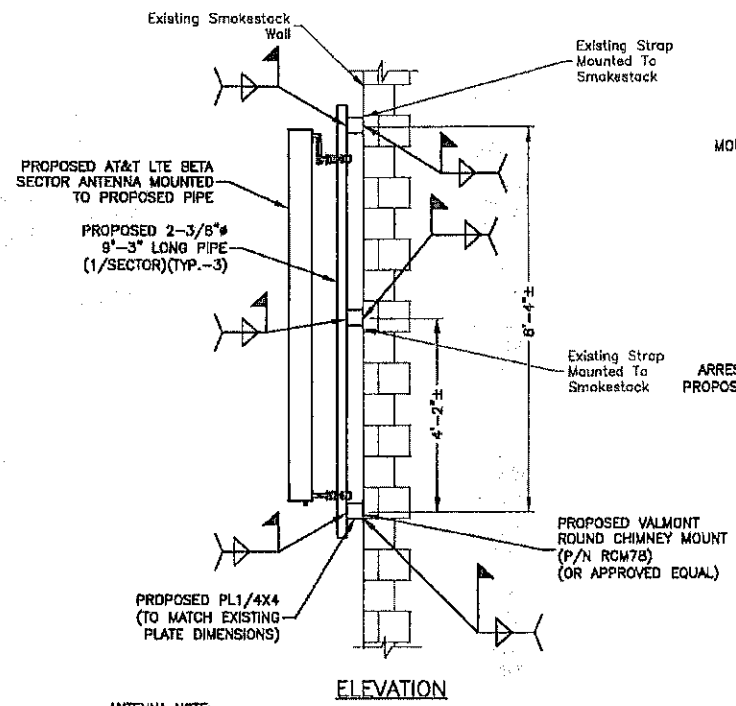

- ANTENNA NOTE:**
- ALL PROPOSED EQUIPMENT INCLUDING ANTENNAS, COAX, SURGE ARRESTORS, RRU'S, ETC. SHALL BE MOUNTED IN ACCORDANCE WITH THE STRUCTURAL ANALYSIS REPORT AND INVESTIGATION BY INTERNATIONAL CHIMNEY DATED 10/26/12 AND MANUFACTURER SPECIFICATIONS.
 - ALL REPAIRS TO THE EXISTING CHIMNEY RECOMMENDED BY INTERNATIONAL CHIMNEY SHALL BE MADE PRIOR TO THE INSTALLATION OF ANY PROPOSED EQUIPMENT.

ANTENNA MOUNTING DETAIL (BETA SECTOR) 4
SCALE: 1"=4' FOR 11"x17"
1"=2' FOR 22"x34"
0' 2' 4'

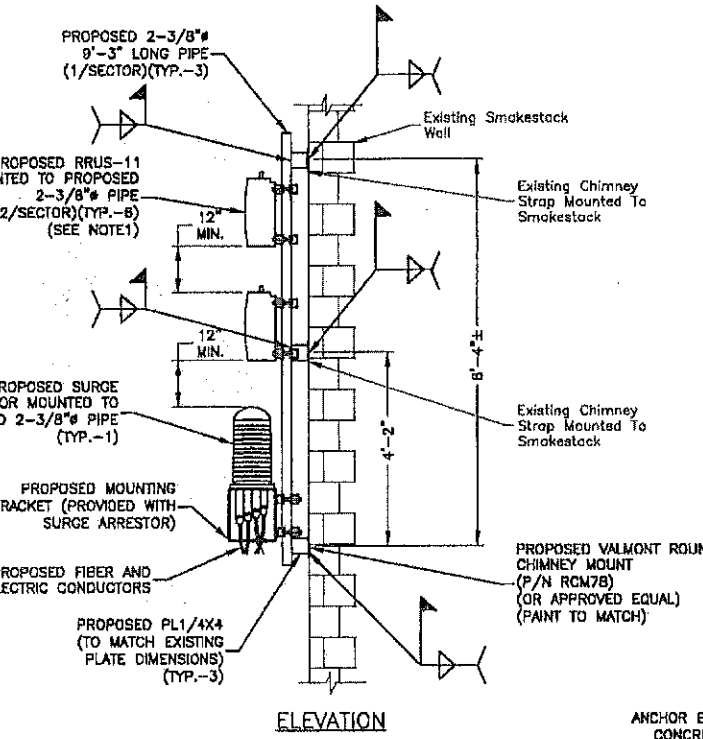

- RRUS-11/SURGE NOTES:**
- ALL PROPOSED EQUIPMENT INCLUDING ANTENNAS, COAX, SURGE ARRESTORS, RRU'S, ETC. SHALL BE MOUNTED IN ACCORDANCE WITH THE STRUCTURAL ANALYSIS REPORT AND INVESTIGATION BY INTERNATIONAL CHIMNEY DATED 10/26/12 AND MANUFACTURER SPECIFICATIONS.
 - ALL REPAIRS TO THE EXISTING CHIMNEY RECOMMENDED BY INTERNATIONAL CHIMNEY SHALL BE MADE PRIOR TO THE INSTALLATION OF ANY PROPOSED EQUIPMENT.

RRUS-11 & SURGE ARRESTOR MOUNTING DETAIL 5
SCALE: 1"=4' FOR 11"x17"
1"=2' FOR 22"x34"
0' 2' 4'

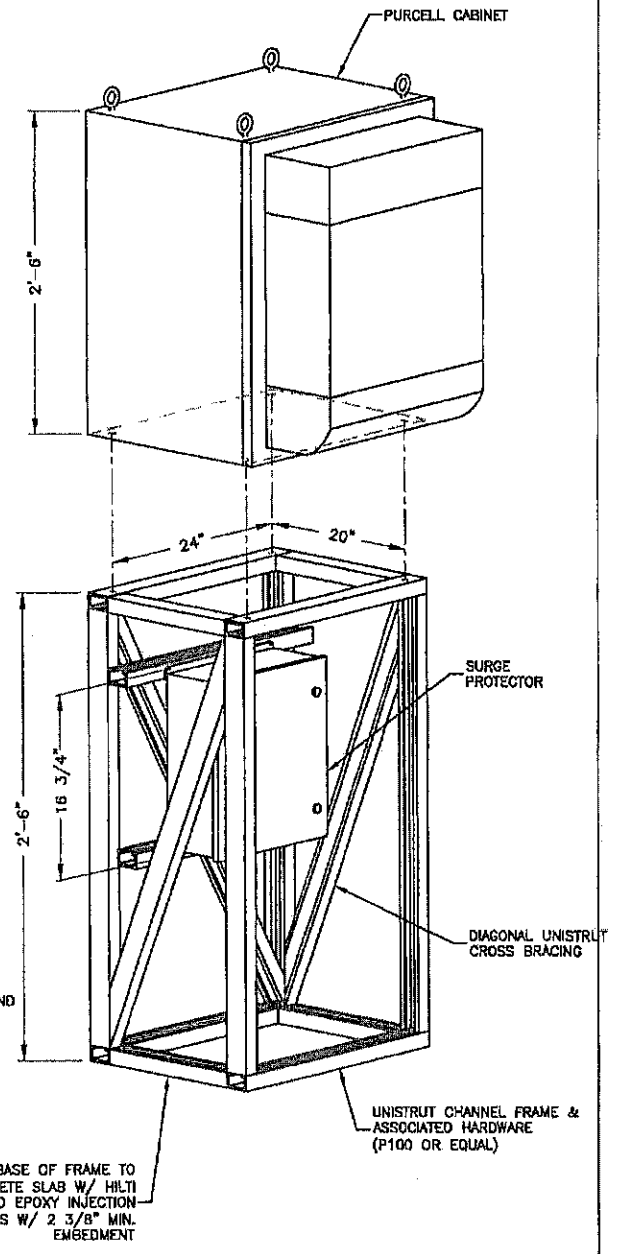

- PURCELL NOTE:**
- ALL MOUNTING HARDWARE TO BE GALVANIZED.

PURCELL LTE FLX12WS 6
SCALE: N.T.S.

Dewberry
Dewberry Engineers Inc.
280 SUMNER ST.
10TH FLOOR
BOSTON, MA 02210
PHONE: 617.695.3400
FAX: 617.695.3310

SAD communications
22 KEEWAYDIN DRIVE
SALEM, NH 03079

**AWE-EXETER MILL
SITE NO. NH2113**
BRIDGE STREET
EXETER, NH 03833

**at&t
Mobility**
550 COCHITUATE ROAD
SUITES 13 & 14
FRAMINGHAM, MA 01701

NO.	DATE	REVISIONS	BY	CHK	APP'D
1	11/09/12	FOR CONSTRUCTION	OAS	DAS	PPB
0	07/23/12	FOR REVIEW	OAS	DAS	PPB

SCALE: AS SHOWN
DESIGNED BY: OAS
DRAWN BY: MR

STATE OF NEW HAMPSHIRE
PATRICK P. BARRY
No. 13612
PROFESSIONAL ENGINEER

**AT&T MOBILITY
FRAMINGHAM, MA 01701**

PROPOSED ELEVATION & CONSTRUCTION DETAILS

DEWBERRY NO.	DRAWING NUMBER	REV
50019239/50044393	CO2	1

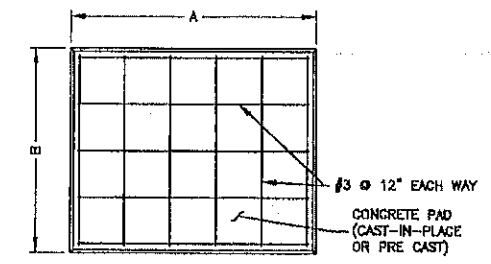
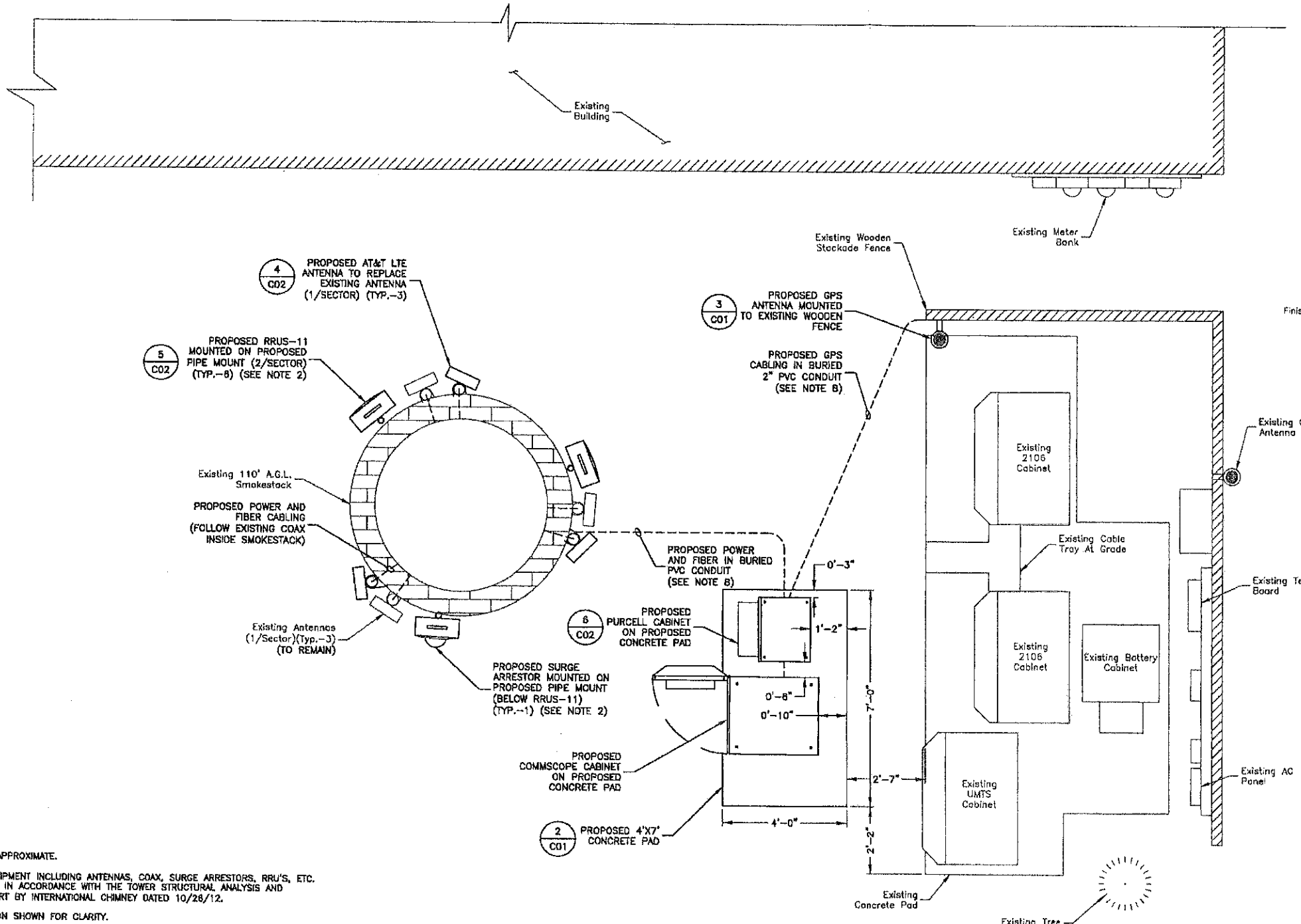
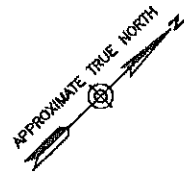

GENERATOR		
A	B	t (THICKNESS)
7'	4'	6"

- OUTDOOR PAD NOTES:**
1. USE GALVANIZED HILT EXPANSION ANCHORS OR APPROVED EQUAL, FOR EQUIPMENT ANCHORAGE.
 2. FOR SIZE AND LOCATION OF ANCHORS AND OTHER REQUIREMENTS, SEE EQUIPMENT VENDOR DRAWINGS.
 3. BEARING STRATA MEDIUM TO DENSE INSET GRANULAR MATERIAL OR COMPACTED GRAVEL FILL, 85% COMPACTION.
 4. FILL SHALL CONSIST OF CLEAN SOIL, NO DELETERIOUS MATERIALS OR ORGANICS TO BE USED.

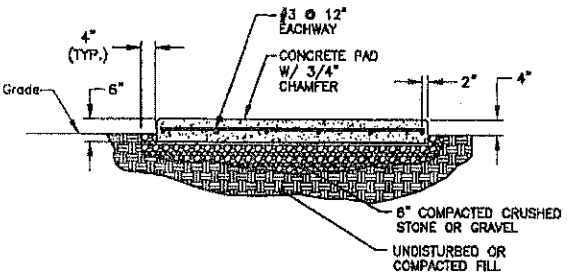

OUTDOOR PAD FOR MINOR EQUIPMENT
SCALE: N.T.S.

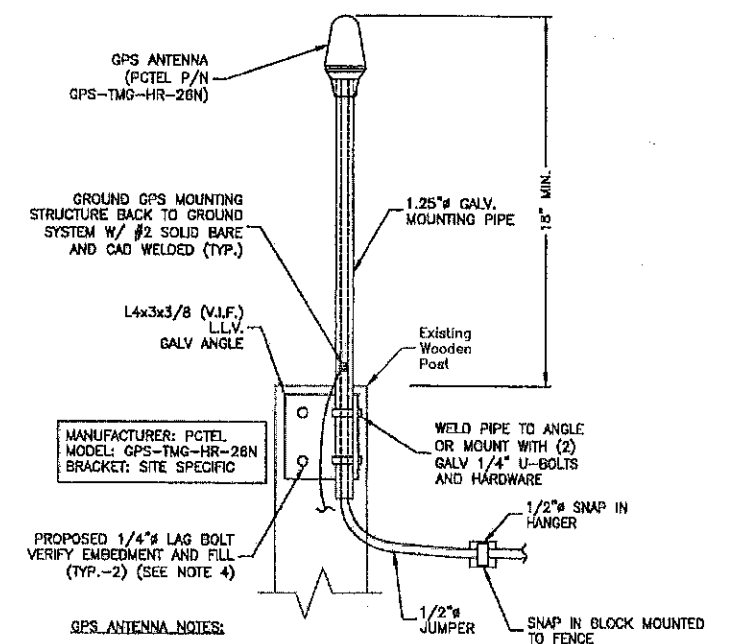

- GPS ANTENNA NOTES:**
1. GROUND ANTENNAS AND MOUNTS PER MANUFACTURER'S RECOMMENDATIONS AND AT&T STANDARDS.
 2. FIELD LOCATE GPS ANTENNA A MINIMUM OF 10' HORIZONTALLY FROM EXISTING GPS ANTENNA WITH AT&T CM APPROVAL.
 3. SEAL ALL WALL PENETRATIONS WITH SILICONE SEALANT.
 4. FIELD VERIFY WOODEN POST CONDITION. INSPECT FOR DETERIORATION OR DAMAGE AND REPLACE AS NEEDED IT.

- NOTES:**
1. NORTH SHOWN AS APPROXIMATE.
 2. ALL PROPOSED EQUIPMENT INCLUDING ANTENNAS, COAX, SURGE ARRESTORS, RRU'S, ETC. SHALL BE MOUNTED IN ACCORDANCE WITH THE TOWER STRUCTURAL ANALYSIS AND INVESTIGATION REPORT BY INTERNATIONAL CHIMNEY DATED 10/26/12.
 3. NOT ALL INFORMATION SHOWN FOR CLARITY.
 4. DRAWING PREPARED PER SITE VISIT PERFORMED BY DEWBERRY ENGINEERS INC. ON 06/21/12.
 5. PROPOSED GPS UNIT TO BE MOUNTED A MINIMUM OF 10' FROM EXISTING GPS UNIT.
 6. ANCHOR EACH PROPOSED CABINET WITH APPROPRIATE HARDWARE, AS SPECIFIED BY THE MANUFACTURER.
 7. INSTALL NEW CONDUIT/CABLING ON EXISTING ICE BRIDGE, CABLE TRAY, OR CABLE RACK. DO NOT CREATE ANY TRIP HAZARDS.
 8. VERIFY LOCATION OF EXISTING UNDERGROUND CONDUITS & GROUNDING PRIOR TO CONSTRUCTION. ADJUST ROUTING AS NECESSARY.
 9. ALL REPAIRS TO THE EXISTING CHIMNEY RECOMMENDED BY INTERNATIONAL CHIMNEY SHALL BE MADE PRIOR TO THE INSTALLATION OF ANY PROPOSED EQUIPMENT.

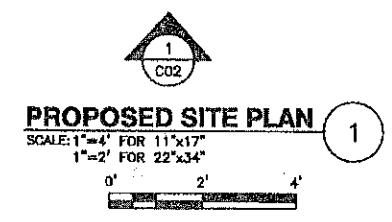

Dewberry
Dewberry Engineers Inc.
280 SUMMER ST.
10TH FLOOR
BOSTON, MA 02210
PHONE: 617.695.3400
FAX: 617.695.3310

SAD communications
22 KEEWAYDIN DRIVE
SALEM, NH 03079

AWE-EXETER MILL
SITE NO. NH2113
BRIDGE STREET
EXETER, NH 03833

at&t
Mobility
550 COCHITUATE ROAD
SUITES 13 & 14
FRAMINGHAM, MA 01701

NO.	DATE	REVISIONS	BY	CHK	APP'D
1	11/09/12	FOR CONSTRUCTION	OAS	DAS	PPB
0	07/23/12	FOR REVIEW	OAS	DAS	PPB

SCALE: AS SHOWN DESIGNED BY: OAS DRAWN BY: MR

GPS ANTENNA MOUNT TO WOODEN POST
SCALE: 1/4\"/>

AT&T MOBILITY
FRAMINGHAM, MA 01701
PROPOSED SITE PLAN & CONSTRUCTION DETAILS
DEWBERRY NO. 30019239/50044393
DRAWING NUMBER C01
REV 1