

Town Of Exeter, New Hampshire

Kingston Road TAP Project

Exeter 40436, X-A004(406)

Issued For Bidding
April 2023



Sheet Number	Sheet Title
1	Cover
2	General Notes
3	Legend and Abbreviations
4-5	Typical Section
6-10	Details
11	Sign Text Layout
12-17	Existing Conditions Plans
18-23	General Plans
24-42	Cross Sections

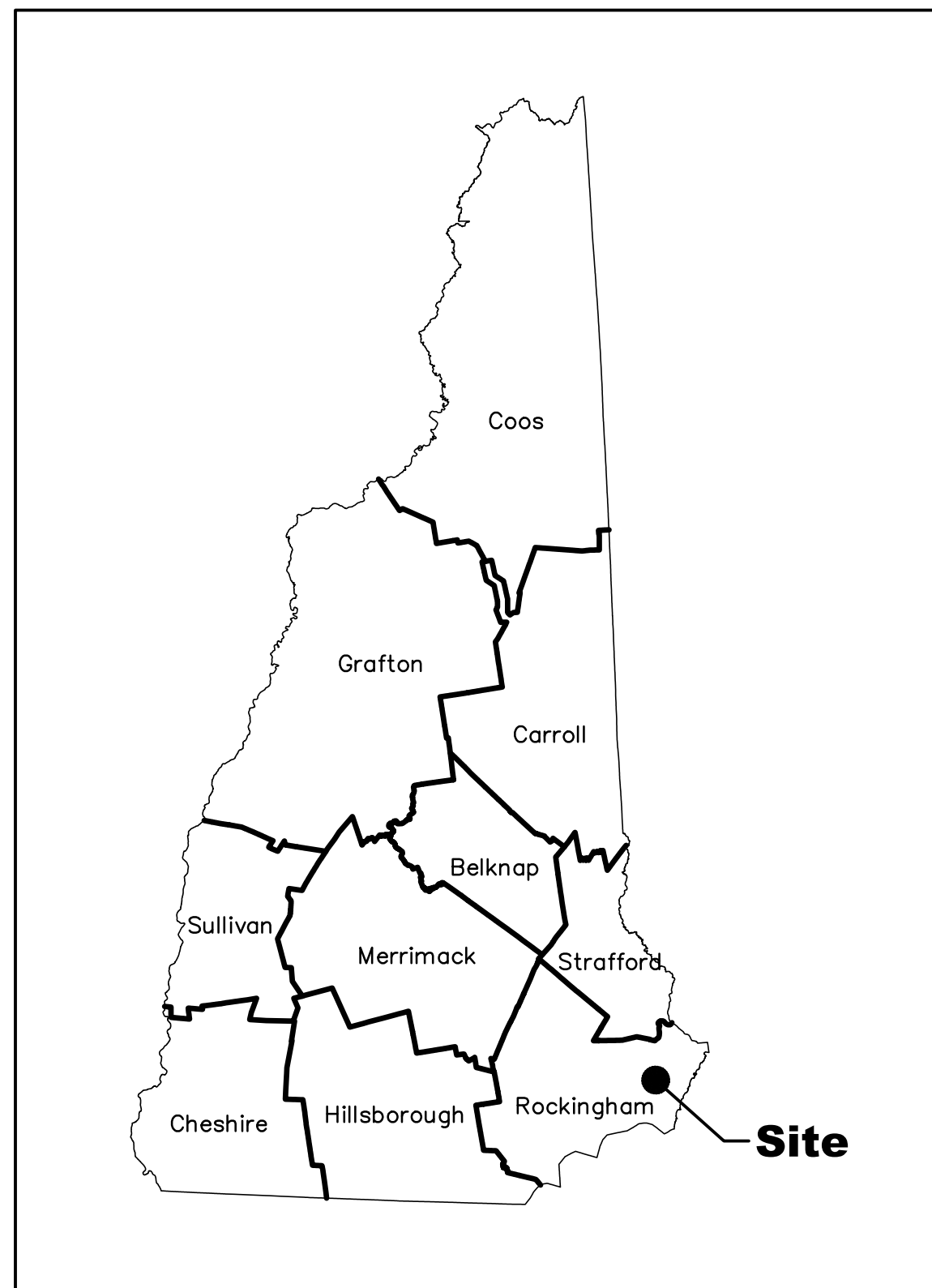

Locus Plan

SITE OVERVIEW
Scale: 1"=250'

Prepared For:
Town of Exeter
Public Works Department
13 Newfields Road
Exeter, NH 03833

Prepared By:

CMA
ENGINEERS

CIVIL/ENVIRONMENTAL/STRUCTURAL
Portsmouth, NH • Manchester, NH • Portland, ME
603/431-6196 • 603/627-0708 • 207/541-4223
cmaengineers.com

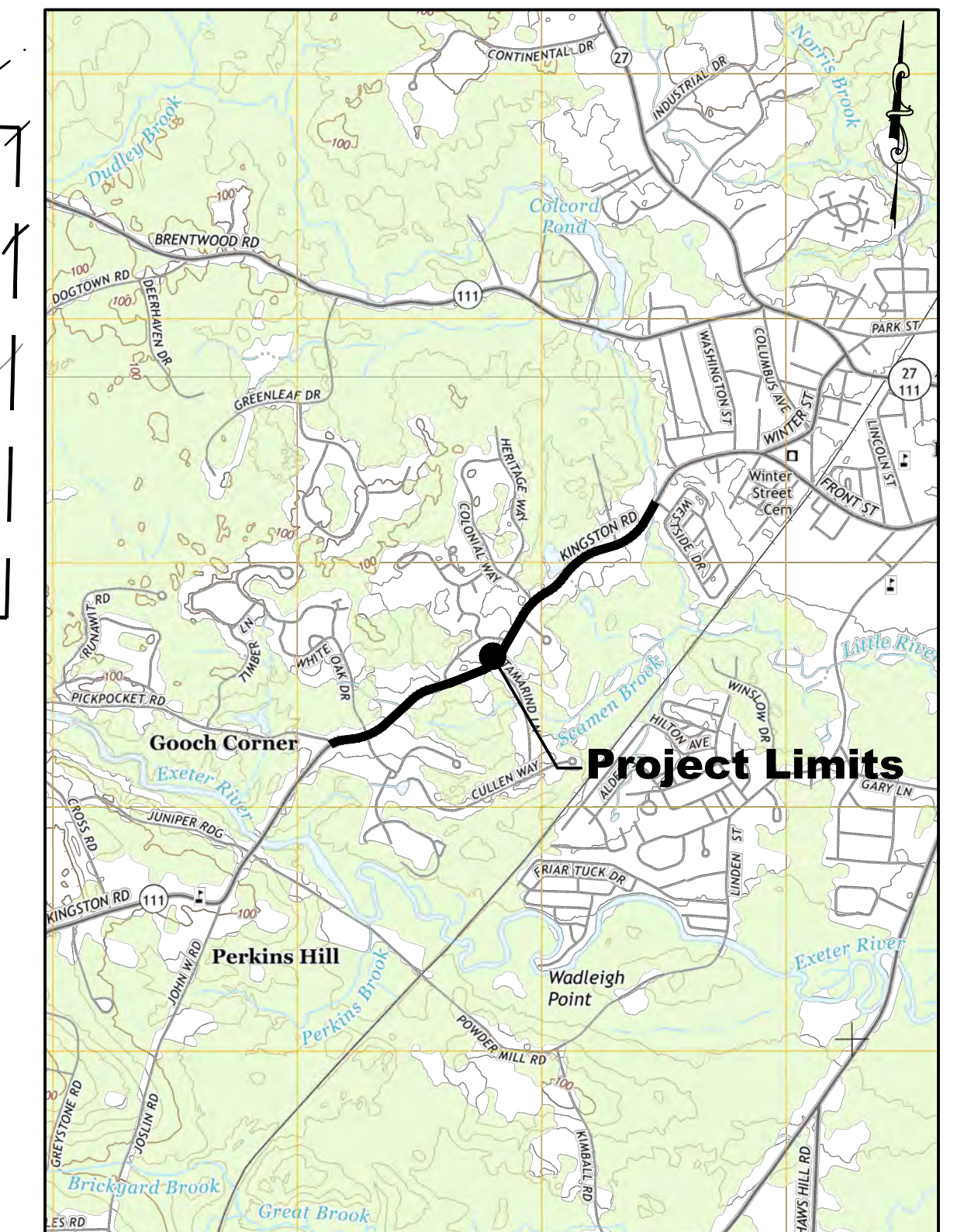
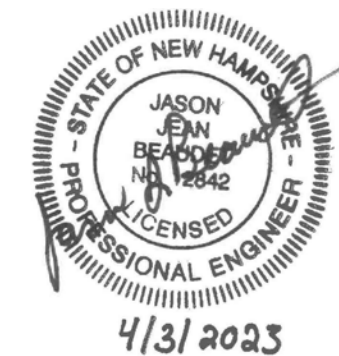

Project Locations

Scale: 1" = 2000'

GENERAL NOTES:

- 1. CONSTRUCTION MATERIALS AND METHODS SHALL CONFORM TO THE REQUIREMENTS NOTED IN THE LATEST EDITION OF THE FOLLOWING STANDARDS AND REGULATIONS...
2. CONTRACTOR SHALL PROTECT PRIVATE PROPERTY AND SHALL TAKE ALL NECESSARY MEASURES AND PRECAUTIONS TO AVOID DAMAGE TO EXISTING TREES, SHRUBS, LAWNS, PLANTINGS, ETC.
3. THE CONTRACTOR SHALL INSPECT THE SITE PRIOR TO CONSTRUCTION TO BE AWARE OF ALL FIELD CONDITIONS AND SHALL VERIFY THE LOCATION OF ALL EXISTING UTILITIES WITH THE APPROPRIATE AGENCIES.
4. THE CONTRACTOR SHALL BE RESPONSIBLE FOR ALL METHODS AND MATERIALS FOR CONSTRUCTION OF THIS PROJECT, INCLUDING COMPLIANCE WITH ALL APPLICABLE OSHA REGULATIONS.
5. THE CONTRACTOR SHALL BE RESPONSIBLE TO REPAIR, TO ORIGINAL CONDITION, ANY AND ALL DAMAGE TO BUILDINGS, PAVEMENT AREAS, EQUIPMENT AND FURNISHINGS CAUSED DURING PERFORMANCE OF WORK COVERED BY THIS CONTRACT.
6. THE CONTRACTOR SHALL KEEP ALL SURFACES UTILIZED BY VEHICLES CONTINUOUSLY FREE OF DEBRIS, WHERE REQUIRED, SURFACES SHALL BE WATERED TO PREVENT THE BLOWING OF DUST.
7. THE CONTRACTOR SHALL EXERCISE CAUTION AND COMPLY WITH ALL APPLICABLE TRAFFIC LAWS AND REGULATIONS IN THE EXECUTION OF WORK.
8. THE CONTRACTOR SHALL BE RESPONSIBLE FOR COMPLIANCE WITH THE NPDES CGP INCLUDING THE PREPARATION AND IMPLEMENTATION OF A STORMWATER POLLUTION PREVENTION PLAN.
9. THE CONTRACTOR IS RESPONSIBLE FOR PROVIDING PEDESTRIAN TRAFFIC CONTROL FOR ANY EXISTING FACILITIES THAT WILL BE DISTURBED/CLOSED DURING CONSTRUCTION.
10. THE CONTRACTOR SHALL PERFORM ALL NECESSARY LAYOUT WORK IN ORDER TO CONSTRUCT ALL ELEMENTS OF THE PROJECT AS SHOWN ON THE PLANS AND SPECIFIED IN THE CONTRACT.
11. THE CONTRACTOR SHALL FIELD VERIFY EXISTING INVERTS LISTED IN DRAINAGE NOTES PRIOR TO ORDERING DRAINAGE STRUCTURES.
12. THE CONTRACTOR SHALL COORDINATE WITH ALL UTILITY OWNERS TO LOCATE EXISTING UNDERGROUND UTILITIES WITHIN THE FOOTPRINT OF THE PROPOSED CLOSED DRAINAGE WORK.
13. THE CONTRACTOR SHALL SET ALL MANHOLE FRAMES AND COVERS AND CATCH BASIN GRATES AND WATER VALVE COVERS TO 1/8" TO 1/4" BELOW FINAL PAVEMENT ELEVATIONS.
14. EXISTING WATER GATES AND VALVES WITHIN THE LIMIT OF WORK SHALL BE ADJUSTED TO MATCH FINAL GRADE, UNLESS OTHERWISE DIRECTED BY THE ENGINEER (SUBSIDIARY).
15. THE FLASHING BEACON ON KINGSTON ROAD IS OWNED BY NHDOT. THE BEACON AND ALL APPURTENANCES SHALL BE SALVAGED TO THE NHDOT.
16. ALL EXISTING SIGNS WITHIN THE PROJECT ARE OWNED BY NHDOT. ANY SIGN/POST THAT IS REMOVED AND NOT RESET SHALL BE SALVAGED TO NHDOT.
17. EXISTING SIDEWALK WILL BE REMOVED UNDER ITEM 203.15 - COMMON EXCAVATION (F) REGARDLESS OF MATERIAL, DEPTH, OR REINFORCEMENT.
18. THE PROJECT REQUIRES THE MANAGEMENT OF LIMITED REUSE SOIL (LRS). LRS REMOVAL LIMITS ARE FROM THE EXISTING EDGE OF PAVEMENT TO THE EDGE OF THE ROW OR SLOPE LIMIT, WHICHEVER IS ENCOUNTERED FIRST.

Table with 3 columns: BEGIN STATION, END STATION, SIDE. Lists disturbed areas to be restored with gravel, including stations like 104+55, 111+58, 119+94, 122+70, 135+00, 137+46, 139+24, 142+29, 143+08, 144+66, 155+16.

EROSION CONTROL NOTES:

- 1. PROJECT IS TO BE MANAGES IN A MANNER THAT MEETS THE REQUIREMENTS AND INTENT OF RSA 430:53 AND CHAPTER AGR 3800 RELATIVE TO INVASIVE SPECIES.
2. PERIMETER CONTROLS SHALL BE INSTALLED PRIOR TO EARTH MOVING OPERATIONS.
3. TEMPORARY WATER DIVERSION MUST BE USED AS NECESSARY UNTIL AREAS ARE STABILIZED.
4. PONDS AND SWALES SHALL BE INSTALLED EARLY ON IN THE CONSTRUCTION SEQUENCE (BEFORE ROUGH GRADING THE SITE).
5. ALL DITCHES AND SWALES SHALL BE STABILIZED PRIOR TO DIRECTING RUNOFF TO THEM.
6. PRIOR TO CONSTRUCTION AND THEREAFTER, EROSION CONTROL MEASURES ARE TO BE IMPLEMENTED AS NECESSARY. THE SMALLEST PRACTICAL AREA OF LAND SHOULD BE EXPOSED AT ANY ONE TIME DURING CONSTRUCTION, BUT IN NO CASE SHALL EXCEED 5 ACRES AT ANY ONE TIME BEFORE DISTURBED AREAS ARE STABILIZED.
7. HAY BALE BARRIERS SHALL BE INSTALLED AND MAINTAINED WHERE NECESSARY. HAY BALE BARRIERS SHALL NOT BE PLACED CLOSER THAN 25- FEET TO DRAIN INLETS AND OUTLETS.
8. ALL DISTURBED AREAS AND SIDE SLOPES WHICH ARE FINISH GRADED WITH NO FURTHER CONSTRUCTION TO TAKE PLACE SHALL BE RAKED, SEEDED AND MULCHED WITHIN 72 HOURS OF ACHIEVING FINAL GRADE.
9. ANY DISTURBED AREAS WHICH ARE TO BE LEFT LONGER THAN TWO WEEKS DURING CONSTRUCTION SHALL BE MACHINE HAY MULCHED AND SEEDED AT THE RATE OF 2 TONS PER ACRE.
10. CONSTRUCTION TRAFFIC SHALL TRAVEL THE ROADBEDS OF EXISTING ROADS.
11. SILT FENCE AND OR SILT SOCK SHALL BE INSTALLED AND MAINTAINED WHERE NECESSARY AND ADDITIONAL SILT FENCE ADDED AS REQUIRED BY THE ENGINEER PRIOR TO ANY ON-SITE GRADING OR DISTURBANCE OF EXISTING SURFACE MATERIAL.
12. AFTER ALL DISTURBED AREAS HAVE BEEN STABILIZED, THE TEMPORARY EROSION CONTROL MEASURES ARE TO BE REMOVED AND ACCUMULATED SEDIMENT DISPOSED OF IN A LOCATION DESIGNATED BY THE OWNER.
13. BALED HAY AND MULCH SHALL BE MOWINGS OF ACCEPTABLE HERBACEOUS GROWTH, FREE FROM NOXIOUS WEEDS OR WOODY STEMS AND SHALL BE DRY.
14. SILT FENCES SHALL BE MINIMUM OF 24 INCHES HIGH WITH THE BOTTOM OF THE CLOTH KEYING INTO THE GROUND. POSTS SHALL BE OF WOOD OR STEEL.
15. THE EROSION CONTROL DEVICES DESCRIBED AND AS SPECIFIED IN THE SPECIFICATIONS REPRESENT THE MINIMUM REQUIRED FOR EROSION CONTROL.
16. SEEDING OF ALL SLOPES AND DISTURBED AREAS TO BE CONDUCTED IN ACCORDANCE WITH SECTION 644 OF THE NHDOT STANDARD SPECIFICATIONS FOR ROAD AND BRIDGE CONSTRUCTION.
17. LIME TO BE IN ACCORDANCE WITH SECTION 642 OF THE NHDOT STANDARD SPECIFICATIONS FOR ROAD AND BRIDGE CONSTRUCTION.
18. FERTILIZER TO BE IN ACCORDANCE WITH SECTION 643 OF THE NHDOT STANDARD SPECIFICATIONS FOR ROAD AND BRIDGE CONSTRUCTION.
19. ALL DRAINAGE SWALES SHALL BE CONSTRUCTED AS EARLY IN THE CONSTRUCTION SEQUENCE AS POSSIBLE. SWALES SHALL BE STABILIZED WITH VEGETATION OR STONE FILL AS SPECIFIED PRIOR TO DIRECTING RUNOFF TO THEM.
20. ALL EROSION CONTROL MEASURES SHALL BE INSPECTED WEEKLY AND AFTER EVERY HALF-INCH OF RAINFALL.
21. WINTER CONSTRUCTION NOTES:
- ALL PROPOSED VEGETATED AREAS WHICH DO NOT EXHIBIT A MINIMUM OF 85% VEGETATIVE GROWTH BY OCTOBER 15TH, OR WHICH ARE DISTURBED AFTER OCTOBER 15TH, SHALL BE STABILIZED BY SEEDING AND INSTALLING EROSION CONTROL BLANKETS ON SLOPES GREATER THAN 3:1, AND SEEDING AND PLACING 3 TO 4 TONS OF MULCH PER ACRE, SECURED WITH ANCHORED NETTING, ELSEWHERE.
- ALL DITCHES OR SWALES WHICH DO NOT EXHIBIT A MINIMUM OF 85% VEGETATIVE GROWTH BY OCTOBER 15TH, OR WHICH ARE DISTURBED AFTER OCTOBER 15TH, SHALL BE STABILIZED TEMPORARILY WITH STONE OR EROSION CONTROL BLANKETS APPROPRIATE FOR THE DESIGN FLOW CONDITIONS;
- AFTER OCTOBER 15TH, INCOMPLETE ROAD OR PARKING SURFACES, WHERE WORK HAS STOPPED FOR THE WINTER SEASON, SHALL BE PROTECTED WITH A MINIMUM OF 3 INCHES OF HOT BITUMINOUS PAVEMENT PER NHDOT 403 ITEMS. PAVEMENT TO BE INCIDENTAL TO OTHER ITEMS. PAVEMENT MIX DESIGN TO BE SUBMITTED FOR REVIEW/APPROVAL BY ENGINEER.

PAVEMENT MARKING NOTES:

- 1. ALL SYMBOLS, WORDS, TRANSVERSE MARKINGS (STOP BARS, CROSSWALK LINES, AND RAILROAD SYMBOLS), LANE LINES AND ALL OTHER MARKING SHALL BE THERMOPLASTIC.
2. PROPOSED 4"SSL(W) EDGLINES ARE NOT SHOWN IN THE PLAN SET FOR CLARITY. CONTRACTOR SHALL REPLACE ALL EDGLINES THAT ARE IMPACTED BY THE PROPOSED SHOULDER RECONSTRUCTION.
3. CROSSWALK MARKINGS SHALL CONFORM TO "PEDESTRIANS CROSSINGS" INCLUDED IN PLAN SET.
4. THE CONTRACTOR SHALL CONTACT JULIE MATHEWS AT THE NHDOT BUREAU OF TRAFFIC AT (603)271-8011 AT LEAST ONE WEEK IN ADVANCE OF FINAL PAVEMENT MARKING OPERATIONS IN ORDER TO REVIEW THE CONTRACTOR'S LAYOUT.
5. REPLACE ANY WORDS/SYMBOLS PER LATEST NHDOT STANDARD PLAN SHEETS.
6. PAVEMENT MARKING SHALL EXTEND BEYOND PROJECT PAVING LIMITS AS INSTRUCTED TO OVERLAP EXISTING MARKINGS DISTURBED BY CONSTRUCTION.

RETROFLECTIVE PAINT PAVEMENT MARKING KEY:

{}SSL()={SIZE IN INCHES} SINGLE SOLID LINE (COLOR)
{}DSL()={SIZE IN INCHES} DOUBLE SOLID LINE (COLOR)
{}SSBL()={SIZE IN INCHES} SINGLE SOLID W/BROKEN LINE (COLOR)
{}SBL()={SIZE IN INCHES} SINGLE BROKEN LINE (COLOR)
{}DBL()={SIZE IN INCHES} DOUBLE BROKEN LINE (COLOR)
(W) = WHITE
(Y) = YELLOW

DRAINAGE NOTES:

- 1. STA 104+18.7, LT 14.7' REPLACE CB FRAME AND GRATE W/ TYPE B, INSTALL POLYLINER GRATE = 74.65
2. STA 111+95.5, RT 27.8' TO STA 112+19.6, RT 27.7' CONSTRUCT 24' X 12" PLASTIC PIPE (SMOOTH INTERIOR) INV. IN = 49.05 INV. OUT = 48.15
3. STA 113+69.2, RT 22.0' TO STA 113+69.5, RT 24.0' CONSTRUCT 2.0' X 21" R.C. PIPE, 2000D INV. IN = 45.04± (EX.) INV. OUT = 45.00
4. STA 129+50.0, RT 19.0' TO STA 129+76.0, RT 33.3' CONSTRUCT 4' CB-B W/ SLAB TOP AND POLYLINER AT +50, RT 19.0' GRADE = 58.40 INV. IN= 56.47 INV. OUT = 56.14
5. STA 129+78.9, RT 25.9' TO STA 129+79.4, RT 30.8' CONSTRUCT 4.9' X 12" PLASTIC PIPE (SMOOTH INTERIOR) WITH HDPE TO CMP CONNECTION INV. IN = 55.98± (EX.) INV. OUT = 55.93
6. STA 134+40.0, RT 19.0' TO STA 134+45.0, RT 31.5' CONSTRUCT 4' CB-B W/ SLAB TOP AND POLYLINER AT +40, RT 19.0' GRADE = 56.17 INV. IN = 53.72 INV. OUT = 53.72
7. STA 150+12.1, LT 16.9' REPLACE CB FRAME AND GRATE W/ TYPE B, INSTALL POLYLINER GRATE = 40.34
8. STA 150+74.3, LT 17.6' TO STA 151+50, LT 17.7' REPLACE CB FRAME AND GRATE W/ TYPE B, INSTALL POLYLINER GRADE = 39.61 EXIST INV IN = 38.26 INV OUT = 38.26
9. STA 151+40.0, RT 19.0' TO STA 151+49.7, RT 28.5' CONSTRUCT DI-D-B W/ POLYLINER AT +40, RT 19.0' (NO SUMP) GRADE = 39.97 INV. IN = 38.14 INV. OUT = 37.81
10. STA 152+05.0, LT 19.9' TO STA 152+04.4, LT 12.9' CONSTRUCT 4' CB-B W/ SLAB TOP, 2' SUMP, AND POLYLINER AT +05.0, LT 19.9' GRADE = 38.81 INV. OUT = 36.70
11. STA 156+15.0, RT 14.0' TO STA 156+55.0, RT 13.4' CONSTRUCT DI-D-B W/ POLYLINER AT +15.0, RT 14.0' CONSTRUCT 36.7' X 12" PLASTIC PIPE (SMOOTH INTERIOR) GRADE = 34.34 INV. OUT = 31.80
12. STA 156+55.0, RT 13.4' TO STA 156+62.0, RT 25.0' CONSTRUCT 4' CB-B W/ ECCENTRIC SLAB TOP AND POLYLINER AT +55.0, RT 14.2' GRADE = 34.40 INV. IN = 31.62 INV. OUT = 31.37
U1. STA 127+95.0, RT 19.0' TO STA 129+50.0, RT 19.0' CONSTRUCT 150.6' X 4" PERF CORR. POLYETHYL PIPE UND. CONSTRUCT FLUSHING BASIN AT 127+95.0, RT 19.0'
U2. STA 129+50.0, RT 19.0' TO STA 129+87.6, RT 19.0' CONSTRUCT 31.7' X 4" PERF CORR. POLYETHYL PIPE UND. CONSTRUCT FLUSHING BASIN AT 129+87.6, RT 19.0'
U3. STA 134+25.0, RT 19.0' TO STA 134+40.0, RT 19.0' CONSTRUCT 12.6' X 4" PERF CORR. POLYETHYL PIPE UND. CONSTRUCT FLUSHING BASIN AT 134+25.0, RT 19.0'
U4. STA 134+40.0, RT 19.0' TO STA 136+55.0, RT 19.0' CONSTRUCT 202.0' X 4" PERF CORR. POLYETHYL PIPE UND. CONSTRUCT FLUSHING BASIN AT 136+55.0, RT 19.0'
U5. STA 148+18.0, RT 19.0' TO STA 151+40.0, RT 19.0' CONSTRUCT 320.6' X 4" PERF CORR. POLYETHYL PIPE UND. CONSTRUCT FLUSHING BASIN AT 148+18.0, RT 19.0'
1. STA 153+50, RT TO STA 153+65, RT - RESETTING TERMINAL UNIT STA 153+65 RT TO STA 154+38 RT - RESETTING GUARDRAIL STA 154+38 RT TO STA 156+29 RT - 31" W-BEAM GUARDRAIL WITH 8" OFFSET BLOCK (B' STEEL POST) STA 156+29 RT - ATTACH TO EXISTING BRIDGE RAIL

Project information including date (April 2023), project no. (1030), file name, scale, and drawing no. (N-1). Includes logos for CMA ENGINEERS and the State of New Hampshire Professional Engineer seal.

ABBREVIATIONS:

Table with 4 columns: Abbreviation, Description, Abbreviation, Description, Abbreviation, Description. Includes entries like AC ASPHALT CONCRETE, APPROX APPROXIMATE, AUX AUXILIARY, etc.

LEGEND:

Table with 3 columns: Symbol, Description, Symbol, Description, Symbol, Description. Includes symbols for BANK FLAG, BORE HOLE, BUSH, BENCHMARK, etc.

Table with 2 columns: JJB, by. Includes date 4/3/2023 and revision 1.

CMA ENGINEERS logo and contact information: CIVIL/ENVIRONMENTAL/STRUCTURAL, Portsmouth, NH, Manchester, NH, Portland, ME.

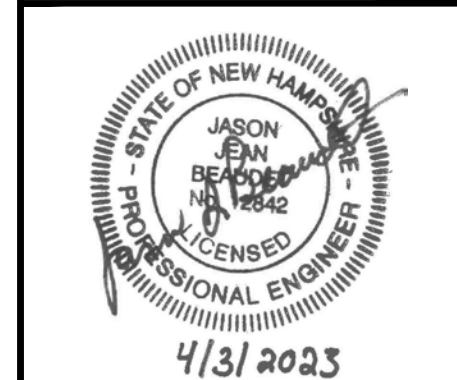
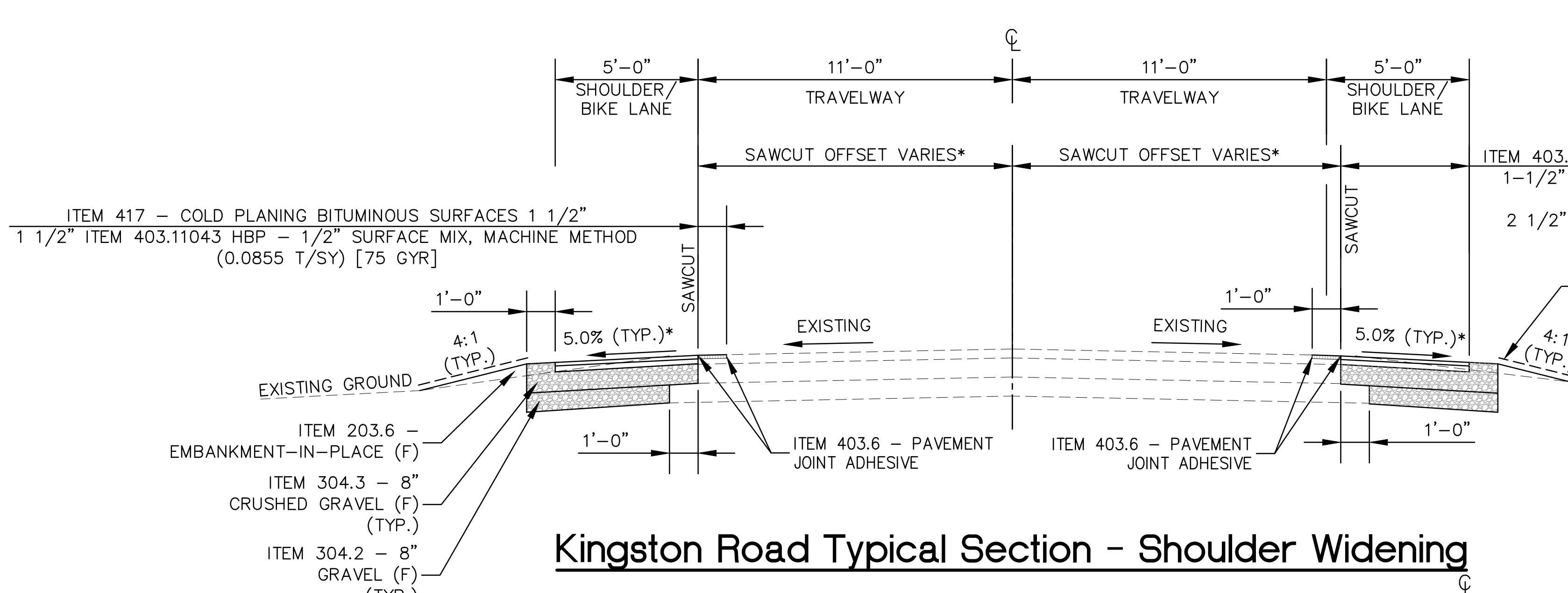

Table with 2 columns: designed by: JJB/STF, drawn by: ATR/STF, approved by: JJB. Includes date April 2023, project no: 1030, and file name: 1030-Notes.dwg.

Project title block: Town of Exeter, New Hampshire Public Works Department, Kingston Road TAP Project, Exeter 40436, X-A004(406), Legend and Abbreviations.



Kingston Road Typical Section - Shoulder Widening

Sta. 102+98 LT - Sta. 104+59 LT
Sta. 107+23 LT - Sta. 119+55 LT
Sta. 120+03 LT - Sta. 129+93 LT
Sta. 130+43 LT - Sta. 135+09 LT
Sta. 137+50 LT - Sta. 150+14 LT
Sta. 150+77 LT - Sta. 156+60 LT

Sta. 101+81 RT - Sta. 104+58 RT
Sta. 108+24 RT - Sta. 125+80 RT
Pickpocket Road

Not to Scale

SIDEWALK CROSS SLOPE TRANSITION TABLE	
STATION	CROSS SLOPE
135+50	-1.67%
135+60	1.67%
138+60	1.67%
138+70	-1.67%
148+10	-1.67%
148+20	1.67%
151+40	1.67%
151+50	-1.67%

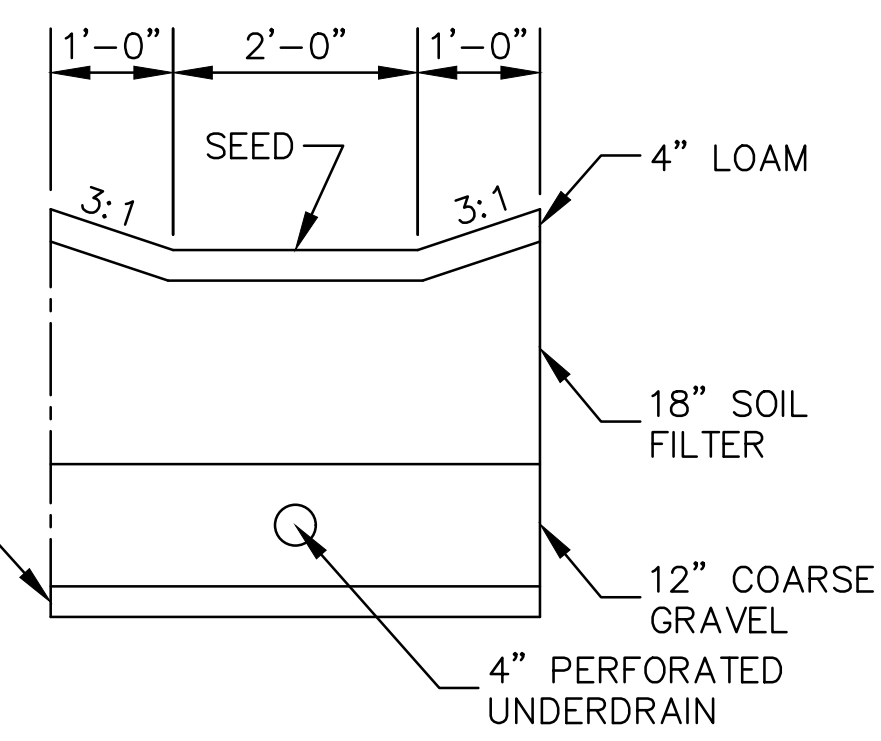

Bioretention Swale Detail

Sta. 128+00 RT - Sta. 129+83 RT
Sta. 134+10 RT to Sta. 136+50 RT
Sta. 148+10 RT to Sta. 151+54 RT

- Not to Scale
- ALL ITEMS SHOWN ON THIS DETAIL SHALL BE PAID FOR UNDER ITEM 645.99 BIORETENTION SWALE.
 - SOIL FILTER SHALL CONFORM TO THE GRADATION REQUIREMENTS OF EITHER OPTION A OR OPTION B IN TABLE 4-4.

Component Material	Percent of Mixture by Volume	Gradation of Material	
		Sieve No.	Percent by Weight Passing Standard Sieve
Filter Media Option A			
ASTM C-33 concrete sand	50 to 55		
Loamy sand topsoil, with fines as indicated	20 to 30	200	15 to 25
Moderately fine shredded bark or wood fiber mulch, with fines as indicated	20 to 30	200	< 5
Filter Media Option B			
Moderately fine shredded bark or wood fiber mulch, with fines as indicated	20 to 30	200	< 5
	70 to 80	10	85 to 100
		20	70 to 100
		60	15 to 40
Loamy coarse sand		200	8 to 15

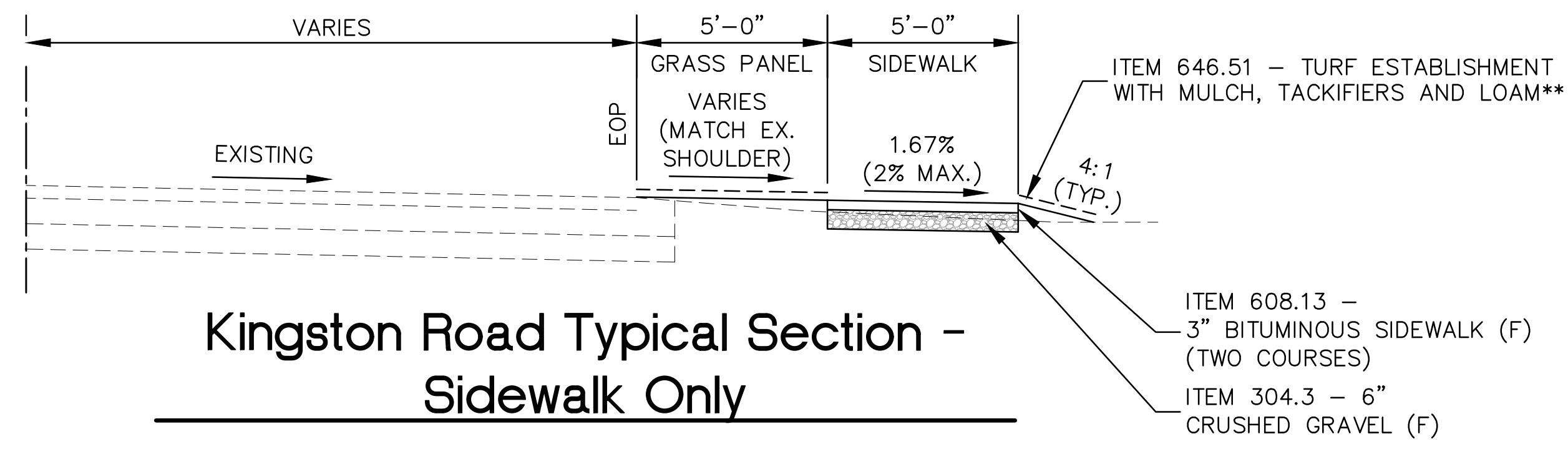

Kingston Road Typical Section - Sidewalk Only

Sta. 126+92 RT - Sta. 127+73 RT
Not to Scale

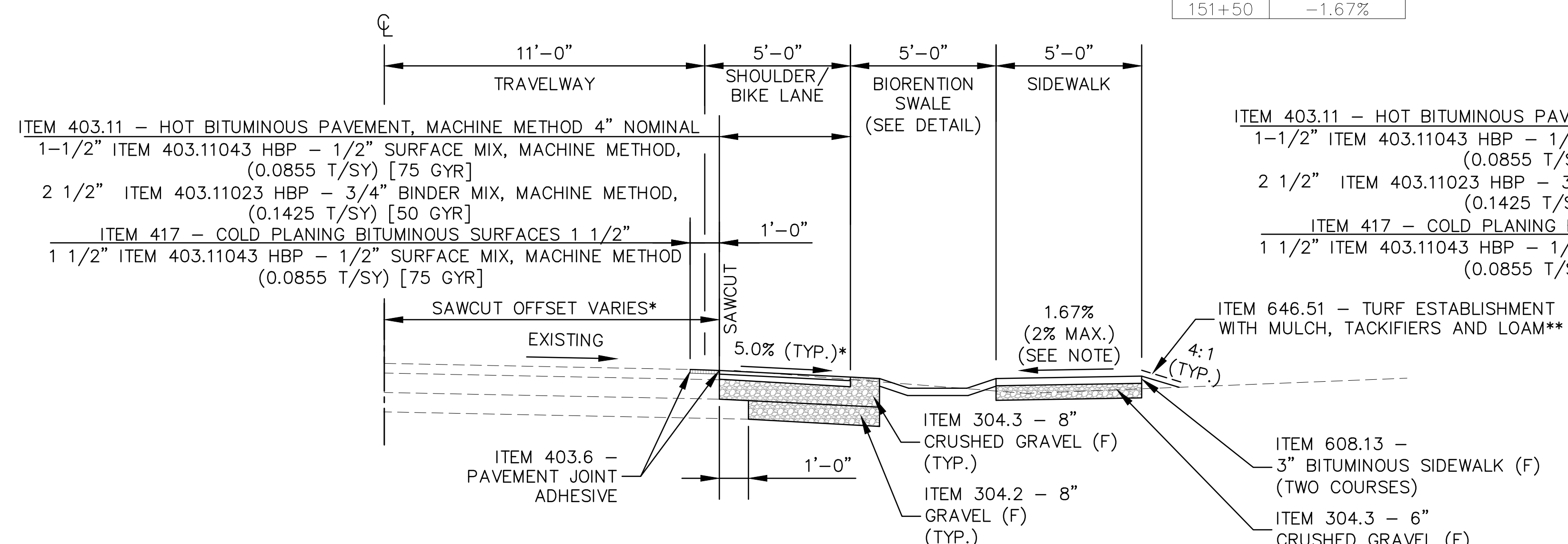

Kingston Road Typical Section - Shoulder Widening and Sidewalk

Sta. 135+50 RT - Sta. 136+50 RT
Sta. 148+10 RT - Sta. 151+50 RT
Not to Scale

NOTE: FOR SIDEWALK CROSS SLOPE TRANSITION LOCATIONS, SEE SIDEWALK CROSS SLOPE TRANSITION TABLE THIS SHEET.

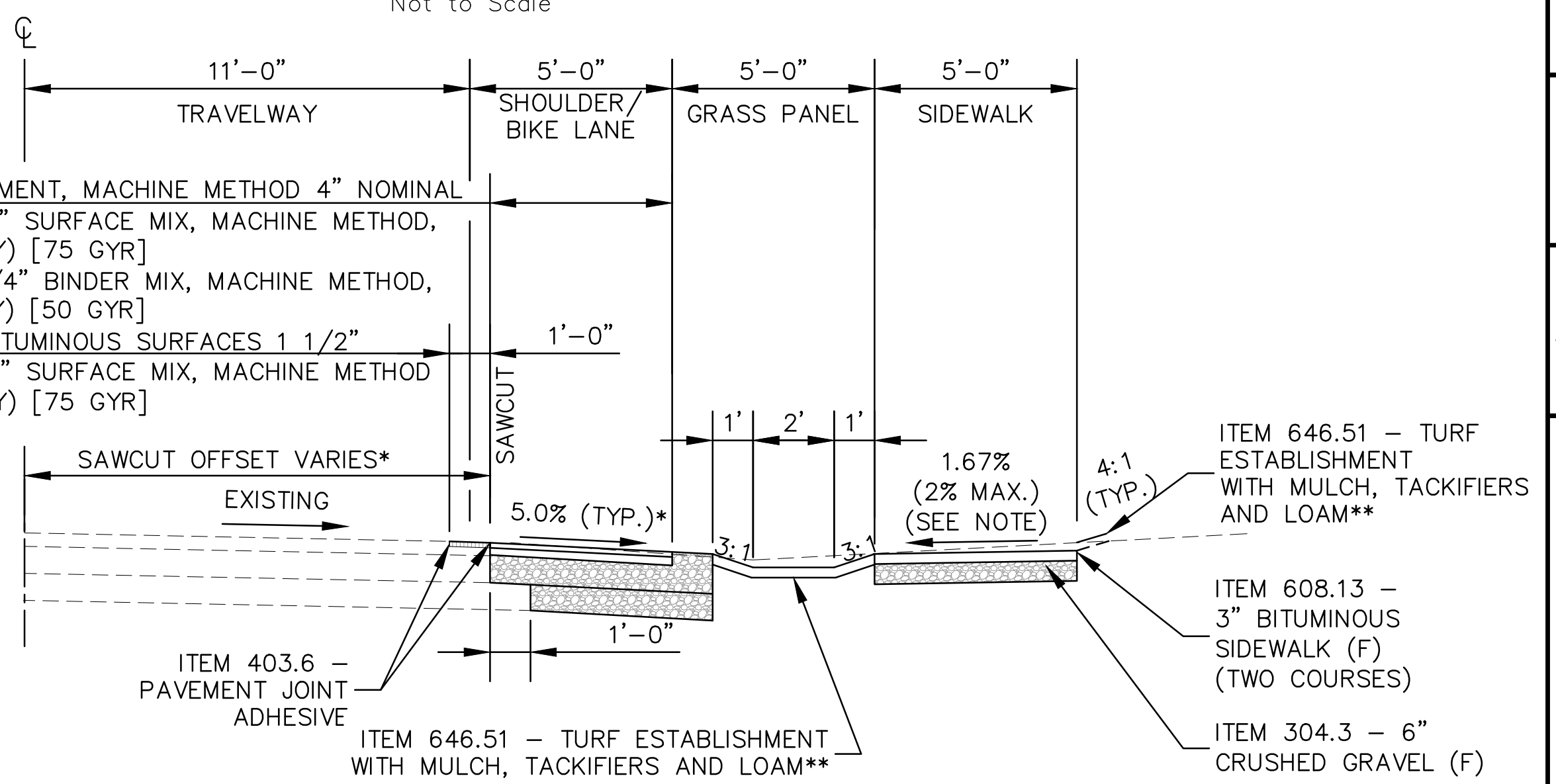

Kingston Road Typical Section - Shoulder Widening and Sidewalk

Sta. 136+50 RT - Sta. 138+70 RT
Not to Scale

NOTE: FOR SIDEWALK CROSS SLOPE TRANSITION LOCATIONS, SEE SIDEWALK CROSS SLOPE TRANSITION TABLE THIS SHEET.

designed by: JUB/STF	drawn by: ATP/STF	approved by: JUB	scale: 10:30-Typical.dwg
date: April 2023	project no: 1030	file name: 1030-Typical.dwg	scale: 10:30-Typical.dwg
<p>Town of Exeter, New Hampshire Public Works Department Kingston Road TAP Project Exeter 40436, X-A004(406) Typical Sections</p>			
drawing no. TYP-1			
sheet: 4 of 42			

CMA ENGINEERS
CIVIL/ENVIRONMENTAL/STRUCTURAL

Portland, ME
Manchester, NH
Portsmouth, NH
603/431-6196 • 603/627-0708 • 207/541-4223

c m a e n g i n e e r s . c o m

STATE OF NEW HAMPSHIRE
JASON J. W. BEADLER
LICENSED PROFESSIONAL ENGINEER
4/31/2023

4/3/2023
JUB
by
date
revision
1
Issued for Bidding

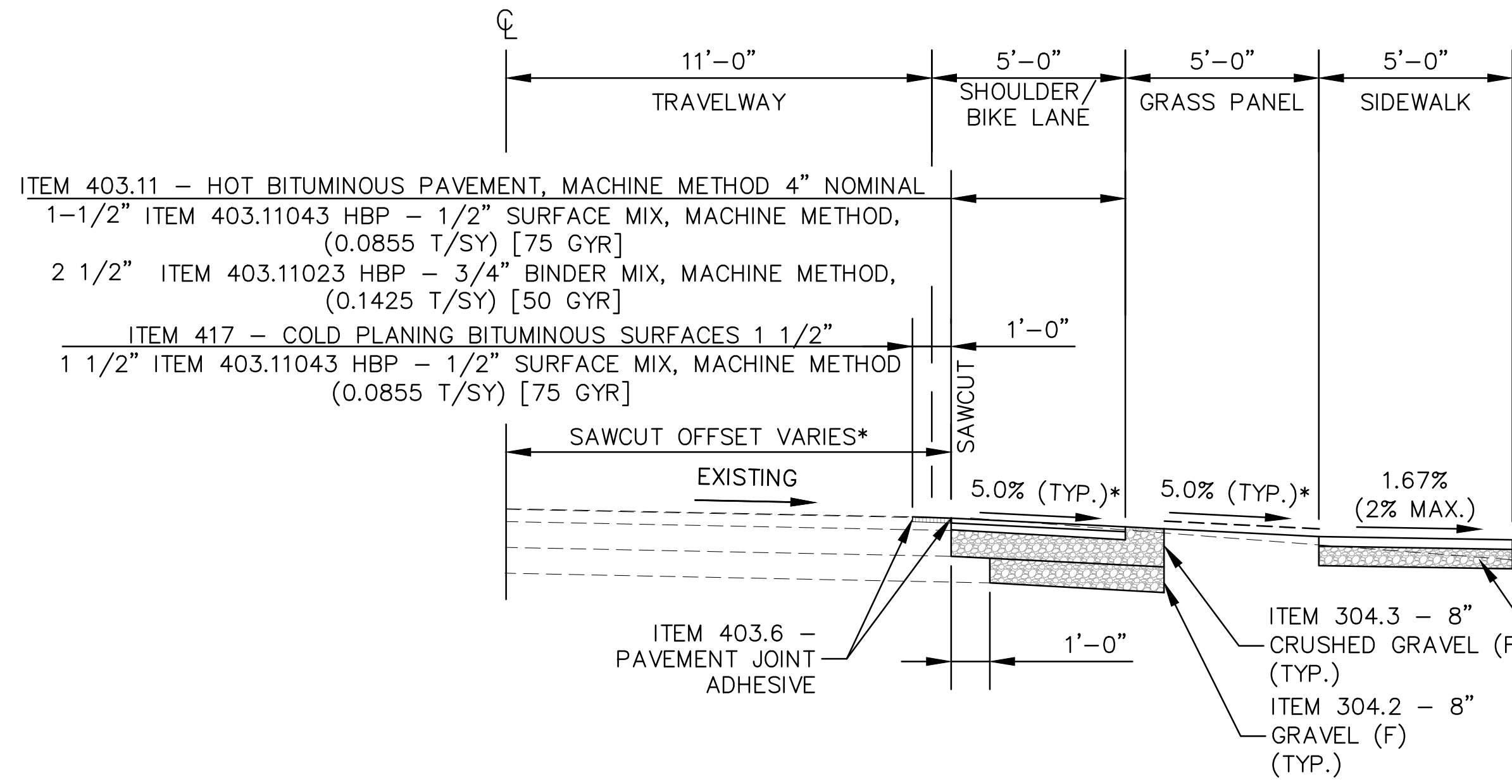

Kingston Road Typical Section - Shoulder Widening and Sidewalk

Sta. 127+73 RT - Sta. 135+50 RT
 Sta. 143+87 RT - Sta. 148+10 RT
 Sta. 151+50 RT - Sta. 153+37 RT
 Not to Scale

- ITEM 403.11 - HOT BITUMINOUS PAVEMENT, MACHINE METHOD 4" NOMINAL
 - 1-1/2" ITEM 403.11043 HBP - 1/2" SURFACE MIX, MACHINE METHOD, (0.0855 T/SY) [75 GYR]
 - 2 1/2" ITEM 403.11023 HBP - 3/4" BINDER MIX, MACHINE METHOD, (0.1425 T/SY) [50 GYR]
- ITEM 417 - COLD PLANING BITUMINOUS SURFACES 1 1/2"
 - 1 1/2" ITEM 403.11043 HBP - 1/2" SURFACE MIX, MACHINE METHOD (0.0855 T/SY) [75 GYR]
- ITEM 646.51 - TURF ESTABLISHMENT WITH MULCH, TACKIFIERS AND LOAM**
- ITEM 403.6 - PAVEMENT JOINT ADHESIVE
- ITEM 304.3 - 8" CRUSHED GRAVEL (F) (TYP.)
- ITEM 203.6 - EMBANKMENT-IN-PLACE (F)
- ITEM 608.13 - 3" BITUMINOUS SIDEWALK (F) (TWO COURSES)
- ITEM 304.3 - 6" CRUSHED GRAVEL (F)

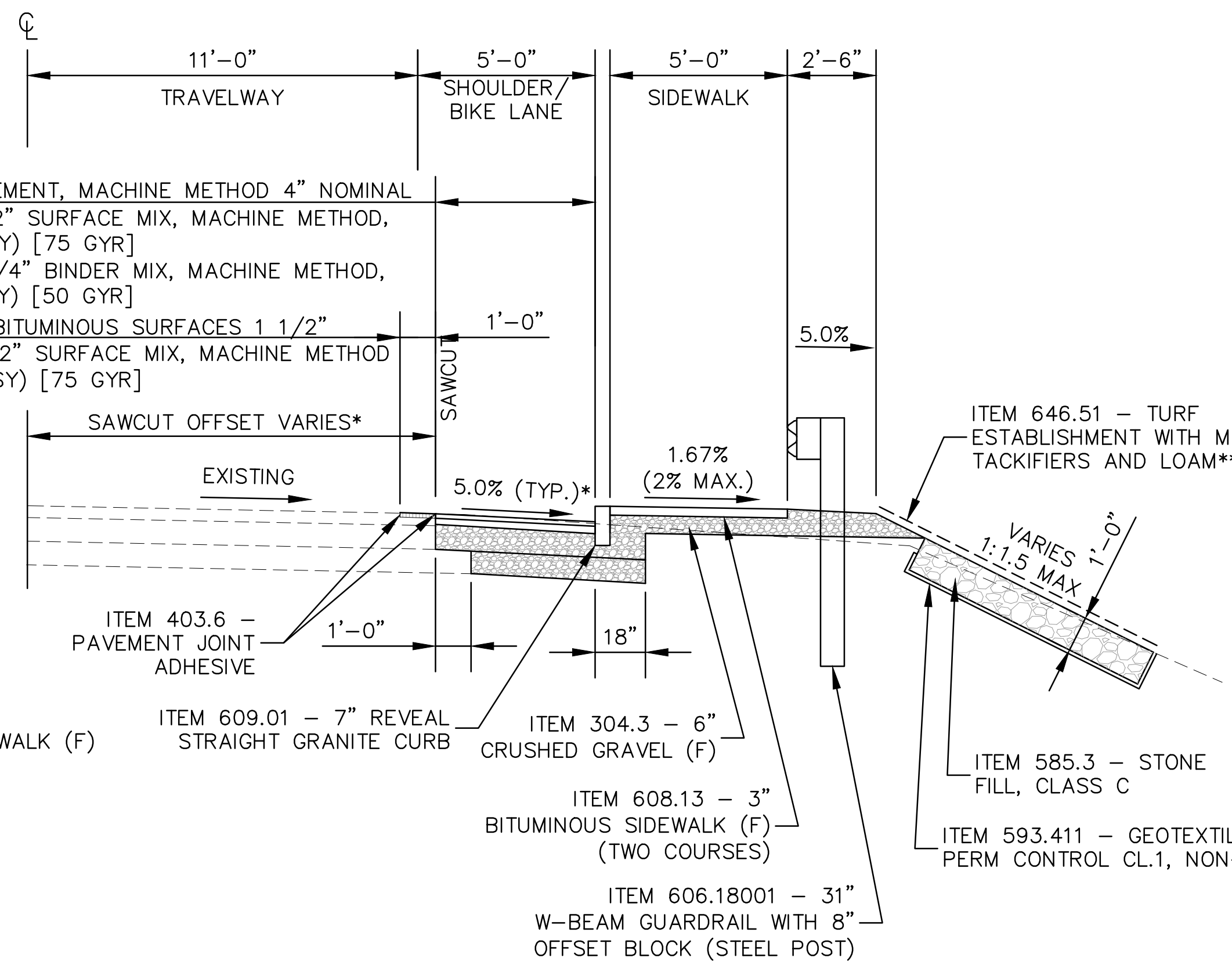

Kingston Road Typical Section - Shoulder Widening and Sidewalk With Curb

Sta. 153+37 RT - Sta. 156+60 RT
 Not to Scale

NOTE: STONE FILL AND GEOTEXTILE ONLY REQUIRED WHERE SLOPE IS STEEPER THAN 2:1.

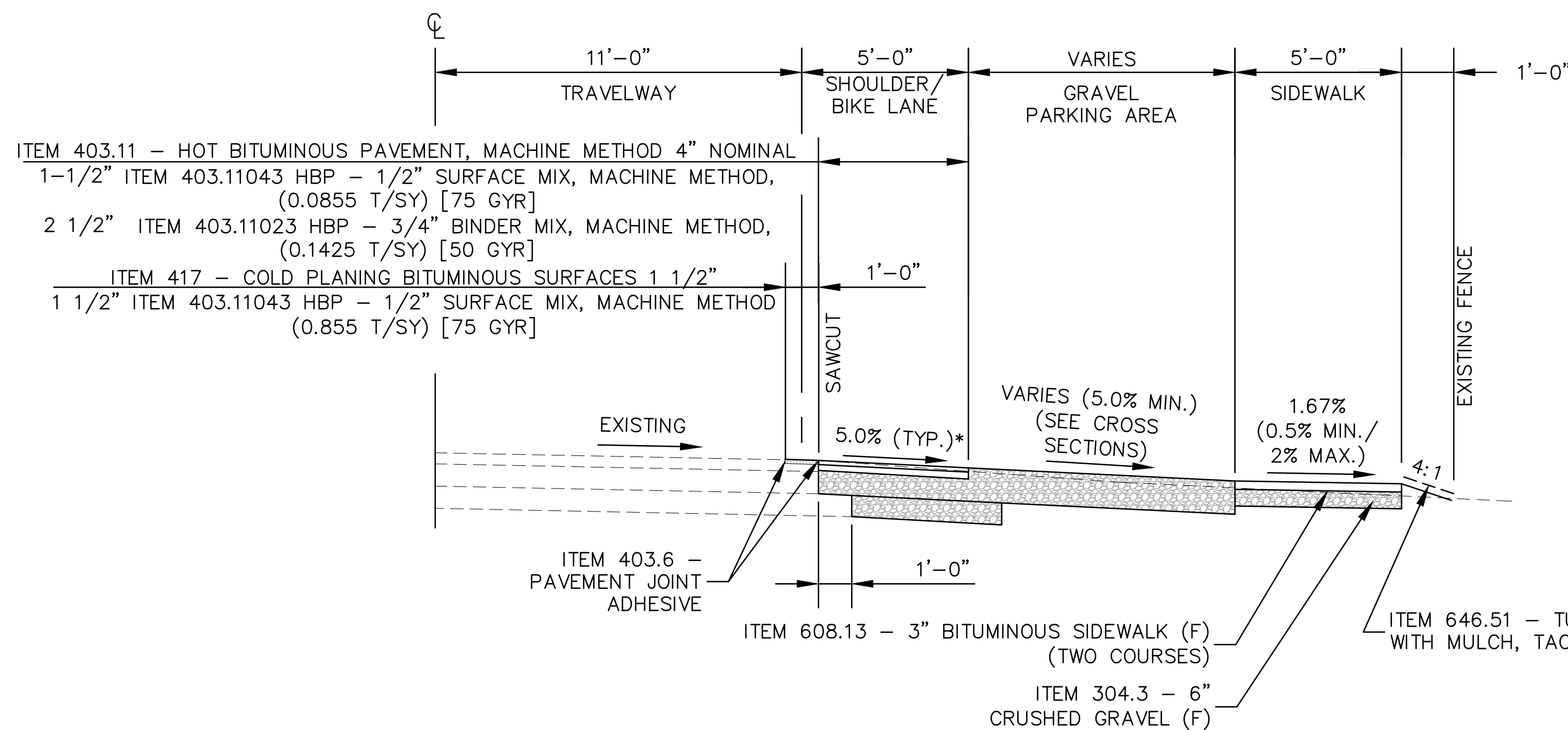

Kingston Road Typical Section - Shoulder Widening and Gravel Parking

Sta. 138+70 RT - Sta. 143+87 RT
 Not to Scale

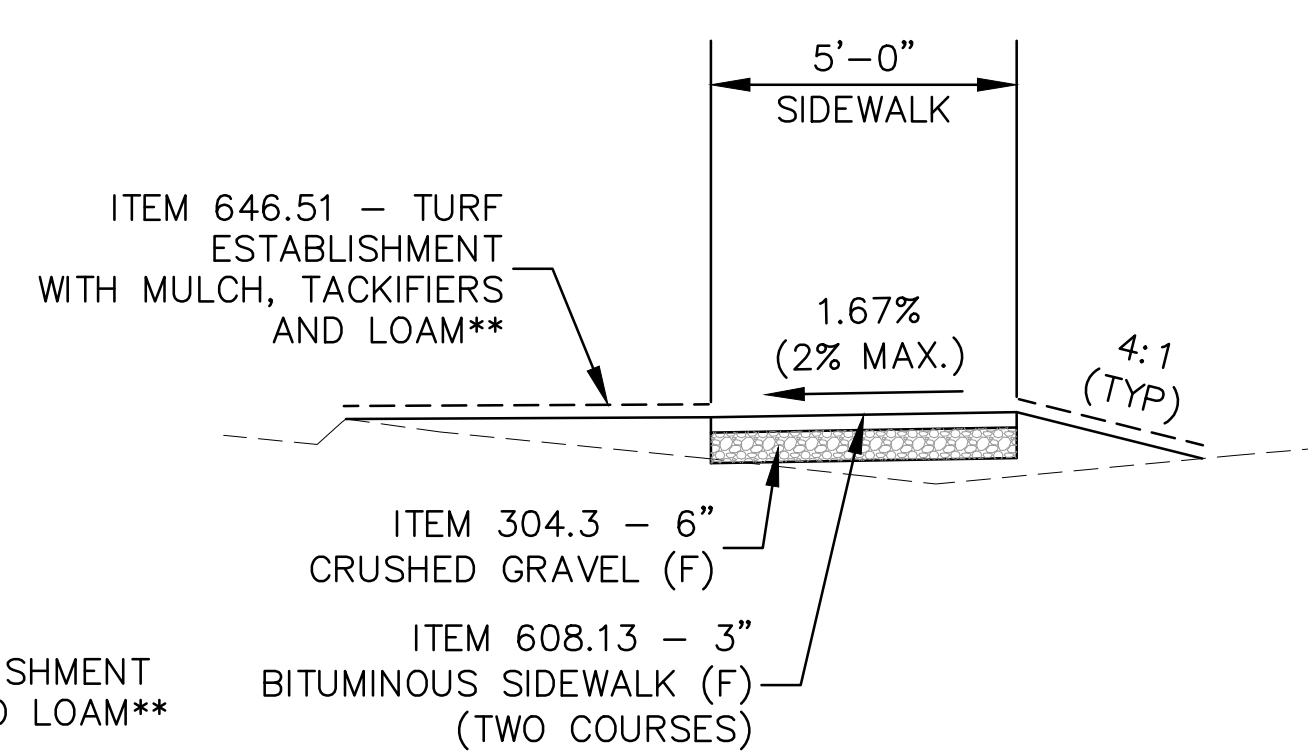

White Oak Drive Sidewalk Typical Section

Sta. 40+30 RT - Sta. 40+80 RT
 Not to Scale

SAWCUT AND SHOULDER SLOPE TABLE				
LEFT SIDE			RIGHT SIDE	
SHOULDER SLOPE	SAWCUT OFFSET (FT)	STATION	SAWCUT OFFSET (FT)	SHOULDER SLOPE
-	-	101+80	10.5	-5.00%
-5.00%	11.5	102+98	10.5	-5.00%
-5.00%	11.5	104+58	10.5	-5.00%
-5.00%	11.5	104+59	-	-
-5.00%	22	107+23	-	-
-5.00%	22	108+24	11	-5.00%
-5.00%	22	109+60	11	-5.00%
-5.00%	11	110+60	11	-5.00%
-5.00%	11	119+55	11	-5.00%
-5.00%	11.5	120+03	11	-5.00%
-5.00%	11.5	133+00	11	-5.00%
-1.40%	11.5	133+50	11	-EX.%
-1.40%	11.5	134+25	11.5	-EX.%
-1.40%	11.5	135+50	11.5	-EX.%
-5.00%	11	136+00	11.5	-5.00%
-5.00%	11	142+00	11.5	-5.00%
-2.50%	11	142+50	11.5	-5.00%
-2.50%	11	143+00	11.5	-5.00%
-2.50%	11	143+50	11.5	-EX.%
-2.50%	11	144+50	11.5	-EX.%
-5.00%	11	145+00	11.5	-EX.%
-5.00%	11	147+00	11.5	-EX.%
-5.00%	11	147+50	11.5	-5.00%
-EX.%	11	150+77	11.5	-5.00%
-EX.%	11	151+50	11.5	-5.00%
-EX.%	11	152+00	11.5	-3.45%
-EX.%	11	153+50	11.5	-3.45%
-5.00%	11	154+00	11.5	-3.45%
-5.00%	11	154+50	11.5	-3.45%
-5.00%	11	155+00	11.5	-5.00%
-5.00%	11	156+60	11.5	-5.00%

*SEE SAWCUT AND SHOULDER SLOPE TABLE THIS SHEET
 **IN AREAS WHERE PROPOSED SIDE SLOPE TIES INTO EXISTING GRAVEL SHOULDER, SIDE SLOPE TREATMENT SHALL BE 4" OF ITEM 304.3 - CRUSHED GRAVEL (F) WITHOUT TURF ESTABLISHMENT

designed by: JUB/STF
 date: April 2023
 project no: 1030
 file name: 1030-Typical.dwg
 scale:
 drawn by: ATR/STF
 approved by: JUB
 revision: 1
 date: 4/3/2023
 issued for Bidding
 no. 1
 by

CMA ENGINEERS
 CIVIL/ENVIRONMENTAL/STRUCTURAL
 Portsmouth, NH • Manchester, NH • Portland, ME
 603/431-6196 • 603/627-0708 • 207/541-4223
 c m a e n g i n e e r s . c o m

Town of Exeter, New Hampshire
Public Works Department
Kingston Road TAP Project
Exeter 40436, X-A004(406)
Typical Sections

drawing no. **TYP-2**
 sheet: 5 of 42

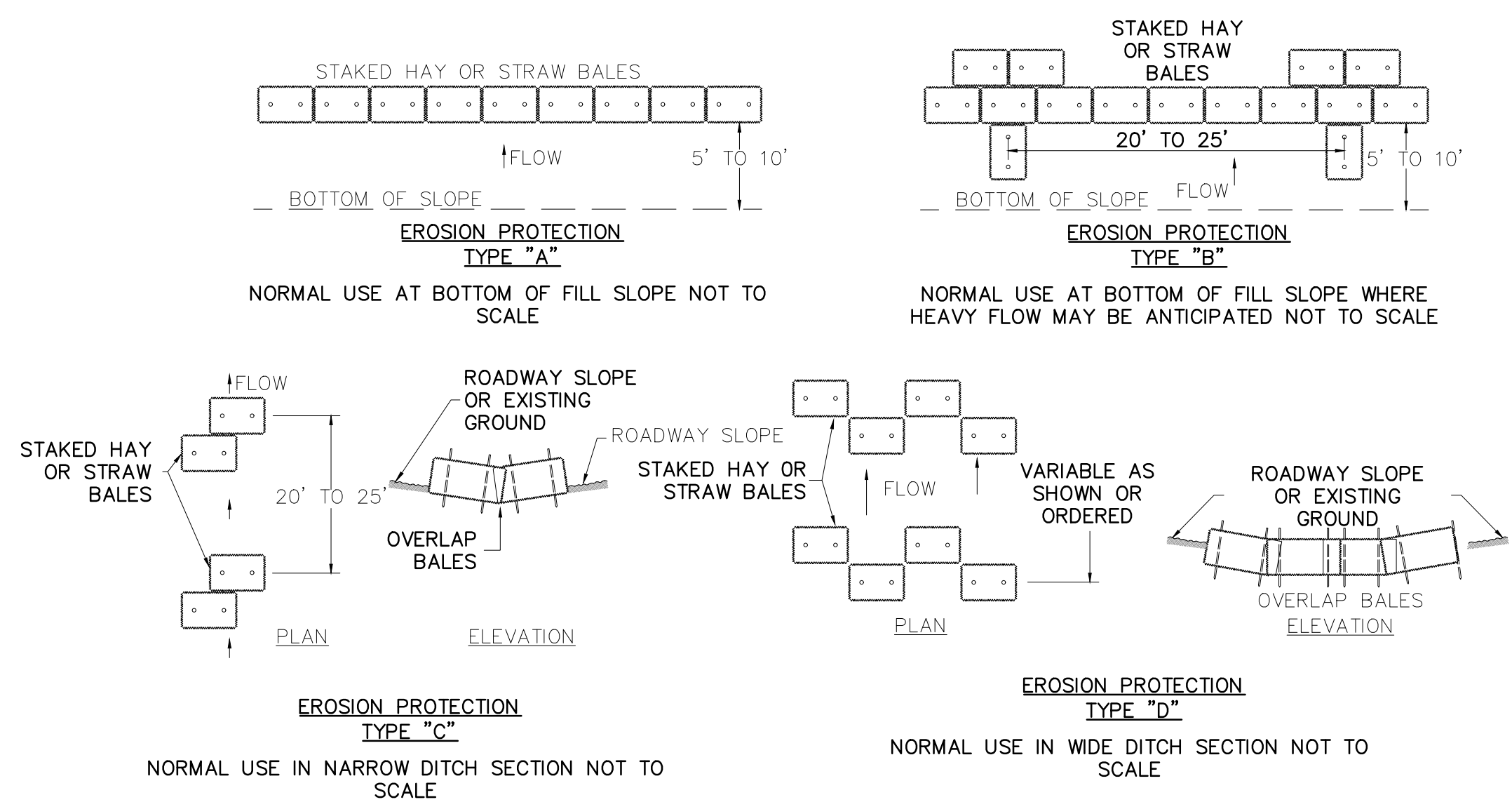

Hay Bale Detail

Not to Scale

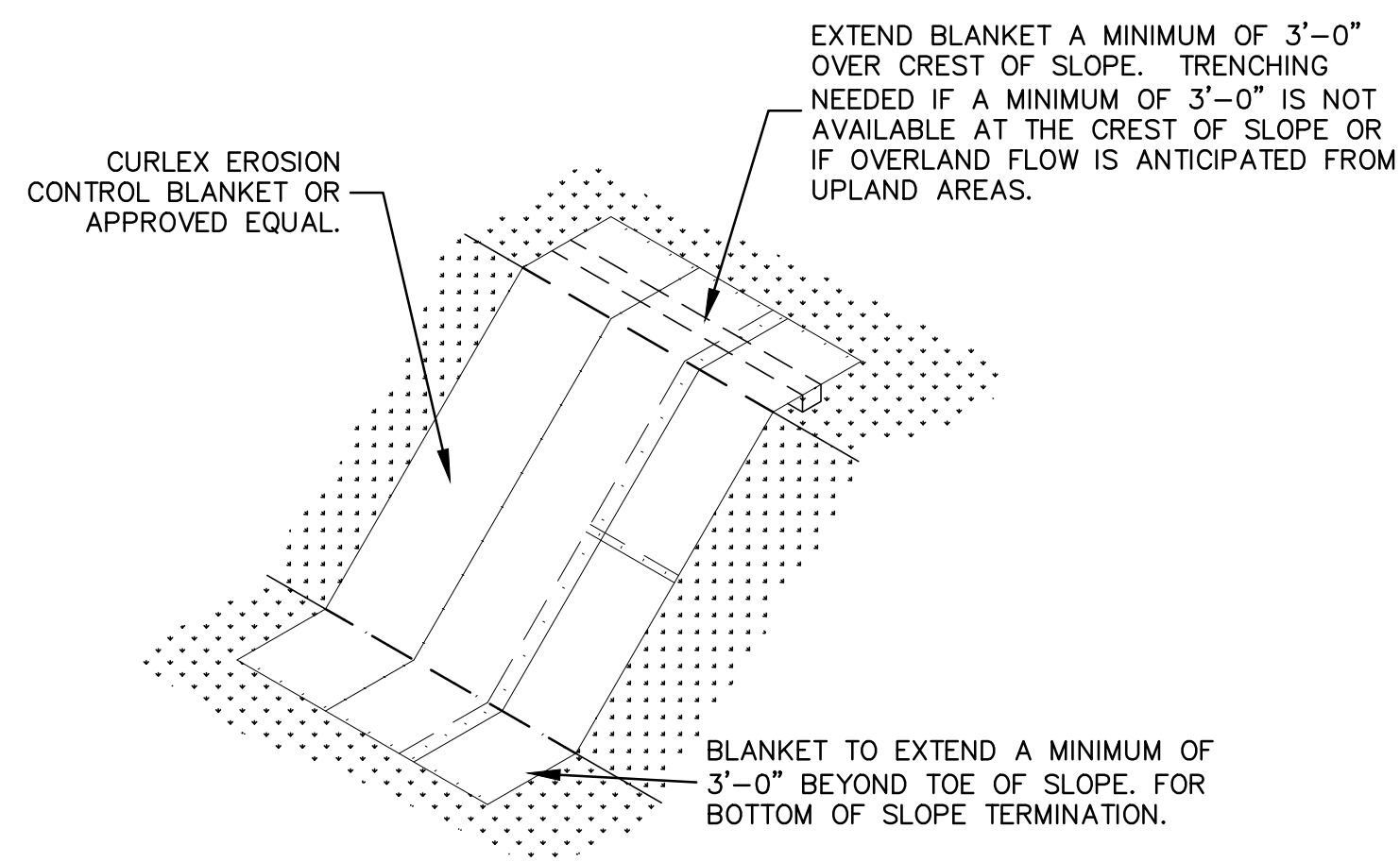

Erosion Control Blanket Detail

Not to Scale

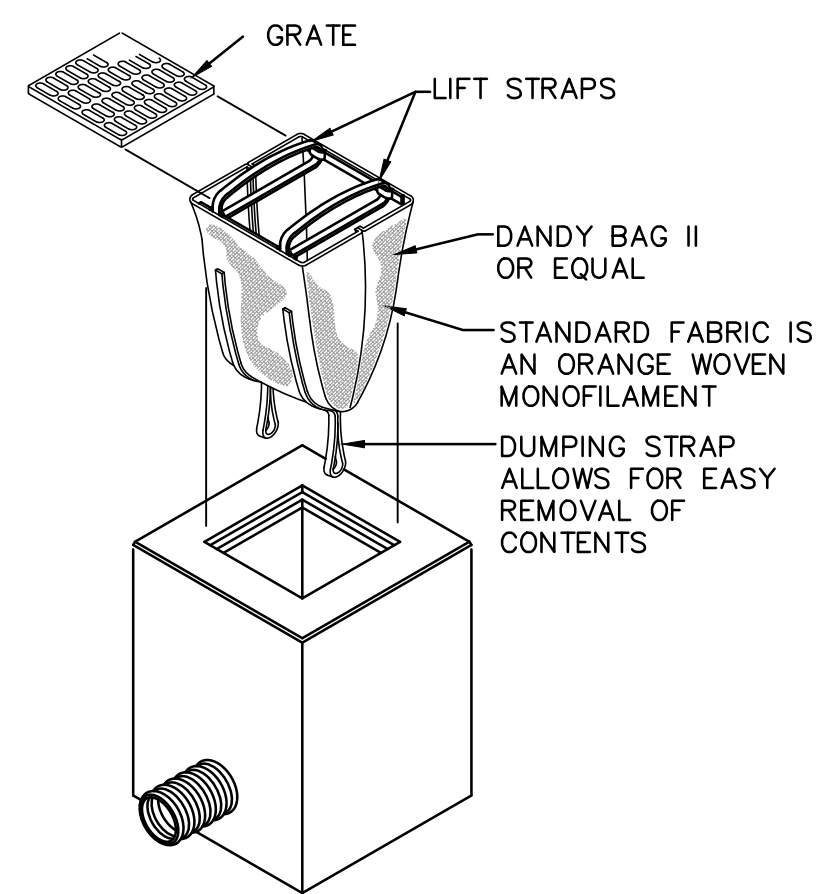

Inlet Protection Detail

Not to Scale

INSTALLATION AND MAINTENANCE GUIDELINES:

INSTALLATION: REMOVE THE GRATE FROM CATCH BASIN. IF USING OPTIONAL OIL ABSORBENTS; PLACE ABSORBENT PILLOW IN UNIT. STAND THE GRATE ON END. MOVE THE TOP LIFTING STRAPS OUT OF THE WAY AND PLACE THE GRATE INTO THE CATCH BASIN INSERT SO THAT THE GRATE IS BELOW THE TOP STRAPS AND ABOVE THE LOWER STRAPS. HOLDING THE LIFTING DEVICES, INSERT THE GRATE INTO THE INLET.

MAINTENANCE: REMOVE ALL ACCUMULATED SEDIMENT AND DEBRIS FROM VICINITY OF UNIT AFTER EACH STORM EVENT. AFTER EACH STORM EVENT AND AT REGULAR INTERVALS, LOOK INTO THE CATCH BASIN INSERT. IF THE CONTAINMENT AREA IS MORE THAN 1/3 FULL OF SEDIMENT, THE UNIT MUST BE EMPTIED. TO EMPTY UNIT, LIFT THE UNIT OUT OF THE INLET USING THE LIFTING STRAPS AND REMOVE THE GRATE. IF USING OPTIONAL OIL ABSORBENTS; REPLACE ABSORBENT WHEN NEAR SATURATION.

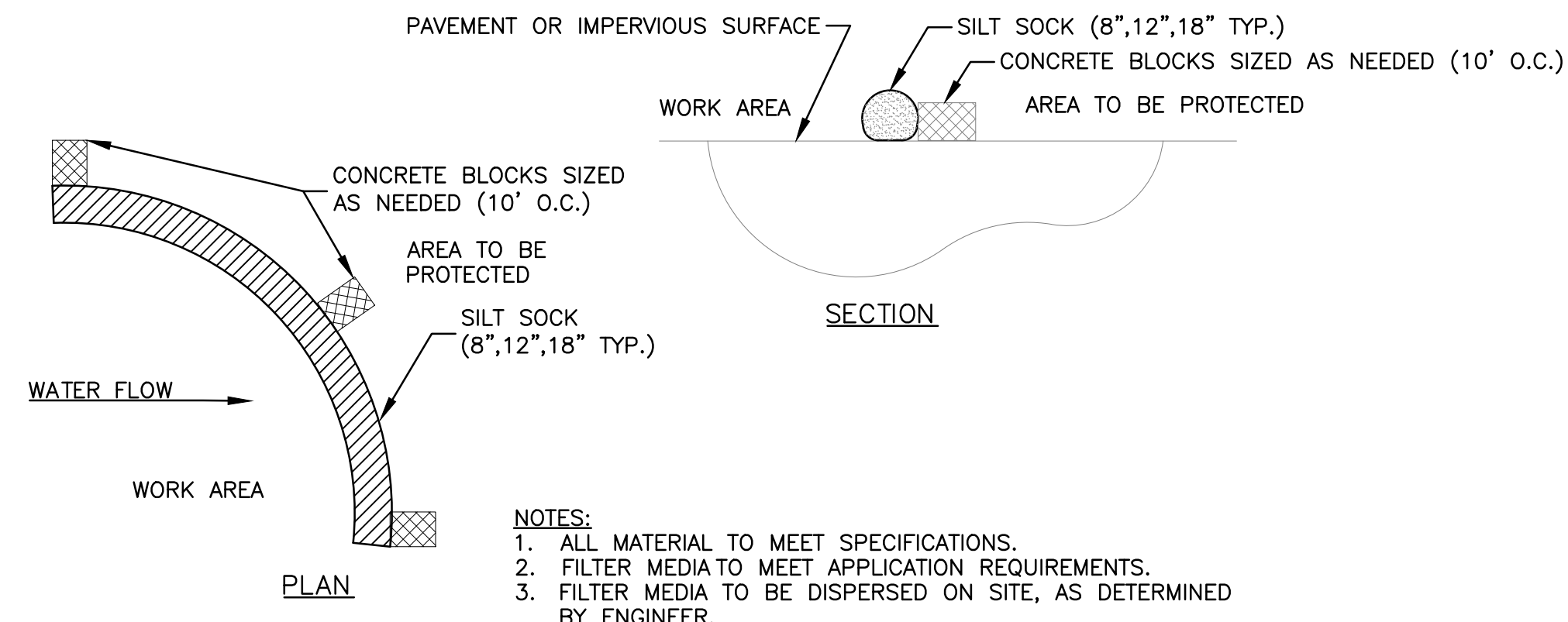

Silt Sock for Pavement

Not to Scale

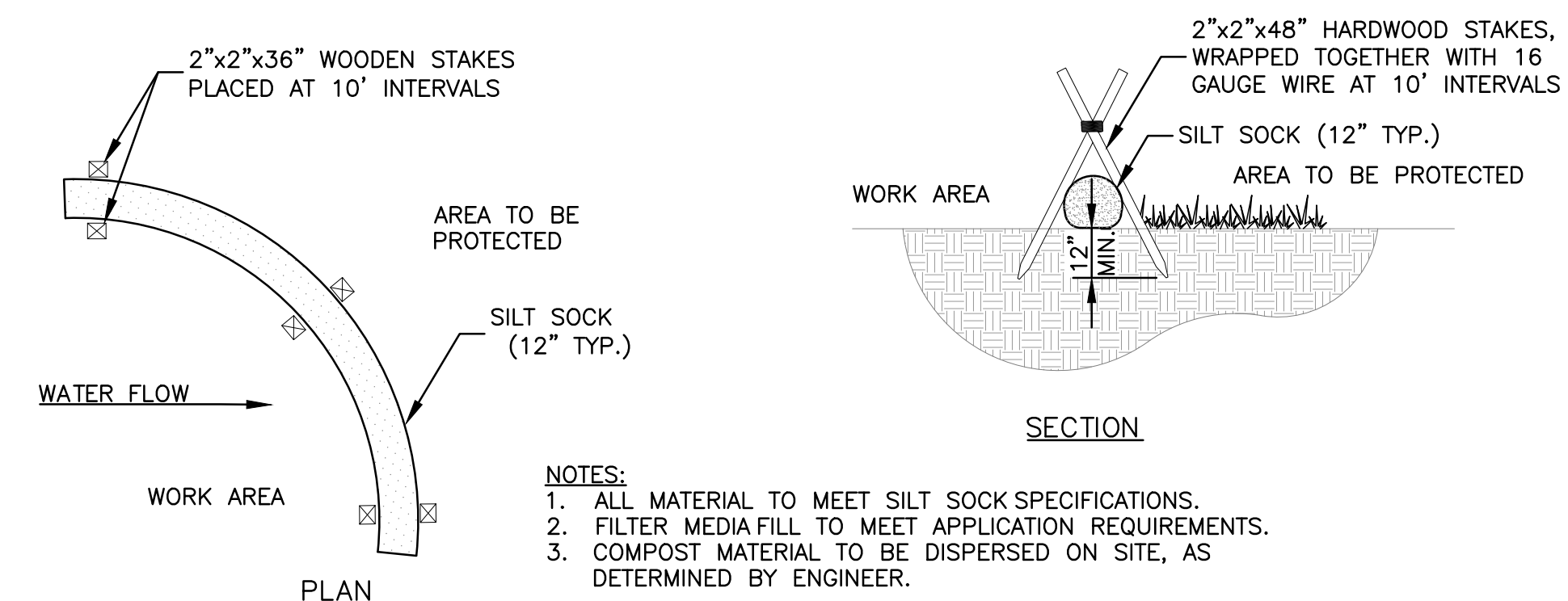

Silt Sock Detail

Not to Scale

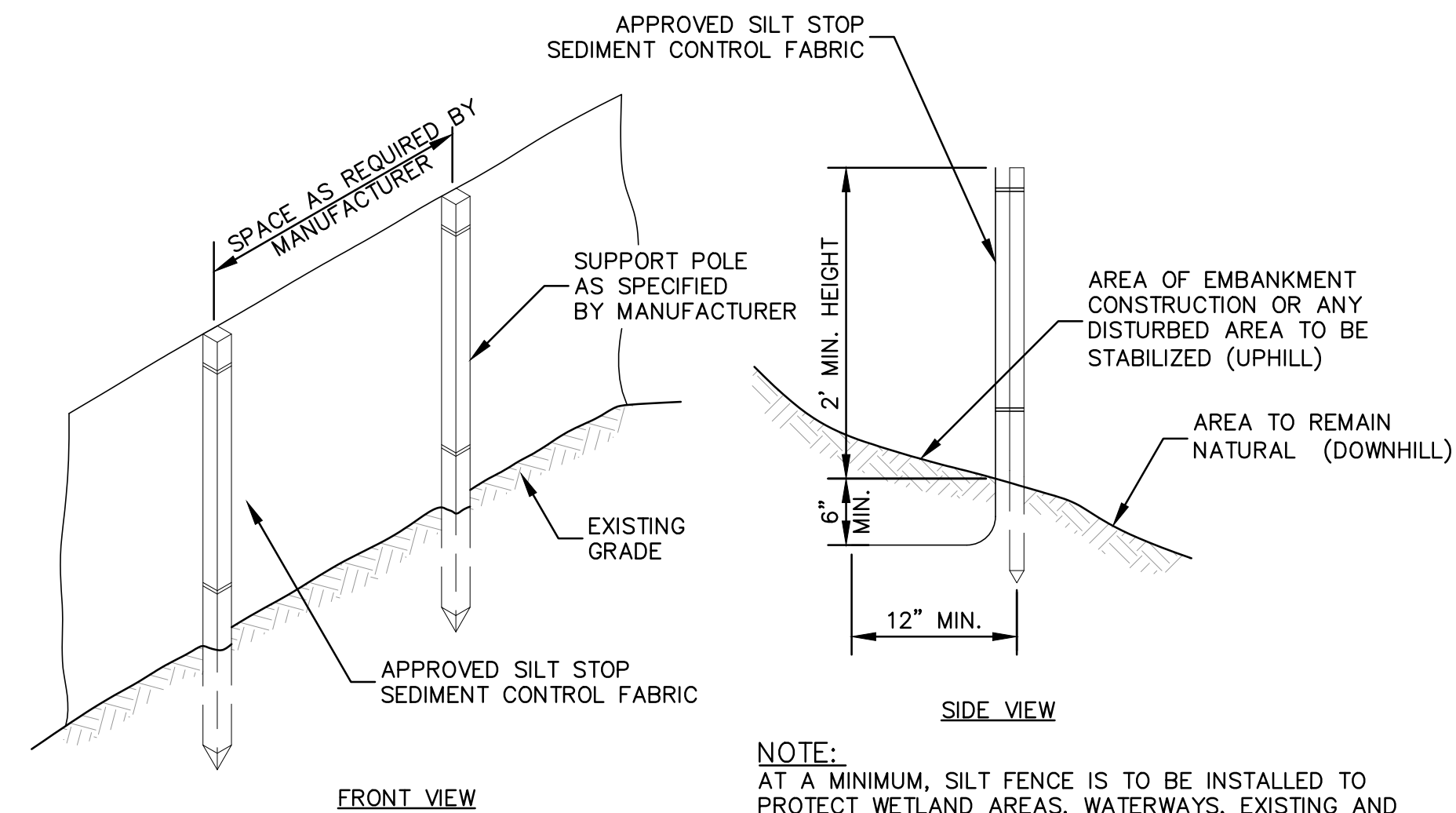

Silt Fence Detail

Not to Scale

no.	1	Issued for Bidding	4/3/2023	JJB	by
revision			date		

CMA ENGINEERS
CIVIL/ENVIRONMENTAL/STRUCTURAL

Portland, ME
Manchester, NH • 207/541-4223
Portsmouth, NH • 603/627-0708
603/431-6196

c m a e n g i n e e r s . c o m

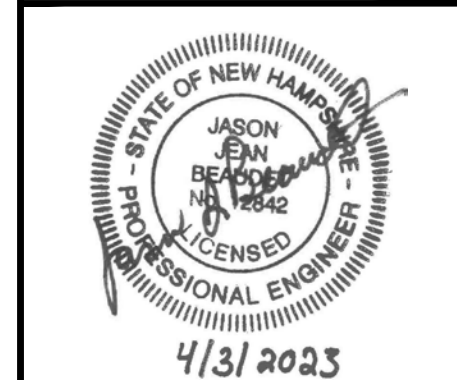

date:	April 2023	designed by:	JJB/STF
project no.:	1030	drawn by:	ATR/STF
file name:	1030-Details.dwg	approved by:	JJB
scale:			

Town of Exeter, New Hampshire
Public Works Department
Kingston Road TAP Project
Exeter 40436, X-A004(406)

Erosion Control
Detail Sheet

GENERAL NOTES:

- THIS SHEETS ARE IN ACCORDANCE WITH THE AMERICANS WITH DISABILITIES ACT (ADA), AND THE REQUIREMENTS OF THE 2011 PROPOSED ACCESSIBILITY GUIDELINES FOR PEDESTRIAN FACILITIES IN THE PUBLIC RIGHT OF WAY (PROWAG).
- NOT ALL FACILITIES CAN BE CONSTRUCTED TO MEET THE DESIGN STANDARDS. FACILITIES THAT CANNOT BE CONSTRUCTED TO MEET THE DESIGN STANDARDS SHALL BE CONSTRUCTED TO MEET THE STANDARDS TO THE GREATEST EXTENT PRACTICABLE. NONSTANDARD FEATURES SHALL BE DOCUMENTED ON TECHNICAL INFESABILITY FORM AND SUBMITTED TO NHDOT ADA COORDINATOR FOR APPROVAL.
- TO CHECK FIELD LAYOUT ALL SLOPES AND GRADES SHALL BE MEASURED WITH A DIGITAL LEVEL USING AT LEAST TWO READINGS. WHERE THE READINGS VARY, THE MEASUREMENTS SHALL BE AVERAGED. GRADE (RUNNING SLOPE) SHALL BE MEASURED ALONG THE CENTERLINE AND OFFSET 1.00' TO 1.50' FROM THE CENTERLINE. CROSS SLOPES SHALL BE MEASURED PERPENDICULAR TO CENTERLINE AT 5.00' TO 10.00' INTERVALS.
- GRADES (RUNNING SLOPES) ARE MEASURED IN THE DIRECTION OF PEDESTRIAN TRAVEL. CROSS SLOPES ARE MEASURED PERPENDICULAR TO THE DIRECTION OF PEDESTRIAN TRAVEL.
- JOINTS BETWEEN SIDEWALKS, CURB RAMPS, TURNING SPACES AND ROADWAYS SHALL BE FLUSH AND FREE FROM ABRUPT VERTICAL CHANGES GREATER THAN 1/4". VERTICAL SURFACE DISCONTINUITIES BETWEEN 1/4" AND 1/2" SHALL BE BEVELED WITH A SLOPE NOT STEEPER THAN 2:1. THE BEVEL SHALL BE APPLIED ACROSS THE ENTIRE JOINT. SEE DETAIL ON NHDOT'S SIDEWALK CURB RAMP DETAILS SHEET 9 OF 9.
- SIDEWALKS ARE CONNECTED TO ROADWAYS BY EITHER BLENDED TRANSITIONS OR CURB RAMPS. BLENDED TRANSITIONS ARE CONNECTIONS BETWEEN THE SIDEWALK LEVEL AND THE ROADWAY LEVEL THAT HAVE A MAXIMUM GRADE (RUNNING SLOPE) OF 5%, AND TRANSITIONS GREATER THAN 5% ARE CONSIDERED CURB RAMPS.
- CURB RAMPS AND BLENDED TRANSITIONS MAY REQUIRE THE INSTALLATION OF DETECTABLE WARNINGS. SEE ADDITIONAL "DETECTABLE WARNING DEVICE NOTES" ON THIS SHEET, AND NHDOT'S SIDEWALK CURB RAMP DETAILS SHEET 6 OF 9 FOR DIMENSIONS, ORIENTATION AND INSTALLATION.
- VERTICAL ALIGNMENT SHALL BE GENERALLY PLANAR. GRADE BREAKS WITHIN THE PEDESTRIAN ACCESS ROUTE SHALL BE PERPENDICULAR TO THE DIRECTION OF TRAVEL AND SHALL NOT BE ROUNDED.
- THE CROSS SLOPE OF PEDESTRIAN ACCESS ROUTES (PAR) SHALL BE 2% MAXIMUM. THE FOLLOWING EXCEPTIONS ARE ALLOWED:
 - WHERE PEDESTRIAN CROSSINGS ARE PROVIDED AT INTERSECTIONS WITHOUT YIELD OR STOP CONTROL OR WHERE THERE IS ANY TRAFFIC SIGNAL, THE CROSS SLOPE OF A PEDESTRIAN ACCESS ROUTE CONTAINED WITHIN A CROSSING SHALL BE 5% MAXIMUM.
 - WHERE MIDBLOCK PEDESTRIAN CROSSINGS ARE PROVIDED, THE CROSS SLOPE OF A PEDESTRIAN ACCESS ROUTE CONTAINED WITHIN A MIDBLOCK CROSSING SHALL BE PERMITTED TO EQUAL THE STREET OR HIGHWAY GRADE.
- THE MINIMUM CLEAR WIDTH FOR PEDESTRIAN ACCESS ROUTES IS 4.00', EXCLUSIVE OF THE CURB. WHEN WALKWAY WIDTHS ARE LESS THAN 5.00', 5.00' x 5.00' PASSING SPACES, OR A FEATURE OF EQUAL OR GREATER DIMENSIONS (E.G., DRIVEWAYS) THAT MEET THE SLOPE CRITERIA, SHALL BE PROVIDED AT A MAXIMUM INTERVAL OF 200'. EXISTING DRIVEWAYS AND STREET CROSSING MAY ALSO SERVE AS PASSING SPACES.
- THE BUFFER ZONE IS A PHYSICAL DISTANCE SEPARATING THE PEDESTRIAN ACCESS ROUTE FROM THE VEHICLE TRAVELED WAY. THE BUFFER ZONE MAY BE PLANTED OR PAVED.
- WHEN CROSSING DRIVEWAYS, THE WORK SHALL BE IN CONFORMANCE WITH NHDOT DRIVEWAY DETAILS SHEET. THE CROSS SLOPE ACROSS DRIVEWAYS SHALL BE 2% MAXIMUM.
- FOR ACCESSIBLE PEDESTRIAN SIGNAL PUSH BUTTONS, SEE NHDOT'S SIDEWALK CURB RAMP DETAILS SHEET 8 OF 9.
- FOR RAMP COUNTER SLOPE REQUIREMENTS, SEE NHDOT'S SIDEWALK CURB RAMP DETAILS SHEET 9 OF 9.

CURB RAMP NOTES:

- THE MINIMUM WIDTH OF A CURB RAMP SHALL BE 4.00'.
- THE FULL WIDTH OF THE RAMP OR LANDING SHALL BE CONTAINED WITHIN THE PAVEMENT MARKINGS AT MARKED CROSSWALKS.
- CURB RAMPS ARE NOT REQUIRED IN LOCATIONS WHERE THERE IS NO ACCESSIBLE PEDESTRIAN ACCESS ROUTE. UNLESS IT IS SERVING AS A LANDING FOR A PEDESTRIAN SIGNAL.
- THE GRADE (RUNNING SLOPE) OF A CURB RAMP SHALL BE A MAXIMUM OF 8.3%.
- WHERE EXISTING CONDITIONS DO NOT ALLOW THE CONSTRUCTION OF A CURB RAMP WITH A GRADE (RUNNING SLOPE) OF 8.3% OR LESS, THE RAMP LENGTH SHALL NOT BE REQUIRED TO EXCEED 15.00'.
- THE CROSS SLOPE OF THE CURB RAMP SHALL BE AS FLAT AS POSSIBLE AND STILL PROVIDE POSITIVE DRAINAGE. THE CROSS SLOPE OF A CURB RAMP SHALL BE 2% MAXIMUM. SEE NOTE 9 FOR EXCEPTIONS. WHERE THE EXISTING ROADWAY GRADE EXCEEDS 2% THE CURB RAMP MAY BE WARPED ACCORDING TO THE DETAIL ON NHDOT'S SIDEWALK CURB RAMP DETAILS SHEET 9 OF 9 TO TIE INTO THE ROADWAY GRADE.
- RAMP SIDE TREATMENT OPTIONS ARE DETAILED ON NHDOT'S SIDEWALK CURB RAMP DETAILS SHEET 7 OF 9 FOR USE WITHIN THE BUFFER ZONE. WHERE A PEDESTRIAN CIRCULATION PATH CROSSES THE CURB RAMP, FLARED SIDES SHALL BE INSTALLED WITH A SLOPE OF 10% MAXIMUM. THE SLOPE OF FLARED SIDES IS MEASURED PARALLEL TO THE CURB LINE. (ALSO SEE CURB RAMP CONFIGURATION TYPE 7 ON NHDOT'S SIDEWALK CURB RAMP DETAILS SHEET 3 OF 9.)
- THE BACKSIDE OF A PARALLEL RAMP SHOULD BE GRADED TO MATCH EXISTING TERRAIN, UNLESS OTHERWISE SHOWN IN THE CONTRACT DOCUMENTS. WHERE GRADING IS NOT FEASIBLE DUE TO LIMITED ROW OR PHYSICAL CONSTRAINTS, A BACK CURB MAY BE INSTALLED. SEE NHDOT'S SIDEWALK CURB RAMP DETAILS SHEET 7 OF 9.

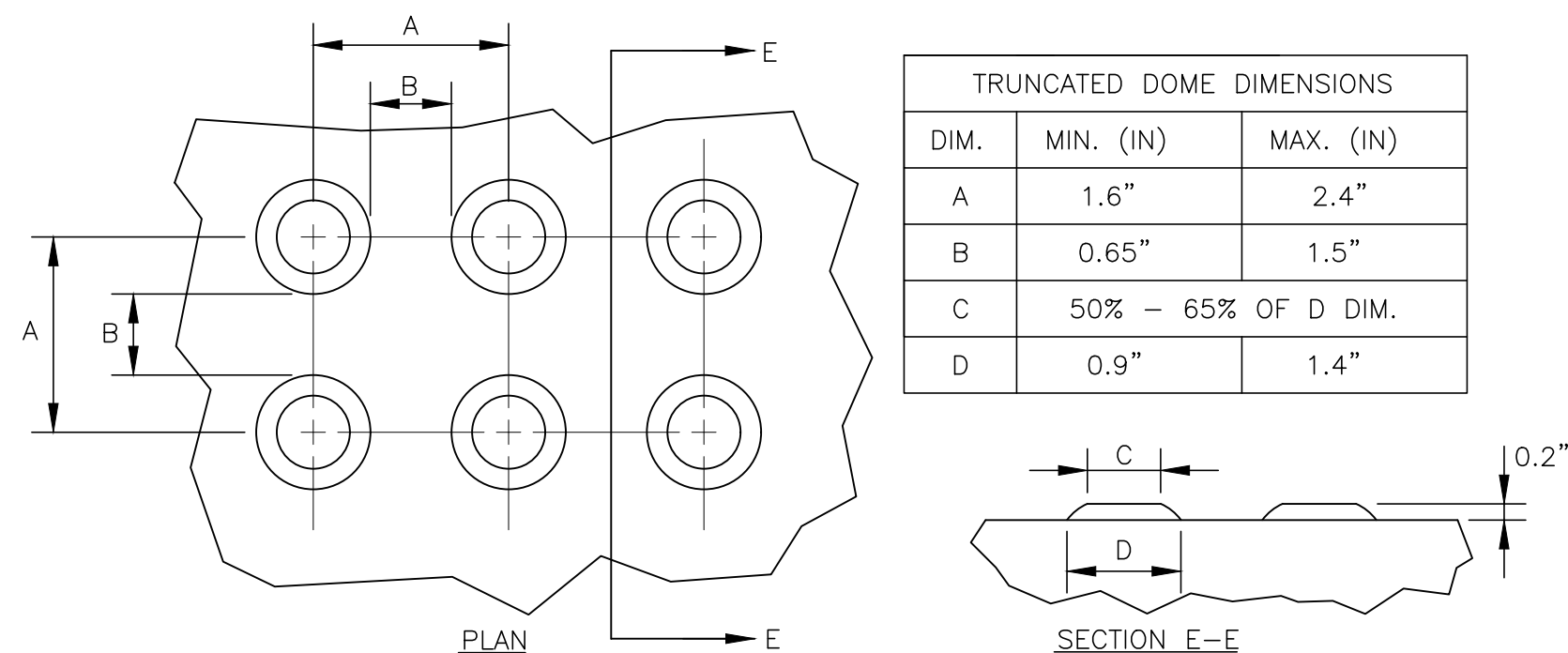

DETECTABLE WARNING DEVICES (DWD) TRUNCATED DOME DETAILS

TURNING SPACE AND CLEAR SPACE NOTES:

- WHERE A CHANGE IN DIRECTION IS REQUIRED TO UTILIZE A CURB RAMP, A TURNING SPACE SHALL BE PROVIDED AT THE BASE AND/OR THE TOP OF CURB RAMP AS APPLICABLE. TURNING SPACES SHALL BE PERMITTED TO OVERLAP CLEAR SPACES.
- WHERE THERE ARE NO VERTICAL CONSTRAINTS AT THE BACK OF SIDEWALK, (E.G., VERTICAL CURB, BUILDINGS, FENCES) THE TURNING SPACE DIMENSIONS SHALL BE 4.00' x 4.00' MINIMUM. WHERE THE TURNING SPACE IS CONSTRAINED AT THE BACK OF SIDEWALK, THE TURNING SPACE SHALL BE 4.00' x 5.00' MINIMUM. THE 5.00' DIMENSION SHALL BE PROVIDED PERPENDICULAR TO THE CONSTRAINT.
- TURNING SPACE MAXIMUM CROSS SLOPE IS 2% IN ANY DIRECTION.
- BEYOND THE BOTTOM GRADE BREAK, A CLEAR SPACE OF 4.00' x 4.00' MINIMUM SHALL BE PROVIDED WITHIN THE WIDTH OF THE PEDESTRIAN CROSSWALK, AND OUTSIDE THE PARALLEL VEHICLE TRAVEL LANE. THE CLEAR SPACE MAY OVERLAP TURNING SPACES, DETECTABLE WARNING SURFACES, AND DROP CURBS.

DETECTABLE WARNING DEVICE NOTES:

- DETECTABLE WARNING DEVICES (DWD) SHALL BE PROVIDED AT THE FOLLOWING LOCATIONS ON PEDESTRIAN ACCESS ROUTES:
 - CURB RAMPS AT PEDESTRIAN CROSSINGS.
 - PEDESTRIAN REFUGE ISLANDS (WHERE THE LENGTH OF THE PEDESTRIAN ACCESS ROUTE ACROSS THE REFUGE ISLAND IS GREATER THAN OR EQUAL TO 6.0'). SEE NHDOT'S SIDEWALK CURB RAMP DETAILS SHEET 8 OF 9.
 - PEDESTRIAN AT-GRADE RAIL CROSSINGS NOT LOCATED WITHIN A STREET OR HIGHWAY.
 - DRIVEWAY CROSSINGS WITH NHDOT APPROVED AND MAINTAINED SIGNALS, YIELD OR STOP CONTROL. DETECTABLE WARNING DEVICES SHALL NOT BE PROVIDED AT CROSSINGS OF UNCONTROLLED DRIVEWAY APRONS.
- SOME DETECTABLE WARNING PRODUCTS REQUIRE A CONCRETE BORDER FOR PROPER INSTALLATION. IF REQUIRED, THE BORDER SHALL NOT EXCEED 2" IN WIDTH OR 6" ALONG ROADWAY EDGE/CURB. THE BORDER DIMENSION SHALL BE MEASURED FROM THE INSIDE EDGE OF THE RADIUS.
- THE DETAILS PROVIDED ARE NOT DRAWN TO SCALE. THE QUANTITY OF DOMES DEPICTED ON THE DETECTABLE WARNING DEVICE DETAIL IS FOR ILLUSTRATION ONLY. THE SIZE OF THE DETECTABLE WARNING FIELD SHALL BE 2.00' MINIMUM IN THE DIRECTION OF TRAVEL AND SHALL EXTEND THE FULL WIDTH OF THE CURB RAMP OR FLUSH SURFACE, EXCLUDING ANY FLARED SIDES. THE WIDTH OF THE DETECTABLE WARNING FIELD INCLUDES A CONCRETE BORDER, IF PROVIDED. PLACEMENT AND ORIENTATION SHALL BE IN COMPLIANCE WITH THE DETAILS.
- ON SLOPES OF 5% OR GREATER, THE ROWS OF DOMES SHALL BE ALIGNED TO BE PERPENDICULAR OR RADIAL TO THE LOWER GRADE BREAK ON THE RAMP RUN. WHERE DOMES ARE ARRAYED RADIALY THEY MAY DIFFER IN DOME DIAMETER AND CENTER-TO-CENTER SPACING WITHIN THE RANGES SPECIFIED ON NHDOT'S SIDEWALK CURB RAMP DETAILS SHEET 9 OF 9. ON SLOPES LESS THAN 5%, DOME ORIENTATION IS LESS CRITICAL AND MAY DIFFER FROM PERPENDICULAR OR RADIAL ALIGNMENT TO THE GRADE BREAK.
- THE DETECTABLE WARNING SURFACES SHALL CONTRAST VISUALLY WITH ADJACENT GUTTER, STREET OR HIGHWAY, OR PEDESTRIAN ACCESS ROUTE SURFACE.
- DETECTABLE WARNING PANELS SHALL BE CAST IRON WITH NO SURFACE COATING AND SHALL BE ALLOWED TO TRANSITION TO THEIR NATURAL PATINA.

DEFINITION OF TERMS:

LANDING: A 4.00' x 4.00' CLEAR SPACE WITH A 2% SLOPE OR LESS IN ALL DIRECTIONS.

MAXIMUM EXTENT FEASIBLE: ALL CHANGES THAT ARE POSSIBLE ARE MADE TO COMPLY WITH ACCESSIBILITY STANDARDS.

PEDESTRIAN ACCESS ROUTE (PAR): A CONTINUOUS AND UNOBSTRUCTED PATH OF TRAVEL PROVIDED FOR PEDESTRIANS WITH DISABILITIES WITHIN OR COINCIDING WITH A PEDESTRIAN CIRCULATION PATH. PAR SHALL BE 4'W MIN.(EXCLUDING CURBING), 2% MAX. CROSS SLOPE AND 1/4" OR LESS VERTICAL DISCONTINUITY.

TECHNICAL INFESABILITY: EXISTING PHYSICAL OR SITE CONSTRAINTS THAT PROHIBIT MODIFICATIONS OR ADDITIONS OF ELEMENTS, SPACES OR FEATURES TO COMPLY WITH MINIMUM ACCESSIBILITY REQUIREMENTS.

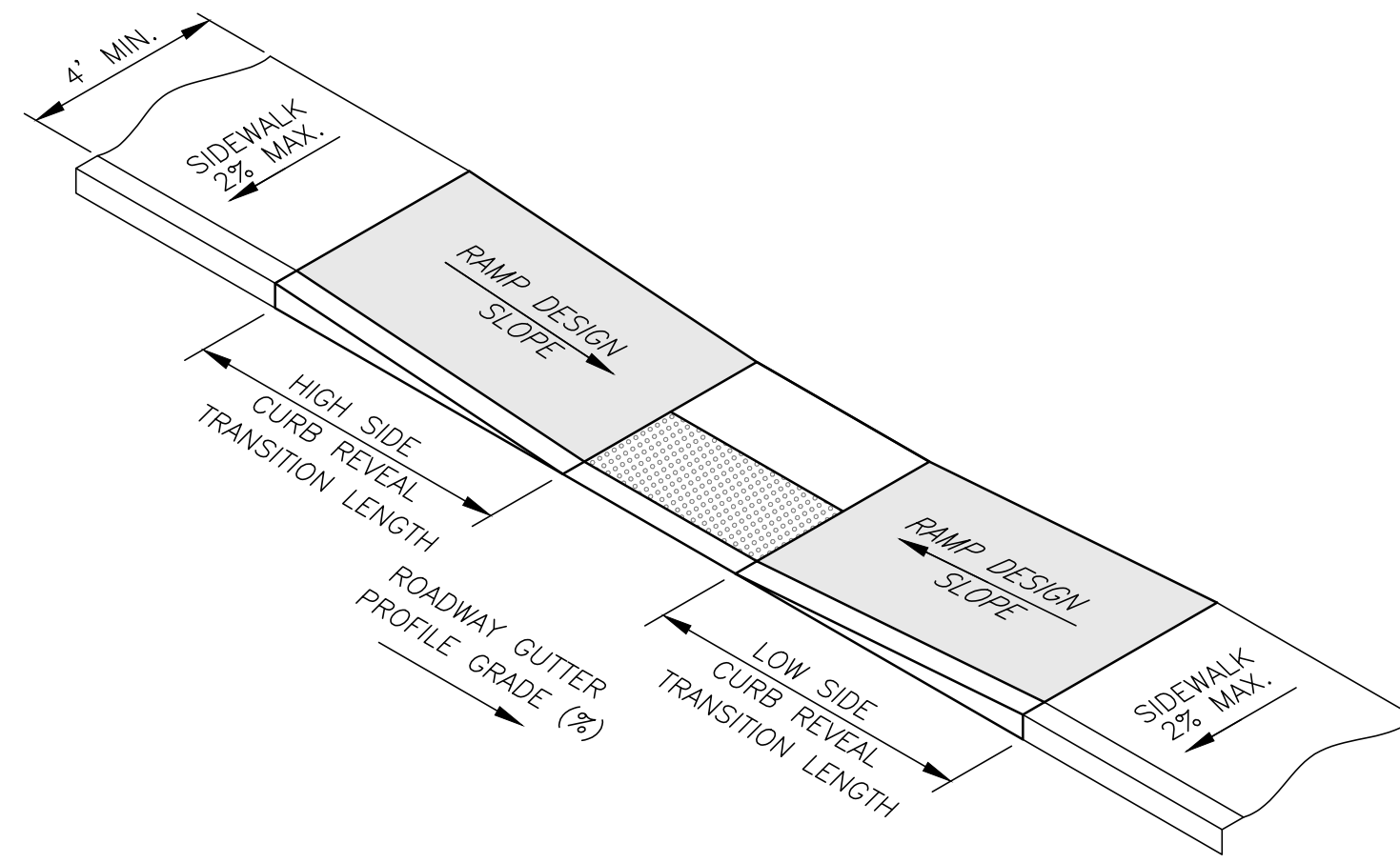
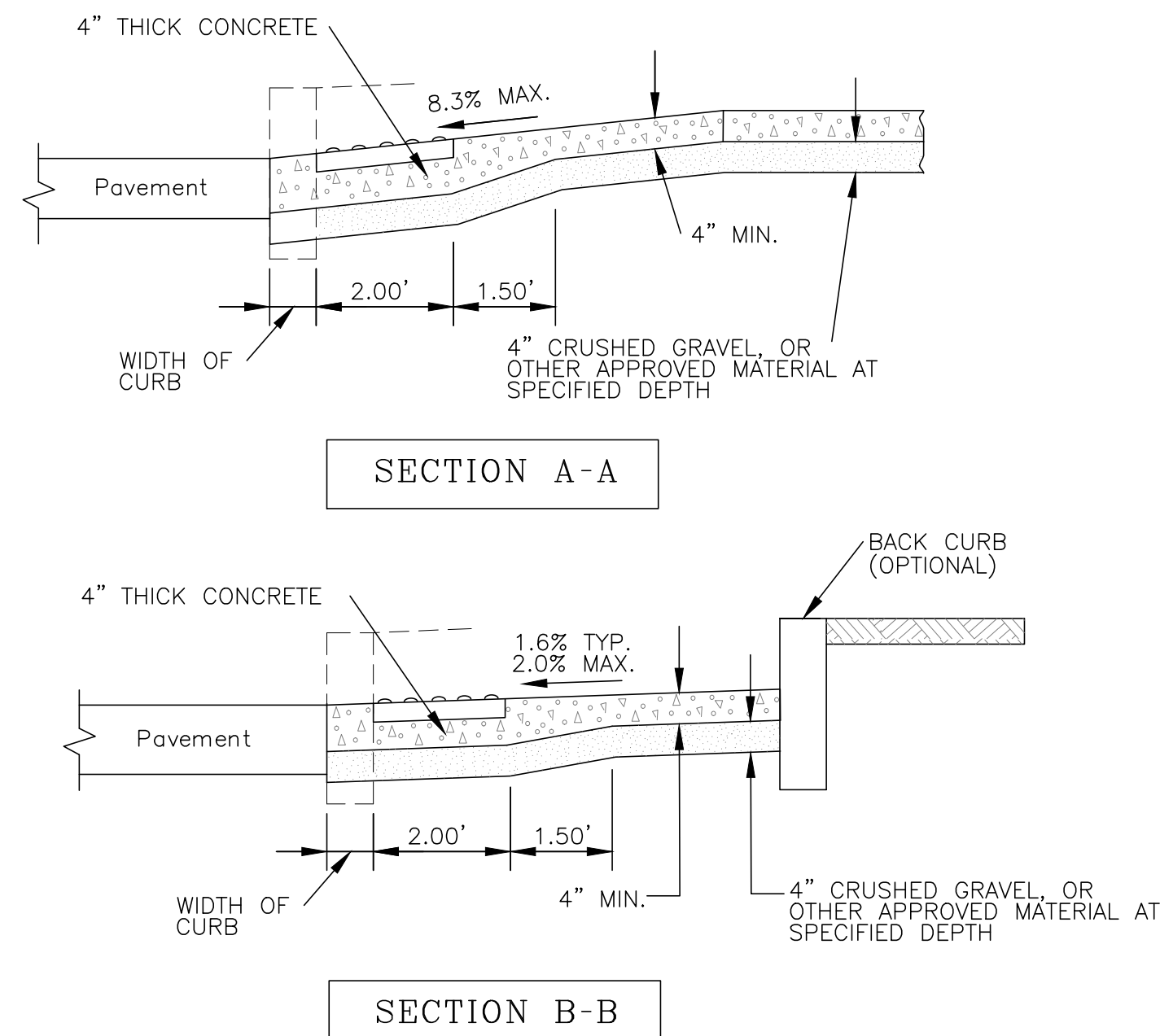

TYPICAL CURB TRANSITION LENGTH TABLE								
CURB REVEAL (INCHES)	ROADWAY PROFILE GRADE (%)	Minimum Transition Length Required (FT)						
		7	6	5	4	3	2	1
Low Side Transition Length	-10%	5.0	5.0	5.0	5.0	5.0	5.0	5.0
	-9%	5.0	5.0	5.0	5.0	5.0	5.0	5.0
	-8%	5.0	5.0	5.0	5.0	5.0	5.0	5.0
	-7%	5.0	5.0	5.0	5.0	5.0	5.0	5.0
	-6%	5.0	5.0	5.0	5.0	5.0	5.0	5.0
	-5%	5.0	5.0	5.0	5.0	5.0	5.0	5.0
	-4%	5.1	5.0	5.0	5.0	5.0	5.0	5.0
	-3%	5.6	5.0	5.0	5.0	5.0	5.0	5.0
	-2%	6.1	5.3	5.0	5.0	5.0	5.0	5.0
	-1%	6.9	5.9	5.0	5.0	5.0	5.0	5.0
High Side Transition Length	0%	7.8	6.7	5.6	5.0	5.0	5.0	5.0
	1%	9.0	7.7	6.4	5.1	5.0	5.0	5.0
	2%	10.6	9.1	7.6	6.1	5.0	5.0	5.0
	3%	13.0	11.1	9.3	7.4	5.6	5.0	5.0
	4%	15.0	14.3	11.9	9.5	7.1	5.0	5.0
	5%	15.0	15.0	15.0	13.3	10.0	6.8	5.0
	6%	15.0	15.0	15.0	15.0	15.0	11.3	5.3
	7%	15.0	15.0	15.0	15.0	15.0	15.0	15.0
	8%	15.0	15.0	15.0	15.0	15.0	15.0	15.0
	9%	15.0	15.0	15.0	15.0	15.0	15.0	15.0
10%	15.0	15.0	15.0	15.0	15.0	15.0	15.0	

THIS TABLE REPRESENTS THE MINIMUM LENGTH OF CURB RAMP TRANSITION BASED ON THE EXISTING ROADWAY PROFILE GRADE AND THE CURB REVEAL AT FULL HEIGHT ALONG THE SIDEWALK. THE MINIMUM TRANSITION LENGTH REQUIRED IS BASED ON 7.5% SLOPE AND INDICATED CURB REVEAL.

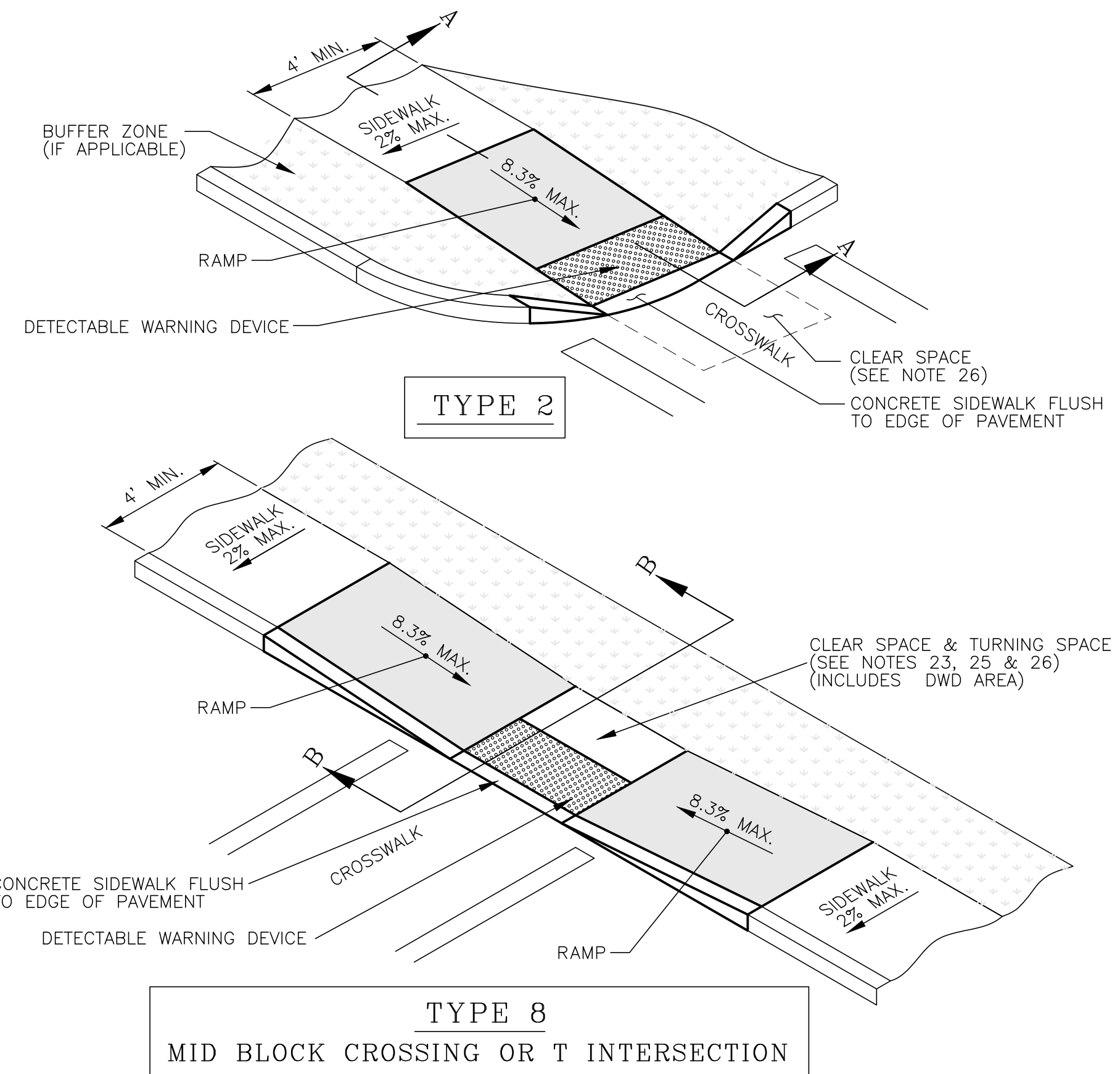

designed by:	JUB/STF	date:	April 2023
drawn by:	A/RS/STF	project no.:	1030
approved by:	JUB	file name:	1030-Details.dwg
scale:		revision:	1
date:	4/3/2023	no.:	1
by:	JUB	no.:	1

Issued for Bidding

4/3/2023

Portland, ME 207/541-4223
Manchester, NH 603/627-0708
Portsmouth, NH 603/431-6196

CMA ENGINEERS
CIVIL/ENVIRONMENTAL/STRUCTURAL

cm a e n g i n e e r s . c o m

Town of Exeter, New Hampshire
Public Works Department
Kingston Road TAP Project
Exeter 40436, X-A004(406)
Sidewalk Curb Ramps with Detectable Warnings

drawing no. D-2

sheet: 7 of 42

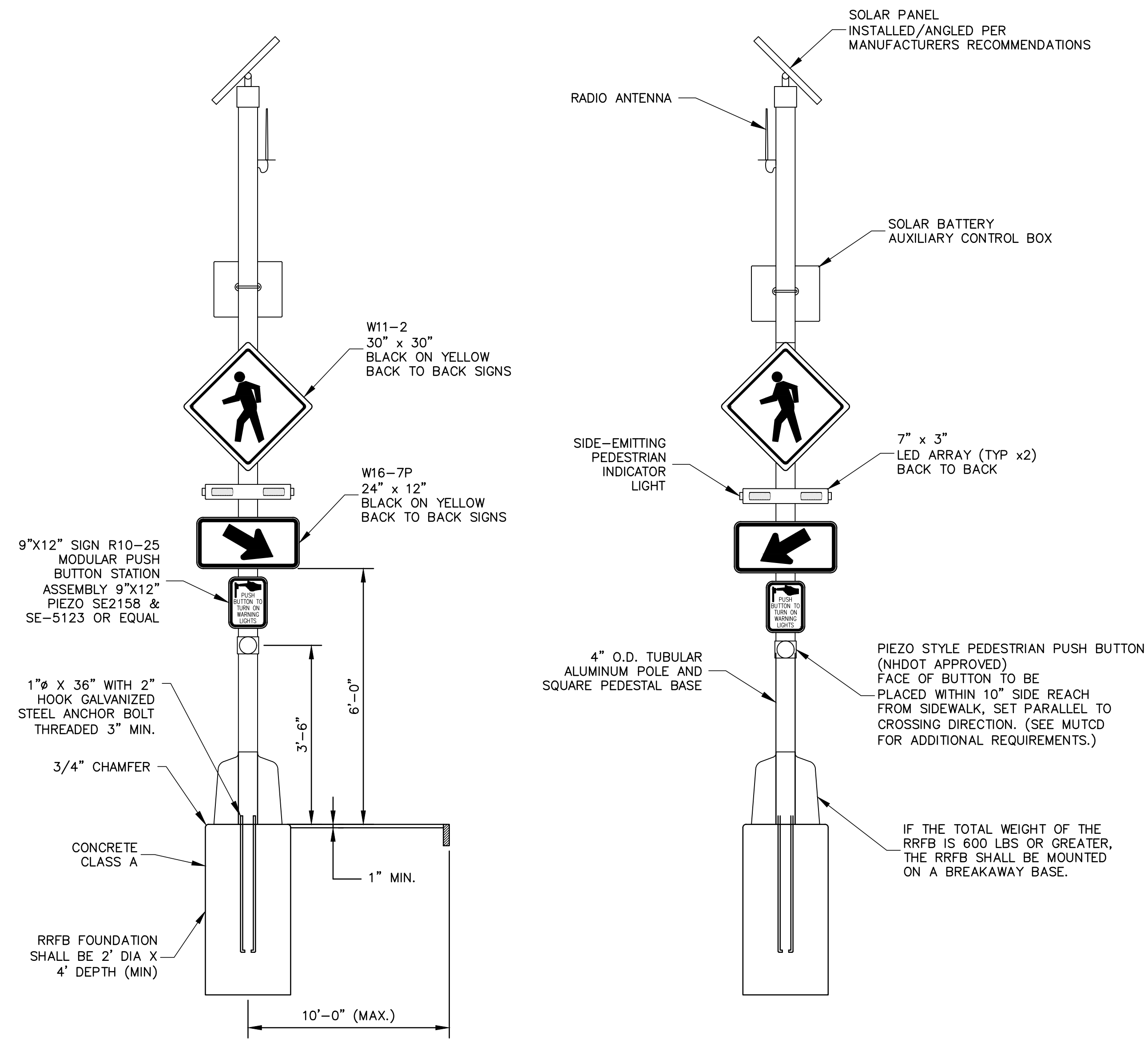

NOTES:

1. SHOP DRAWING REVIEW REQUIRED PRIOR TO ORDERING EQUIPMENT OR INSTALLING BASES.
2. ALL POLES, BASES, AND WIRE TO BE FURNISHED AND INSTALLED BY THE CONTRACTOR.
3. CONCRETE BASES SHALL BE INCIDENTAL TO THE RRFB ASSEMBLY INCLUDING ALL LABOR, EQUIPMENT AND MATERIALS REQUIRED FOR A COMPLETE INSTALLATION.
4. ANCHOR BOLTS, GROUND ROD & GROUND WIRE TO BE FURNISHED AND INSTALLED BY THE CONTRACTOR.
5. BOLT CIRCLE DIAMETER SHALL BE VERIFIED WITH THE MANUFACTURER.
6. REINFORCEMENT SHALL CONFORM TO SECTION 544 OF THE STANDARD SPECIFICATIONS.
7. ANY ANCHOR BOLTS DAMAGED DURING INSTALLATION SHALL BE REPAIRED OR REPLACED AS DIRECTED BY THE ENGINEER.
8. UPON INSTALLATION, ANCHOR BOLT THREADS SHALL BE CLEANED WITH A WIRE BRUSH.
9. ALL SIGNS, FLASHING LIGHTS, SOLAR ELECTRICAL PANELS, WIRING, CONNECTIONS, PUSH BUTTONS, RADIO INTERCONNECTIONS, SUPPORT POLES, CONCRETE FOUNDATIONS, EXCAVATION, AND OTHER ASSOCIATED EQUIPMENT AND CONSTRUCTION PROCEDURES FOR A COMPLETE AND FUNCTIONAL SIGN ASSEMBLY SHALL BE PAID FOR UNDER ITEM 616.261 RECTANGULAR RAPID FLASHING BEACON ASSEMBLY, PER PAIR OR RRFBS.
11. INSTALL W11-2 WITH APPROPRIATE ADVANCE WARNING PLAQUE PRIOR TO CROSSING WHEN REQUIRED.
12. SEE PLANS LOCATED ELSEWHERE IN THE PROPOSAL FOR PROPOSED LOCATION OF RRFB AND ADVANCE WARNING SIGNAGE.
13. THE TOTAL WEIGHT OF RRFB SHALL NOT EXCEED 600 LBS. TO MEET BREAKAWAY SUPPORT REQUIREMENTS.
14. INSTALL W11-2 WITH W16-2aP SIGNS (250') PRIOR TO CROSSING.

Rectangular Rapid Flashing Beacon Assembly Detail

Not to Scale

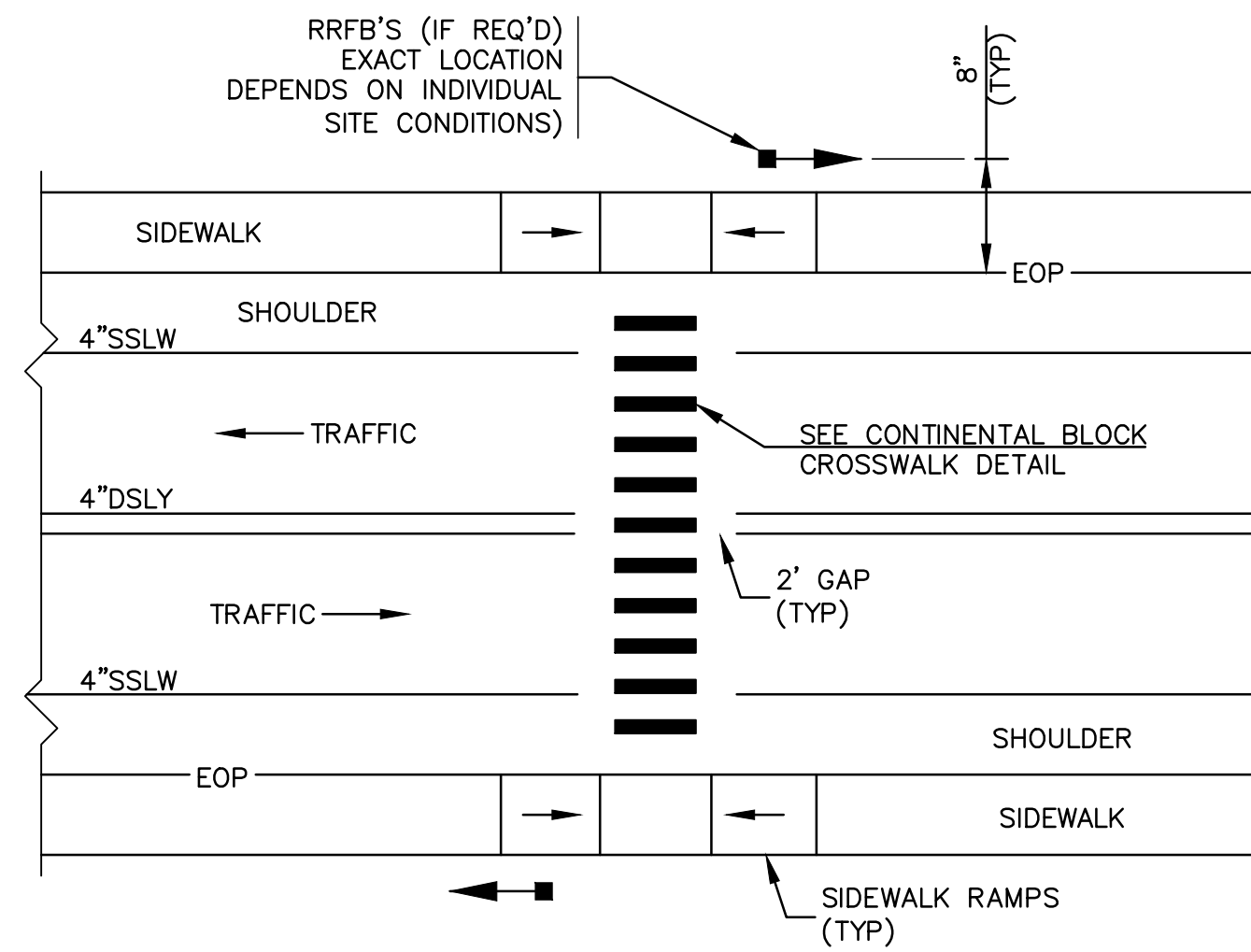

Continental Block Crosswalk Marking For a Mid-Block or Non-Stop Condition

Not to Scale
(T) THERMOPLASTIC

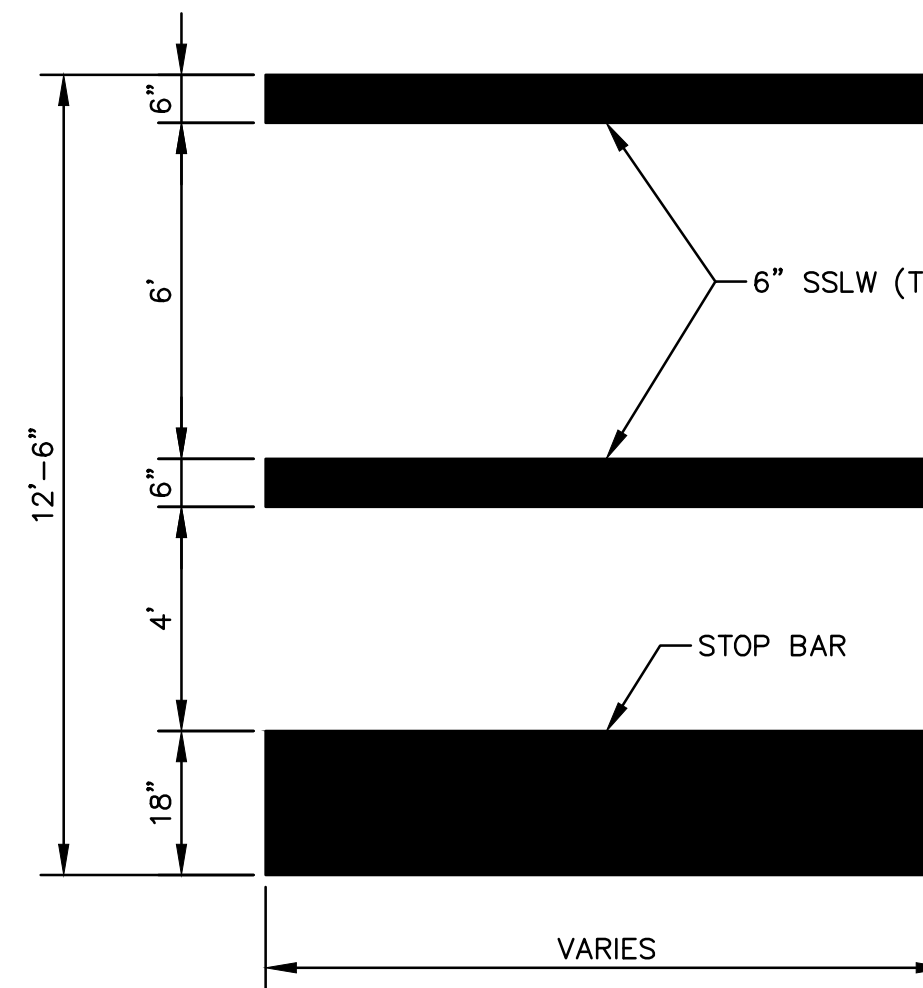

Standard Crosswalk Detail

Not to Scale

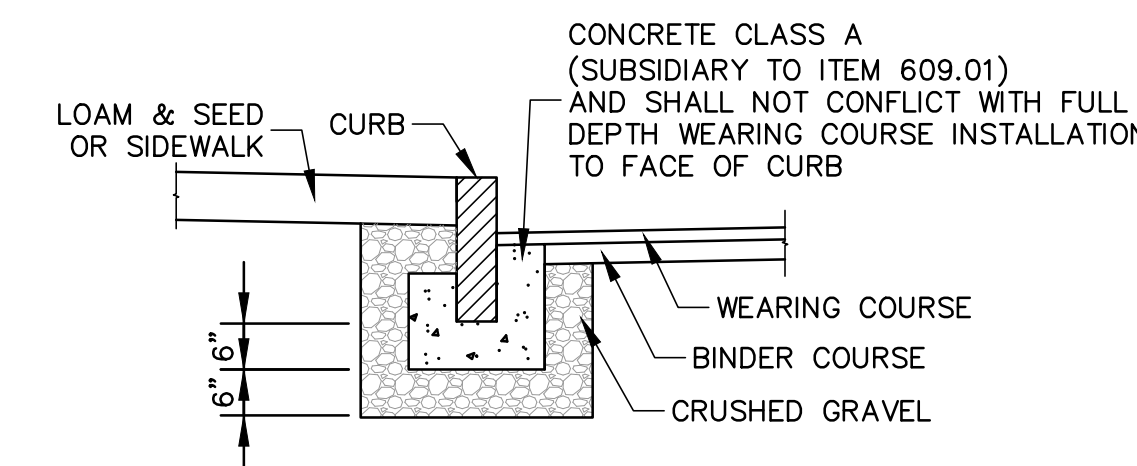

Concrete Curb Backing Detail

Not To Scale

NOTES:

1. STOP LINES ARE 18" WIDE SSLW (T).
2. TRANSVERSE CROSSWALK LINES SHALL BE THERMOPLASTIC, NOT LESS THAN 6" WIDE AND NOT LESS THAN 6' APART.
3. SPACING FOR THE CONTINENTAL BLOCK MARKINGS SHALL BE UNIFORM FOR EACH INDIVIDUAL CROSSWALK BUT CAN BE MODIFIED FOR ONE CROSSWALK TO THE NEXT TO ELIMINATE A CROSSWALK MARKING DIRECTLY IN THE WHEELPATH.
4. CROSSINGS LOCATED AT A YIELD CONTROLLED SLIP RAMP SHALL USE CONTINENTAL BLOCK MARKINGS.

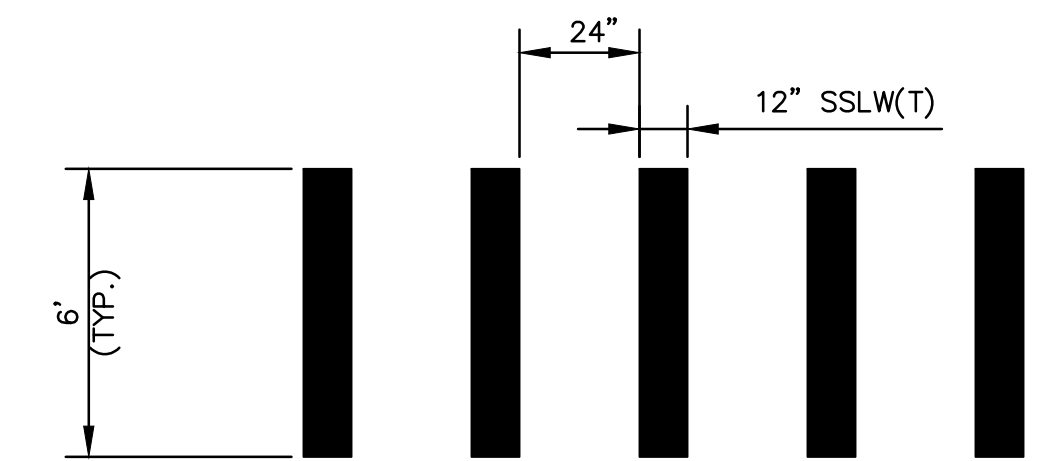

Continental Block Marking Detail

Not to Scale
(T) THERMOPLASTIC

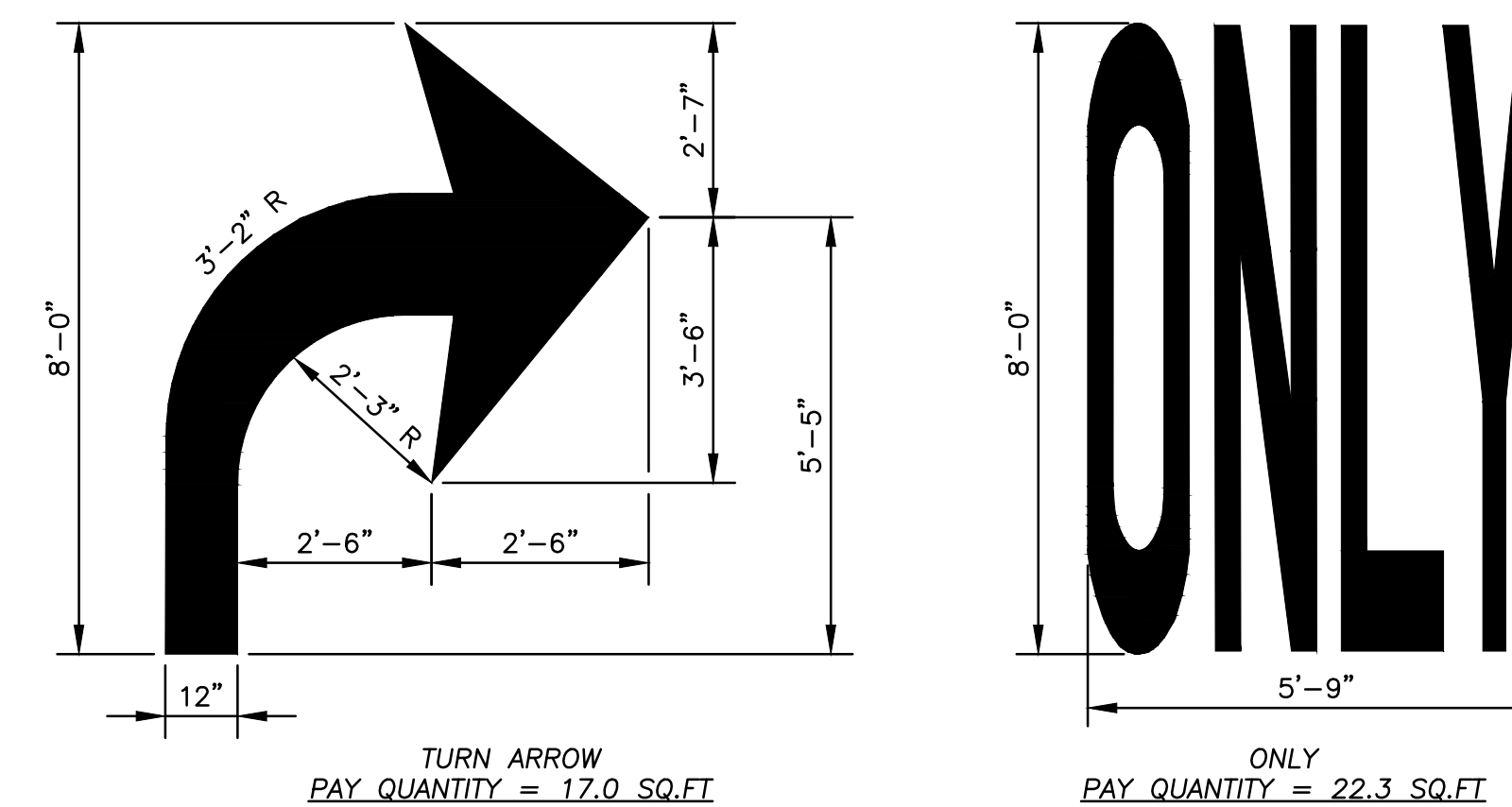

Pavement Marking Detail

Not to Scale

NOTES:

1. ALL WORDS AND SYMBOLS SHALL BE RETROREFLECTIVE WHITE AND SHALL CONFORM TO THE LATEST VERSION OF THE MUTCD.
2. MULTI-WORD MESSAGES SHALL READ "UP"; THAT IS, THE FIRST WORD SHALL BE NEAREST THE APPROACHING DRIVER.
3. THE WORD "ONLY" SHALL NOT BE USED WITH THROUGH OR COMBINATION ARROWS, AND SHALL NOT BE USED ADJACENT TO A BROKEN LANE LINE. A WORD/SYMBOL SHALL PRECEDE THE WORD "ONLY"
4. PERFORMED WORDS AND SYMBOLS SHALL BE PRE-CUT BY THE MANUFACTURER.

		CIVIL/ENVIRONMENTAL/STRUCTURAL Portsmouth, NH • Manchester, NH • Portland, ME 603/431-6196 • 603/627-0708 • 207/541-4223 c m a e n g i n e e r s . c o m
designed by: JUB/STF	drawn by: ATR/STF	approved by: JUB
date: April 2023	project no: 1030	file name: 1030-Details.dwg
Town of Exeter, New Hampshire Public Works Department Kingston Road TAP Project Exeter 40436, X-A004(406)		scale: drawing no. D-3
sheet: 8 of 42	no. 1	revision 1 date 4/3/2023 by JUB

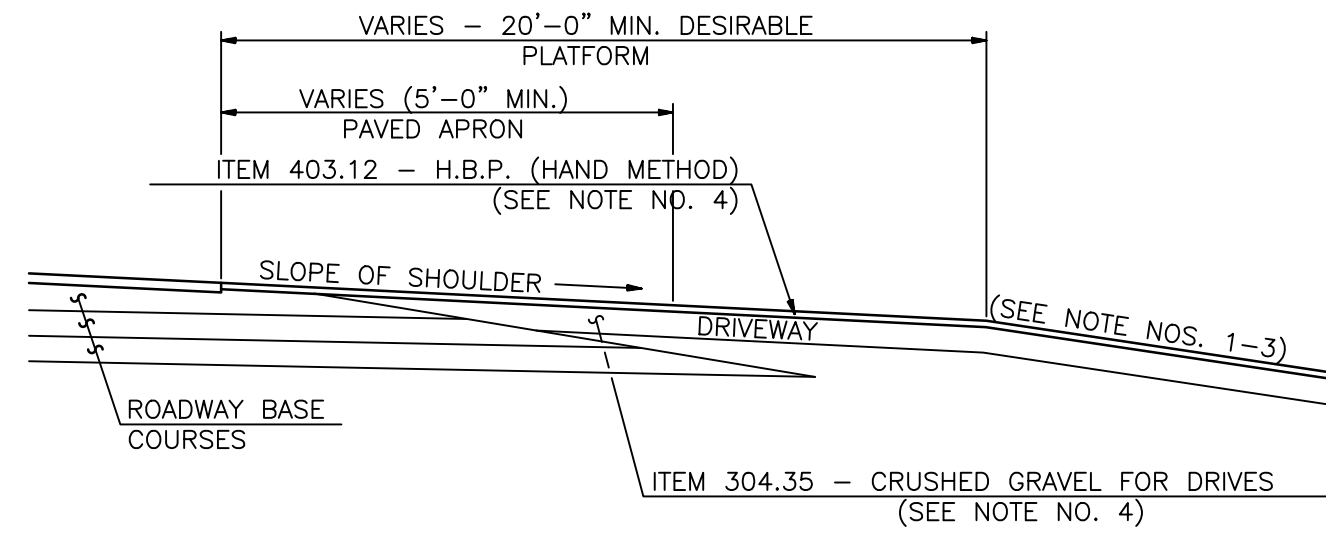

Typical Uncurbed Driveway in Fill Section

Not to Scale

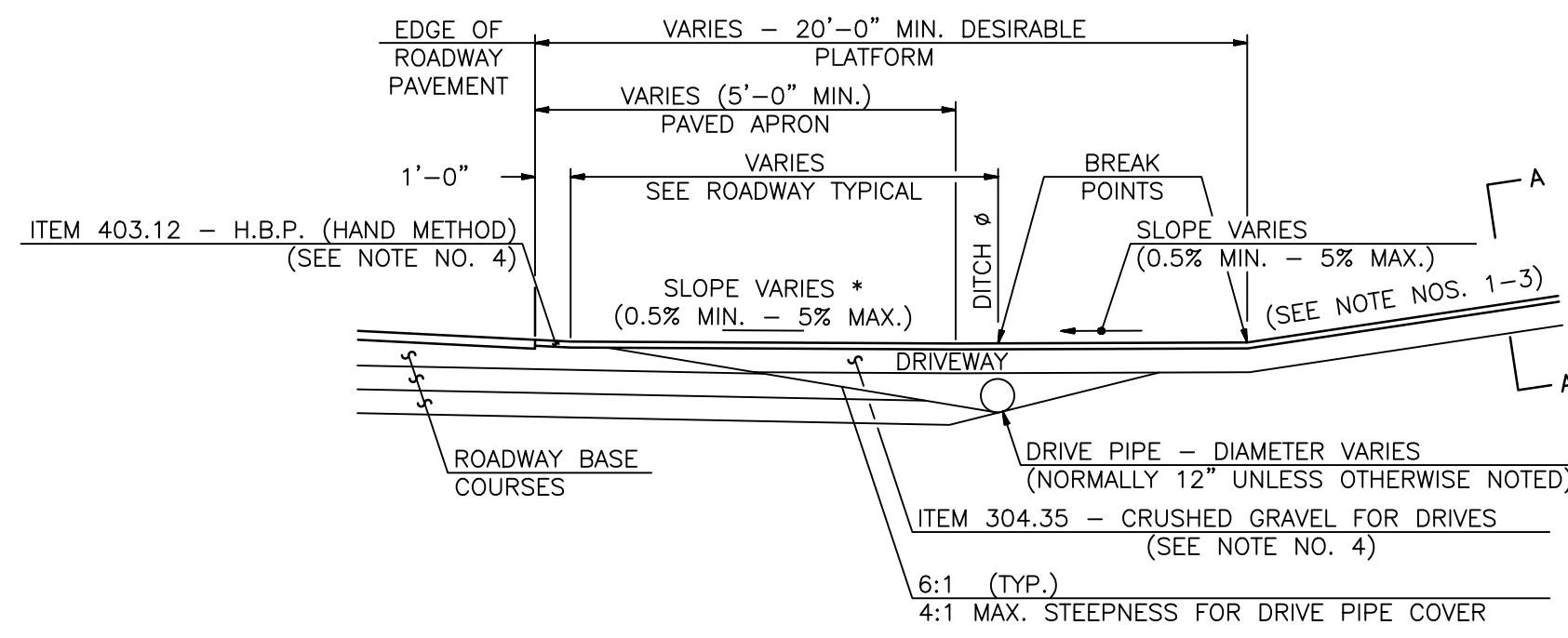

Typical Uncurbed Driveway in Cut Section

Not to Scale

DRIVEWAY NOTES:

- GRADES OF MAJOR ENTRANCES BEYOND THE PLATFORM SHALL NOT EXCEED 8%.
- GRADES OF OTHER DRIVES BEYOND THE PLATFORM SHALL NOT EXCEED 15%.
- THE ALGEBRAIC DIFFERENCE BETWEEN TWO ADJACENT GRADES SHALL NOT EXCEED 10%.
- PAVEMENT & BASE COURSE DEPTHS FOR RESIDENTIAL DRIVES SHALL BE 9" CRUSHED GRAVEL WITH 3.0" H.B.P. (HAND METHOD) TWO COURSES (1" OF 3/8" MIX, 2" OF 3/4" MIX).
- FOR UNPAVED DRIVES, THE PAVED APRON NORMALLY ENDS AT THE RADIUS TANGENT POINT.

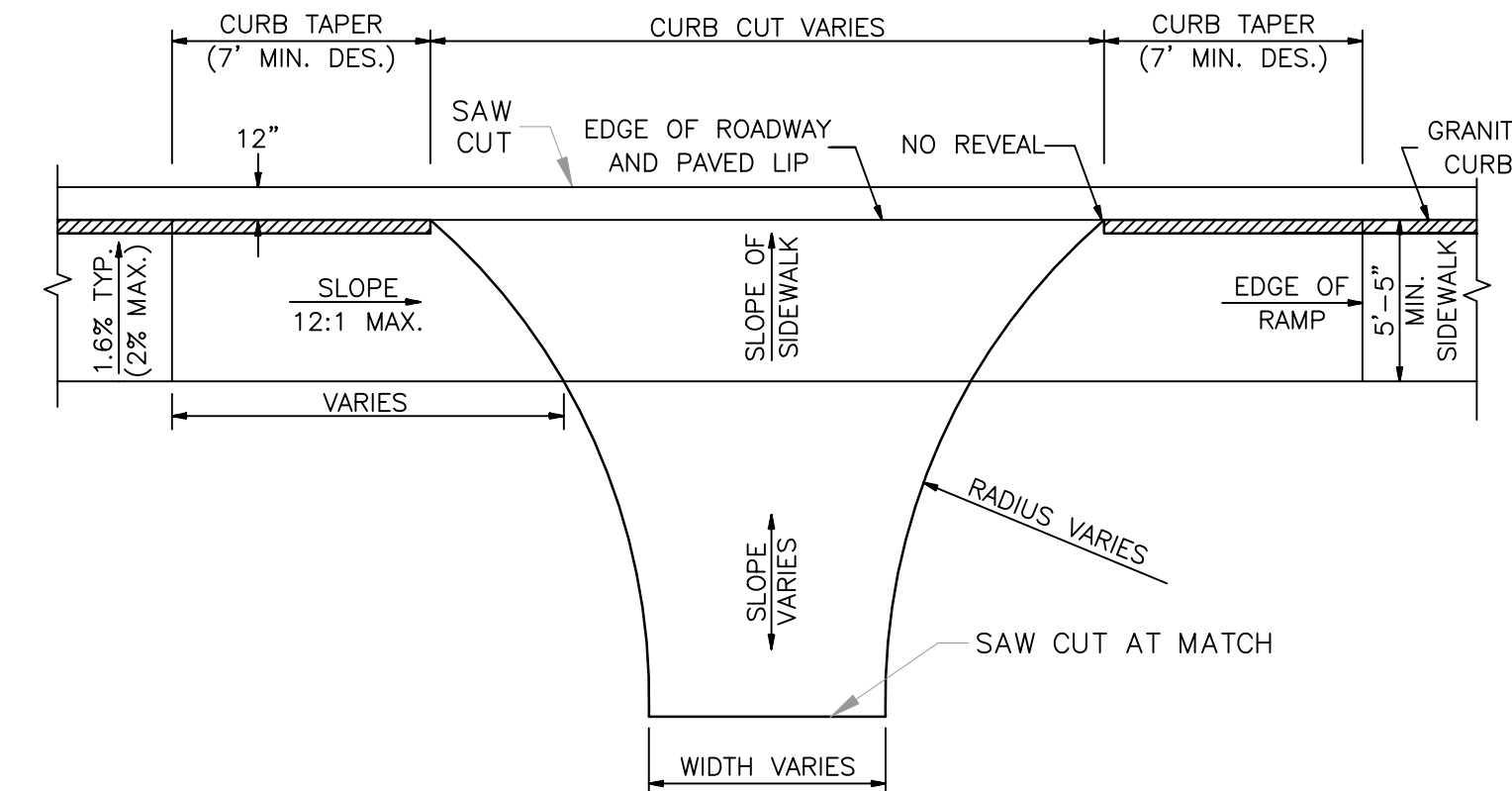

PLAN VIEW WITH SIDEWALK RAMP

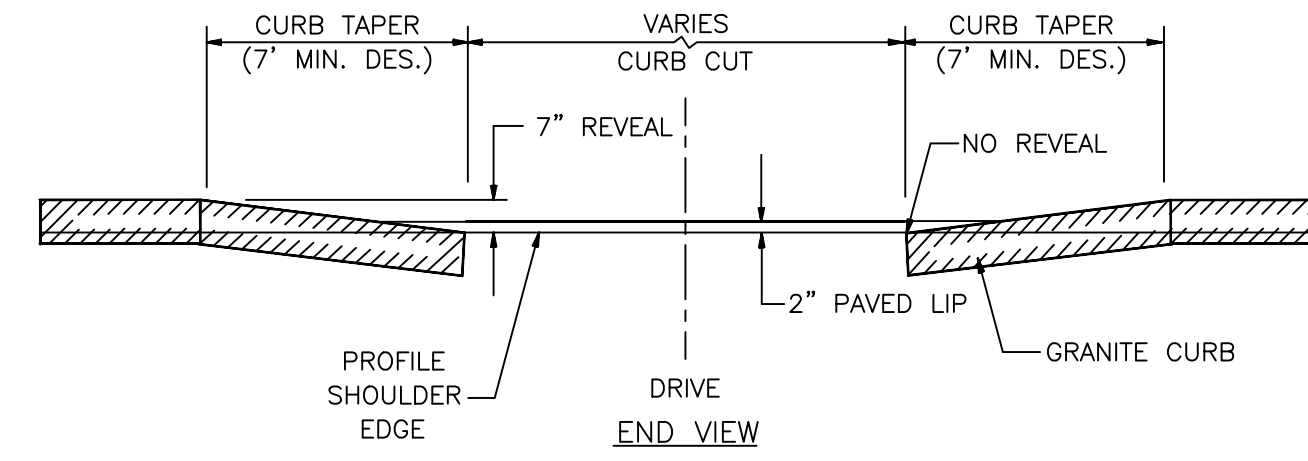

Driveway Detail

Not to Scale

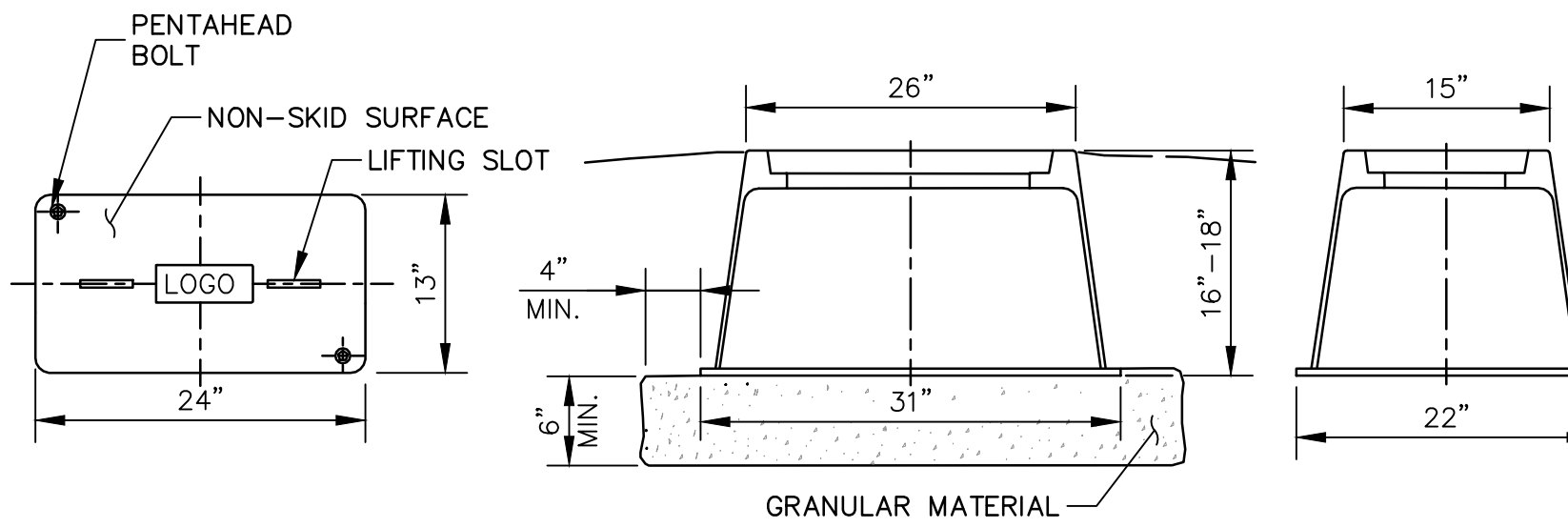

Molded Pull Boxes

Not to Scale

NHDOT CLASS "C" STONE (ITEM 585.3)
OVER 10 OZ NON-WOVEN
GEOTEXTILE (ITEM 593.421)

Storm Drain Pipe Installation

Not to Scale

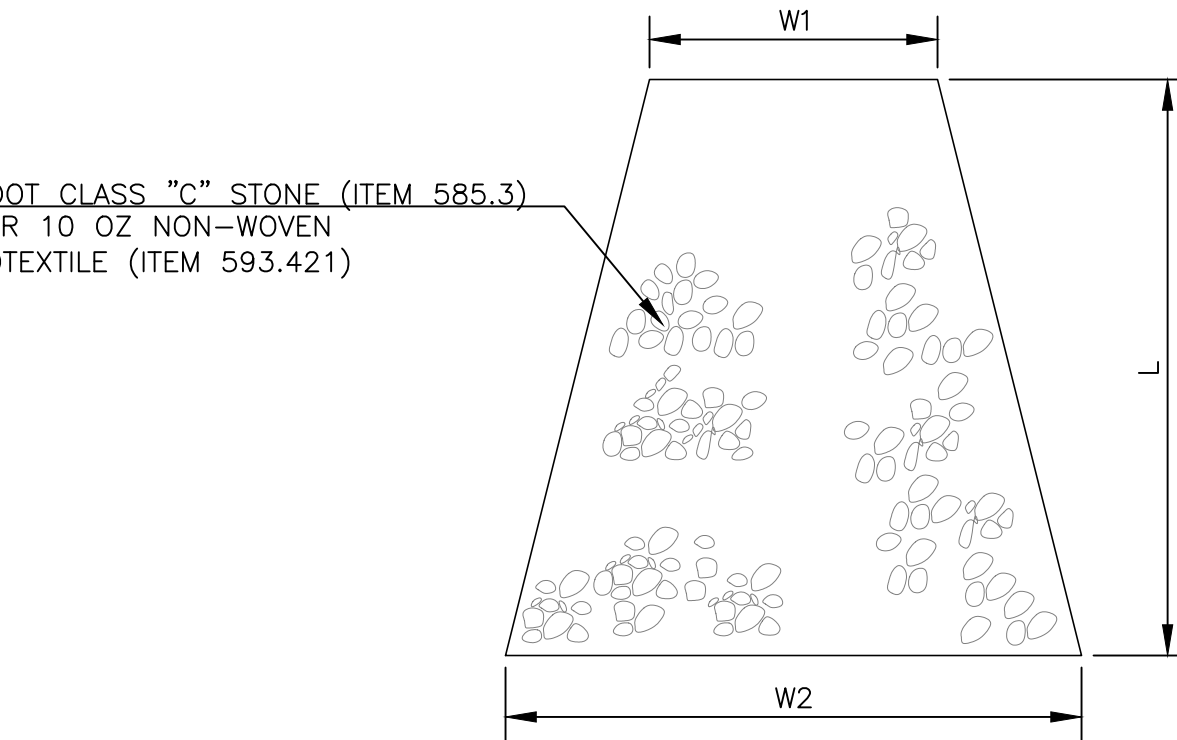

NOTE:

- STONE TO BE A MINIMUM OF 12" DEEP.
- CONTRACTOR RESPONSIBLE FOR REMOVING DEBRIS OR SEDIMENT WHICH ENTERS STONE PRIOR TO STABILIZATION.
- SEE DRAINAGE NOTES FOR REQUIRED DIMENSIONS.

Typical Culvert Outlet Protection

Not to Scale

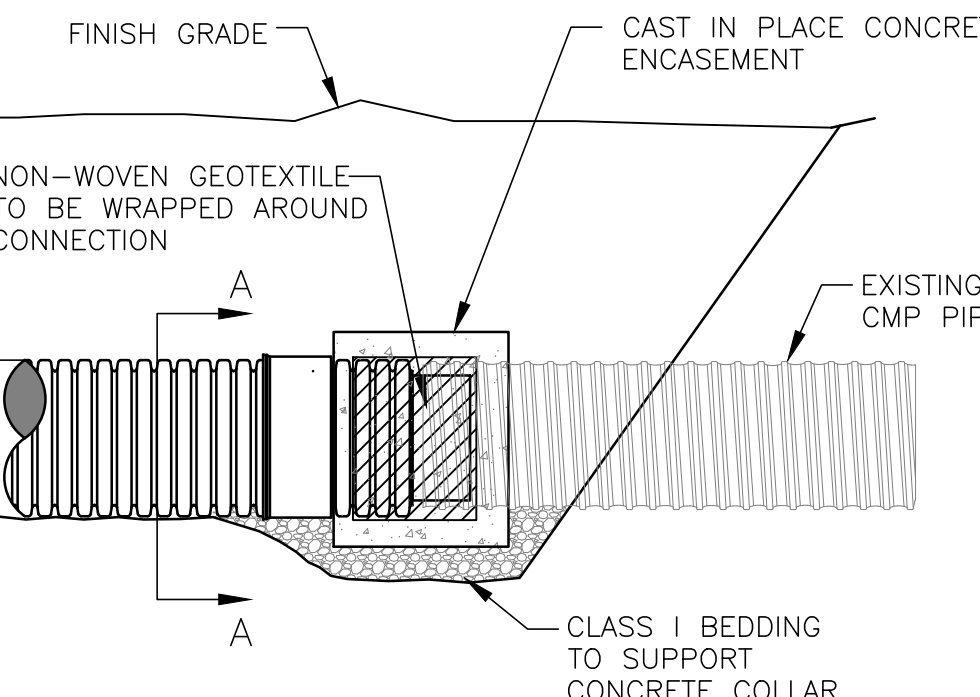
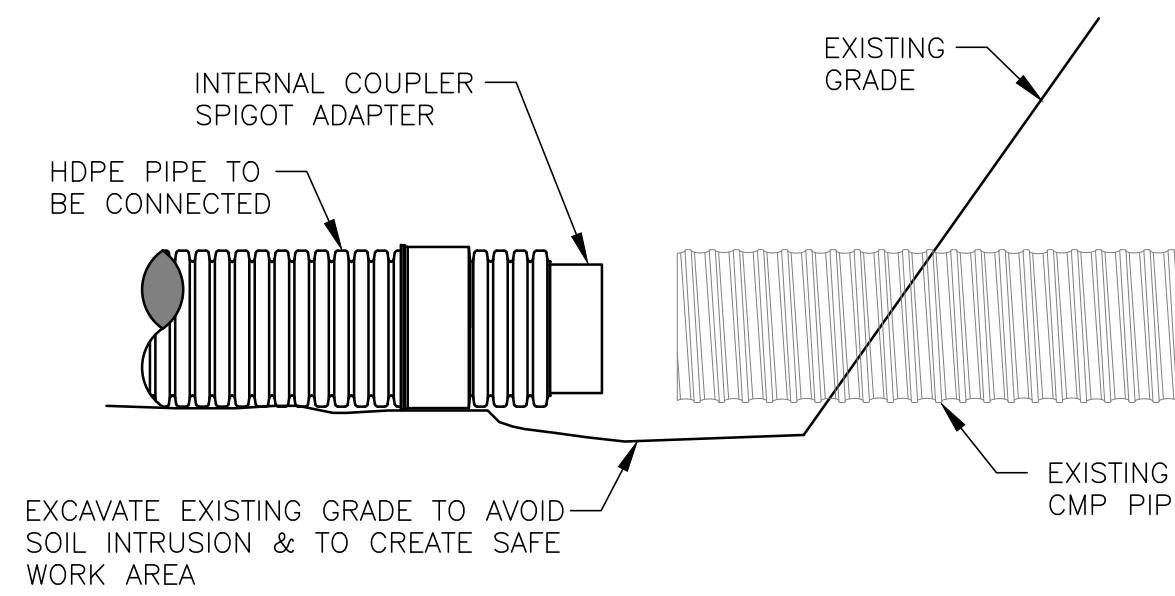

HDPE to CMP Connection (Geotextile Wrap)

Not to Scale

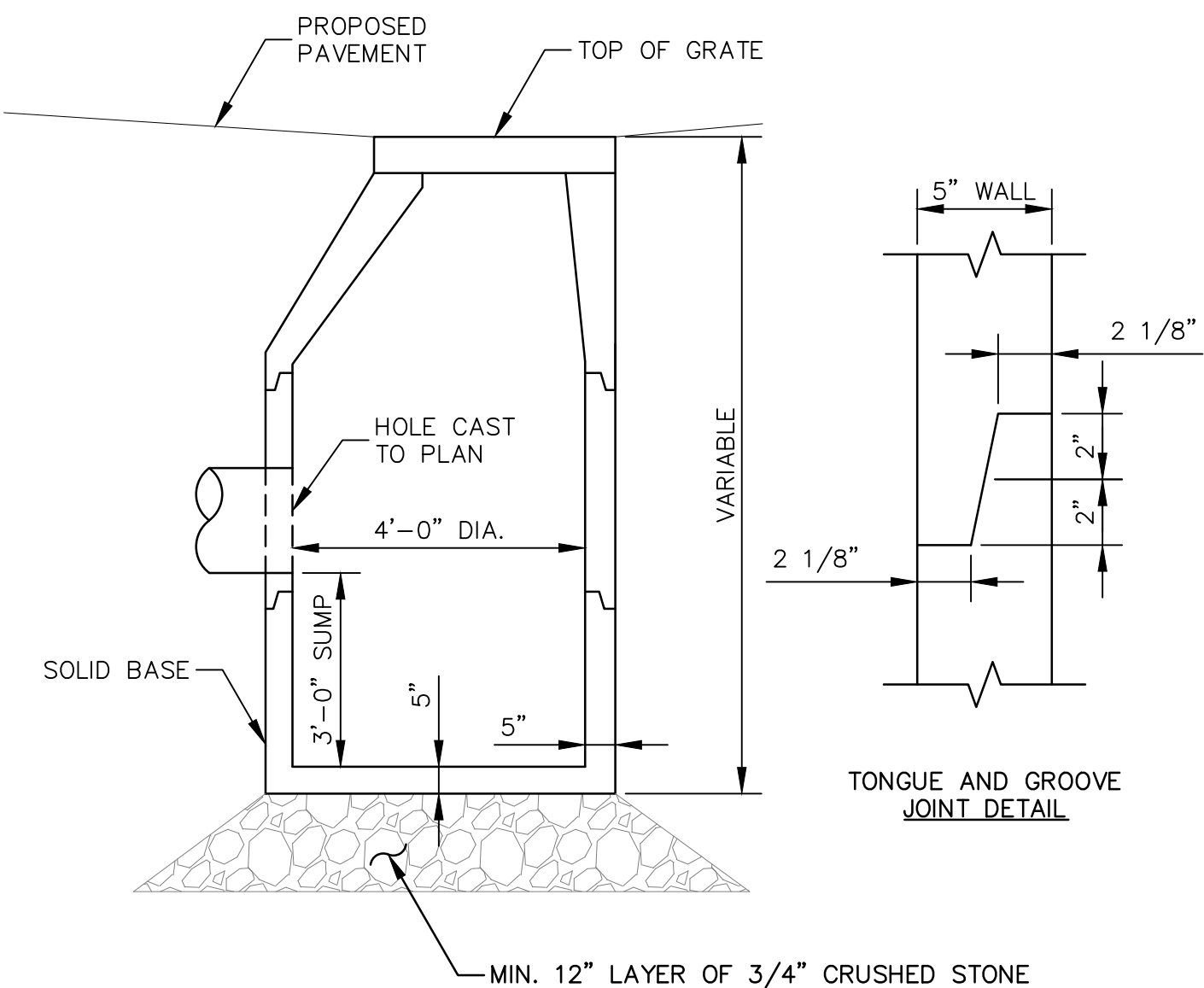

Catch Basin Detail

Not to Scale

NOTES:

- Horizontal joints between sections of precast concrete barrels shall be of a type approved by the Engineer, which shall, in general, depend for watertightness upon an elastomeric or mastic-like gasket.
- Pipe to manhole joints shall be only as approved by the Engineer and in general watertightness will depend upon either an approved non-shrinking mortar or elastomeric sealant.
- For bitumastic type joints, the amount of sealant shall be sufficient to fill at least 75% of the joint cavity. Approved bitumastic sealants include RAM-NEK, Kent seal No. 2, EZ or equal.
- All structures shall meet HL-93 Loading.
- The tongue or the groove of the joint of the wall, shall contain one line of circumferential reinforcement equal to 0.12 sq.in. per linear foot.
- Eccentric cones shall be used when depth to crown of shallowest pipe exceeds 30". Risers of 12", 3' and 4' can be used to reach the desired depth.
- Catch basin grates to be NHDOT Type B cast iron and all drain manhole covers shall be labeled "DRAIN"

NOTES:

- CONNECTION AND PIPE TO BE BACKFILLED PER ASTM D2321, LATEST EDITION.
- IN LIEU OF AN INTERNAL CYLINDER, AN HDPE WATERTIGHT REPAIR COUPLER CAN BE USED.
- INTERNAL CYLINDER ADAPTER IS NOT RECOMMENDED FOR DOWNSTREAM CONNECTIONS.
- HDPE TO CMP CONNECTIONS SHALL BE SUBSIDIARY TO ITEM 603.80212 12" PLASTIC PIPE (SMOOTH INTERIOR).

4/3/2023	JUB	by
		date
1		revision
		no.
		Issued for Bidding

CMA ENGINEERS
 CIVIL/ENVIRONMENTAL/STRUCTURAL
 Portsmouth, NH • Manchester, NH • Portland, ME
 603/431-6196 • 603/627-0708 • 207/541-4223
 c m a e n g i n e e r s . c o m

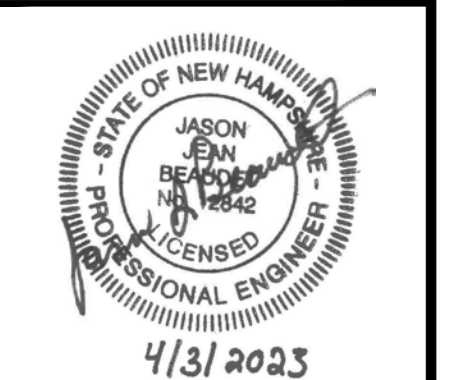

April 2023	JUB/STF	designed by:
1030	ATR/STF	drawn by:
1030-Details.dwg	JUB	approved by:
		scale:

Town of Exeter, New Hampshire
 Public Works Department
 Kingston Road TAP Project
 Exeter 40436, X-A004(406)
 Details

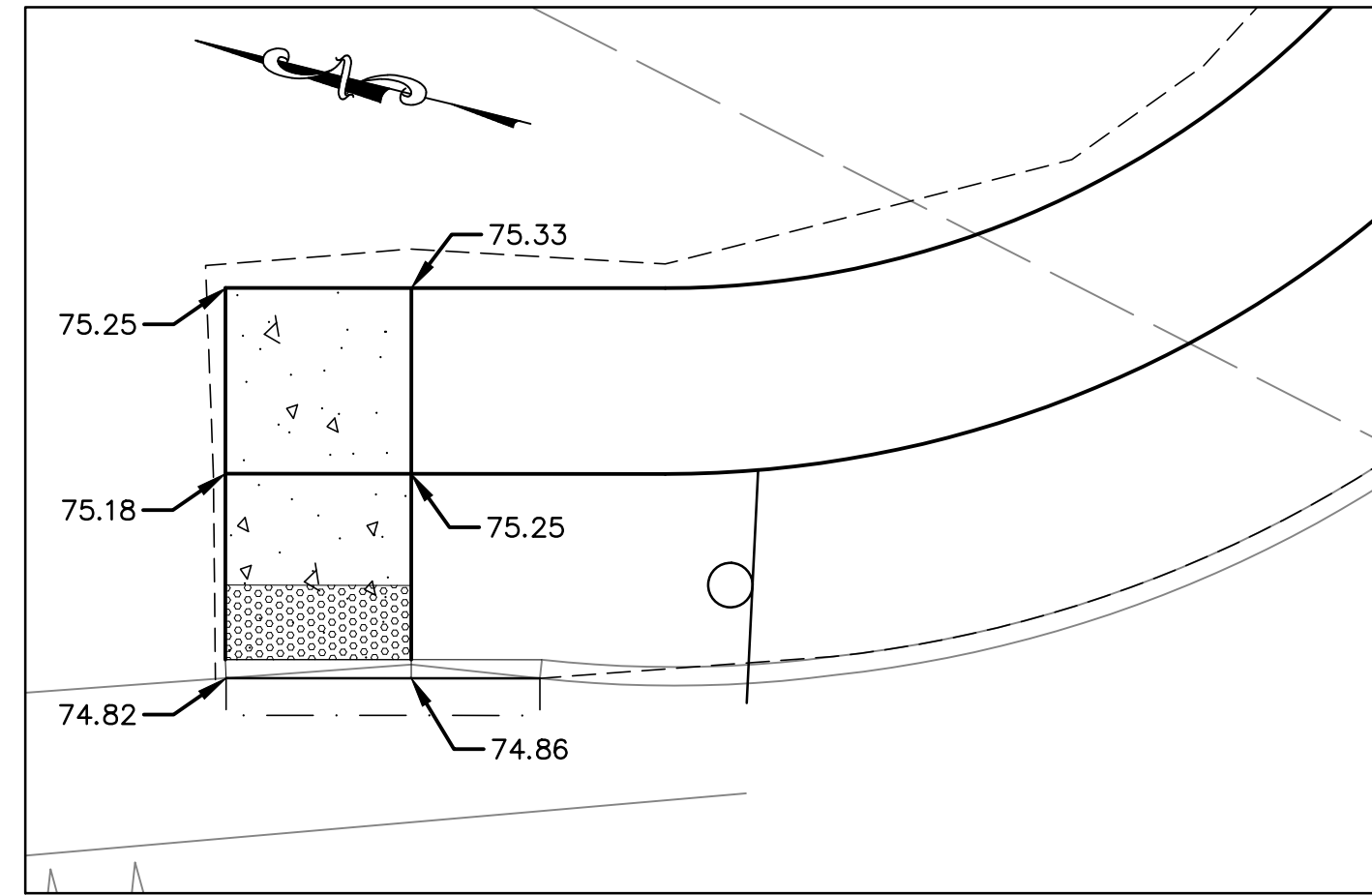

White Oak Drive Crossing

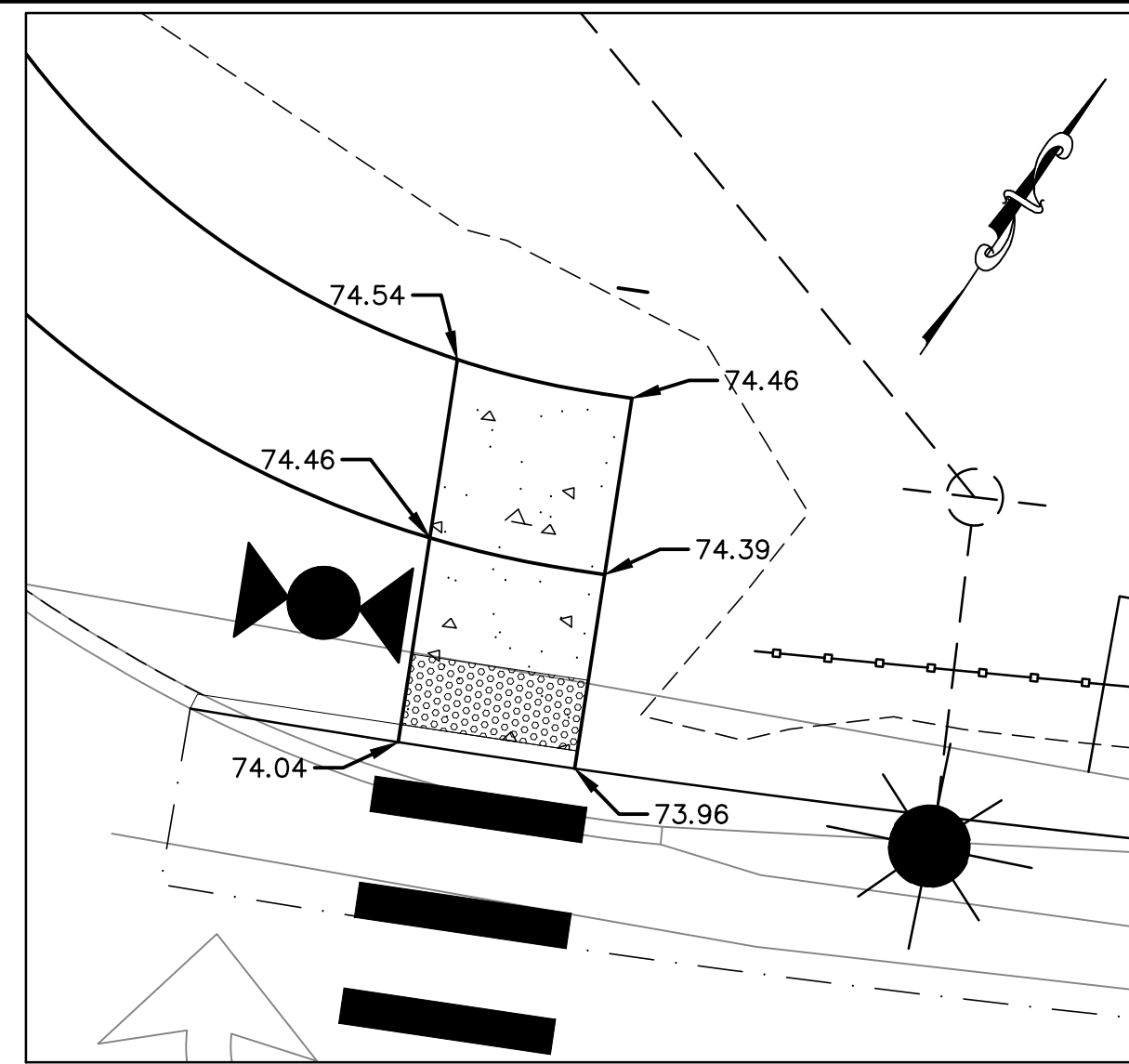

Kingston Road Crossing at White Oak Drive

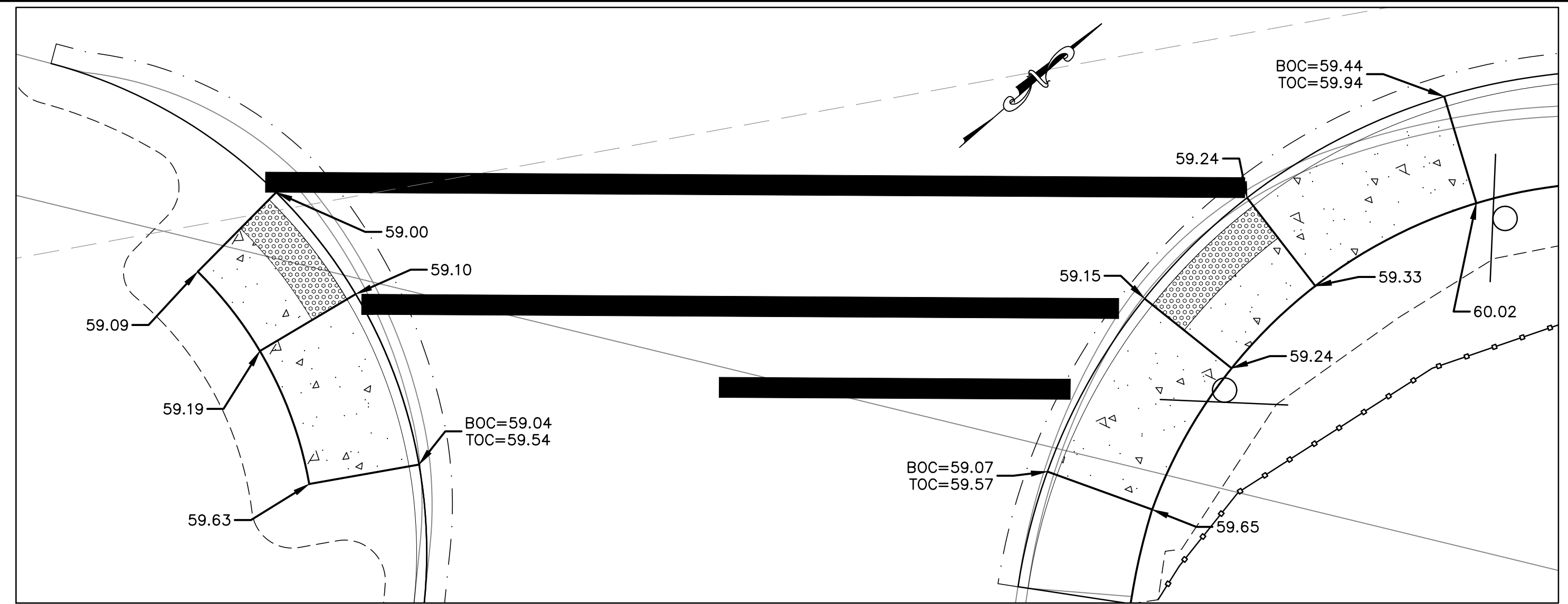

Tamarind Lane Crossing

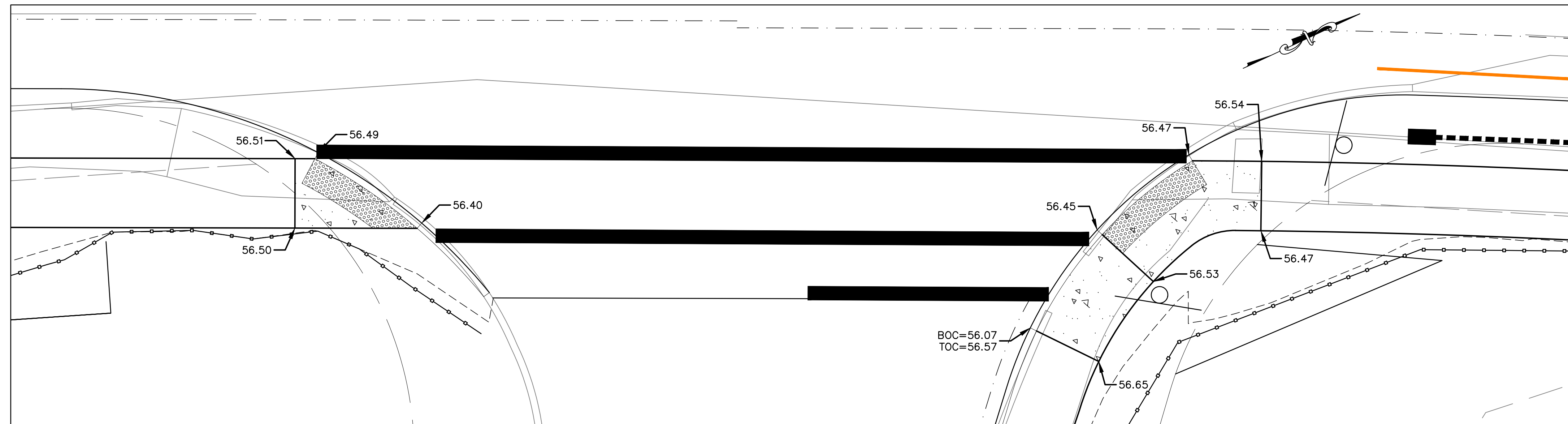

Greybird Farm Circle Crossing

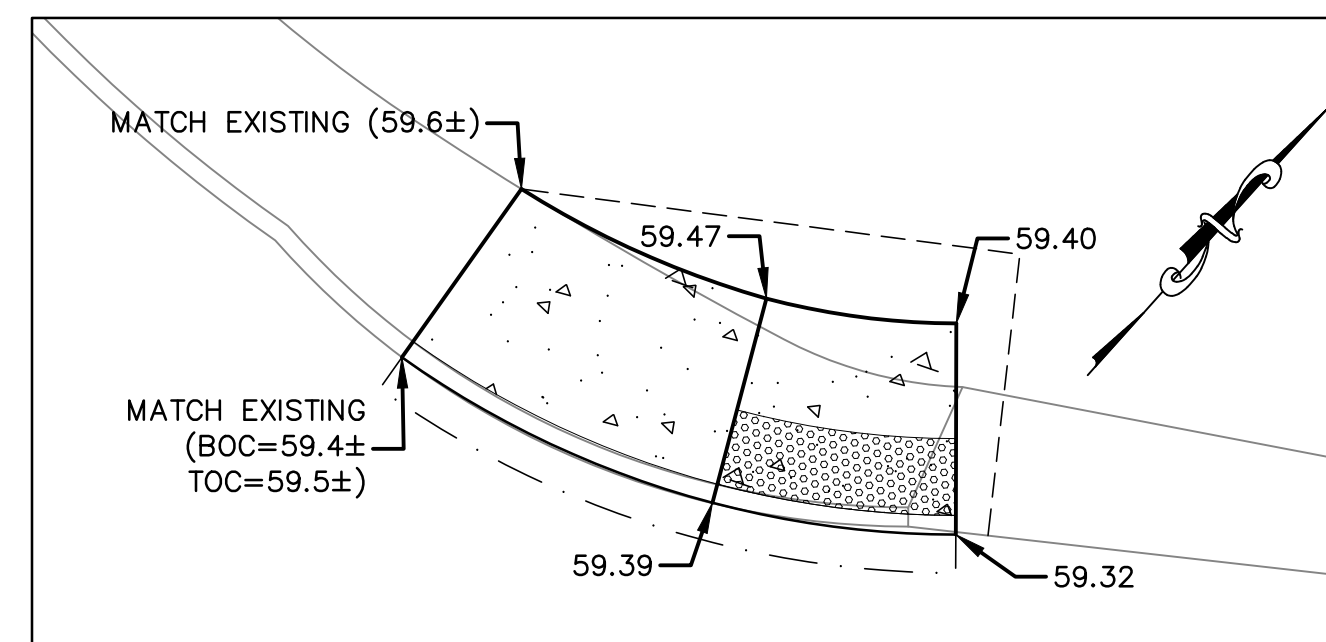

Kingston Road Crossing at Colonial Way

no.	1	Issued for Bidding	date	4/3/2023	by	JUB
revision						

CMA ENGINEERS
 CIVIL/ENVIRONMENTAL/STRUCTURAL
 Portsmouth, NH • Manchester, NH • Portland, ME
 603/431-6196 • 603/627-0708 • 207/541-4223
 c m a e n g i n e e r s . c o m

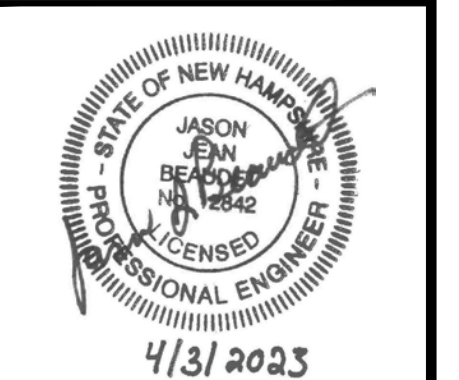

date:	April 2023
designed by:	JUB/STF
project no.:	1030
drawn by:	ATR/STF
file name:	1030- Ramp Details.dwg
approved by:	JUB

scale: 1" = 5'
 0 5' 10'

Town of Exeter, New Hampshire
 Public Works Department
 Kingston Road TAP Project
 Exeter 40436, X-A004(406)
 Ramp Details

drawing no.	D-5
sheet:	10 of 42

ITEM #	IDENT #	SIGN SIZE		TEXT	TEXT DIMENSIONS			SHIELD SIZE (INCH)	ARROW (INCH)	NUMERAL (INCH)	# SIGNS REQ'D	SIGN AREA (SQ. FT)		POSTS PER SIGN					REMARKS			
		WIDTH (INCH)	HEIGHT (INCH)		LETTER HEIGHT (INCH)							NOM. AREA	TOTAL AREA	BREAKAWAY	STEEL I-BEAM	CONCRETE BASE	4" O.D. ALUMINUM U-CHANNEL GALV.					
					UC	LC	CAPS															
615.0301	R1-1	36	36				12C				4	9.00	36.00							1	WHITE/RED	
615.0301	R2-1 (30)	24	30				4E			10E	1	5.00	5.00								1	BLACK/WHITE
615.0301	R2-1 (35)	24	30				4E			10E	1	5.00	5.00								1	BLACK/WHITE
615.0301	R3-8(35)	30	36				4D				1	7.50	7.50								1	BLACK/WHITE
615.0301	R4-5eB1	15	18				3.5C 6C 3.5C				1	1.88	1.88								1	BLACK/WHITE
	R10-25	9	12				1C				2	0.75	1.50									BLACK/WHITE MOUNT ON RRFB (INCIDENTAL TO RRFB)
615.0301	S3-1	36	36								2	9.00	18.00								1	BLACK/FLUORESCENT YELLOW-GREEN
615.0301	W11B-6	36	36				8C				1	9.00	9.00								1	BLACK/YELLOW
615.0301	W11-2	30	30								2	6.25	12.50									BLACK/YELLOW MOUNT ON RRFB
	W11-2	30	30								4	6.25	25.00									BLACK/YELLOW MOUNT ON RRFB (INCIDENTAL TO RRFB)

ITEM #	IDENT #	SIGN SIZE		TEXT	TEXT DIMENSIONS			SHIELD SIZE (INCH)	ARROW (INCH)	NUMERAL (INCH)	# SIGNS REQ'D	SIGN AREA (SQ. FT)		POSTS PER SIGN					REMARKS			
		WIDTH (INCH)	HEIGHT (INCH)		LETTER HEIGHT (INCH)							NOM. AREA	TOTAL AREA	BREAKAWAY	STEEL I-BEAM	CONCRETE BASE	4" O.D. ALUMINUM U-CHANNEL GALV.					
					UC	LC	CAPS															
615.0301	W15-1	36	36								2	9.00	18.00								1	BLACK/YELLOW
615.0601	W16-2aP (250)	24	12								2	2.00	4.00									BLACK/YELLOW MOUNT BELOW W11-2
615.0601	W16-3aP	30	12								1	2.50	2.50									BLACK/YELLOW MOUNT BELOW W11B-6
	W16-7pL	24	12								2	2.00	4.00									BLACK/YELLOW MOUNT BELOW W11-2 (INCIDENTAL TO RRFB)
	W16-7pR	24	12								2	2.00	4.00									BLACK/YELLOW MOUNT BELOW W11-2 (INCIDENTAL TO RRFB)
615.0301	M1-5	24	24							12B	1	4.00	4.00									BLACK/WHITE
615.0601	M3-4	24	12								1	2.00	2.00									BLACK/WHITE MOUNT ABOVE M1-5

NOTES:

- REFER TO THE 2016 STANDARD SPECIFICATIONS FOR ROAD AND BRIDGE CONSTRUCTION PUBLISHED BY THE NHDOT.
- NOTE NEW REFLECTIVITY REQUIREMENTS IN THE 2016 STANDARD SPECIFICATIONS FOR ROAD AND BRIDGE CONSTRUCTION SECTION 718 PUBLISHED BY THE NHDOT.
- REFER TO THE LATEST EDITION OF THE MUTCD FOR EXACT DETAILS OF PERMANENT SIGNING STANDARDS AND TO THE 2010 NHDOT STANDARD PLANS FOR ROAD CONSTRUCTION FOR NHDOT FOR EXACT NHDOT SPECIFIC DETAILS OF PERMANENT SIGNING STANDARDS.
- REFER TO THE LATEST EDITION OF THE MUTCD FOR EXACT DETAILS OF BORDERS, ETC.
- THE MINIMUM SIGN HEIGHT FOR A ROAD SIGN IN A RURAL PROJECT SHALL BE INCREASED FROM 5- FEET TO 6- FEET. ALL OTHER SIGN HEIGHTS SHALL BE IN ACCORDANCE WITH THE LATEST EDITION OF THE MUTCD.
- ALL WARNING SIGNS SHALL HAVE TYPE IV BACKGROUND SHEETING UNLESS OTHERWISE SPECIFIED.
- ALL EXISTING SIGNS THAT ARE REMOVED ARE TO BE STORED BY THE CONTRACTOR AND RESET AS DIRECTED. ANY EXISTING SIGNS TO BE RESET THAT ARE DAMAGED BY THE CONTRACTOR'S OPERATIONS ARE TO BE REPLACED BY THE CONTRACTOR AT NO ADDITIONAL COST TO THE TOWN.
- THE ALUMINUM OR U-CHANNEL POST SHALL BE FLUSH WITH THE TOP OF THE SIGN ON ALL SINGLE POST ASSEMBLIES.
- SIGNS SHALL NOT BE MOUNTED ON LIGHT POLES.
- DIGITALLY PRINTED SIGNS ARE NOT PERMITTED.
- ALL EXISTING SIGNS WITHIN THE PROJECT ARE OWNED BY NHDOT. ANY SIGN/POST THAT IS REMOVED AND NOT RESET SHALL BE SALVAGED TO NHDOT.

designed by: JUB/STF	drawn by: ATP/STF	approved by: JUB
date: April 2023	project no: 1030	file name: 1030-Sign Text.dwg
scale:		
<p>Town of Exeter, New Hampshire Public Works Department Kingston Road TAP Project Exeter 40436, X-A004(406) Sign Text Layout</p>		
drawing no. STL-1		
sheet: 11 of 42	revision	no.
4/3/2023	date	by
Issued for Bidding		
<p>CMA ENGINEERS CIVIL/ENVIRONMENTAL/STRUCTURAL Portsmouth, NH • 603/431-6196 Manchester, NH • 603/627-0708 Portland, ME • 207/541-4223 c m a e n g i n e e r s . c o m</p>		

CONTROL POINTS:				
POINT #	NORTHING	EASTING	ELEVATION	DESCRIPTION
1	171466.3257	1166614.9570	69.84	REBAR WITH CAP
2	171611.3432	1166769.3327	76.16	MAGNAIL
3	171674.4239	1167259.8978	76.44	MAGNAIL
4	172096.3690	1167668.3832	51.29	REBAR WITH CAP
5	172407.2618	1168166.0131	54.36	REBAR WITH CAP
6	172461.4459	1168410.4490	52.33	REBAR WITH CAP
7	172738.1633	1168923.9313	59.33	MAGNAIL FOUND
8	173054.2408	1169078.1963	58.77	MAGNAIL
9	173308.8284	1169251.0689	56.90	MAGNAIL
10	173575.7635	1169359.1117	59.74	MAGNAIL
11	173736.0357	1169659.3183	51.93	REBAR WITH CAP
12	174154.6397	1169970.8506	50.60	MAGNAIL
13	174380.2107	1170570.5366	40.26	REBAR WITH CAP
14	174466.8311	1170722.1363	40.40	REBAR WITH CAP
15	174849.3767	1170929.1035	34.66	MAGNAIL
16	174913.3015	1171000.6124	35.66	MAGNAIL
17	174816.9477	1170947.6621	35.15	DRILL HOLE
18	173422.4646	1169217.7130	52.77	MAGNAIL TEMP
19	173355.5753	1169205.1245	53.67	HUB AND TACK

BENCHMARKS:				
ID	NORTHING	EASTING	ELEVATION	DESCRIPTION
TBM A	171621	1166689	76.60	MAGNAIL IN UPL 325
TBM C	172074	1167640	53.10	MAGNAIL IN UPL 36
TBM B	171766	1167247	77.25	NAIL IN UPL
TBM D	173319	1169264	56.57	MAGNAIL IN UPL 349
TBM E	174166	1169961	52.22	MAGNAIL IN UPL 219
TBM F	174973	1171036	37.21	MAGNAIL IN UPL

REFERENCE PLANS:

FROM THE ROCKINGHAM COUNTY REGISTRY OF DEEDS:

- PLAN 170
- PLAN C-2801
- PLAN C-13118
- PLAN C-16387
- PLAN C-21274
- PLAN C-31126
- PLAN C-31412
- PLAN D-1718A
- PLAN D-6336
- PLAN D-7784
- PLAN D-8534
- PLAN D-9033
- PLAN D-9414
- PLAN D-9735
- PLAN D-14703
- PLAN D-14911
- PLAN D-15000
- PLAN D-15176
- PLAN D-21184
- PLAN D-21633
- PLAN D-23001
- PLAN D-30077
- PLAN D-35705
- PLAN D-36761
- PLAN D-38807

FROM THE TOWN OF EXETER:

- "PHASE II SITE PLAN FOR BRICKYARD BUSINESS CONDOMINIUM IN EXETER, NH" DATED NOVEMBER 1986 AND PREPARED BY PARKER SURVEY ASSOCIATES
- "SUBDIVISION OF LAND "GREYBIRD FARM ESTATES" IN EXETER, NH FOR GREYBIRD DEVELOPMENT CORP." DATED MARCH 1991 AND REVISED APRIL 15, 1991 PREPARED BY WILLIAM G. COLLINS ASSOCIATES
- "LOT LINE ADJUSTMENT PLAN OF LAND, PICKPOCKET ROAD, KINGSTON ROAD (N.H. ROUTE 111), AND JOLLY RAND ROAD, EXETER NEW HAMPSHIRE, COUNTY OF ROCKINGHAM" DATED FEBRUARY 5, 2003 PREPARED BY CIVILWORKS, ENGINEERS & SURVEYORS

SURVEY NOTES:

1. THE BASEPLAN WAS COMPILED FROM TRADITIONAL FIELD SURVEY COLLECTED BY GREENMAN-PEDERSEN, INC. IN AUGUST AND SEPTEMBER OF 2016.
2. THE HORIZONTAL DATUM SHOWN HEREON IS BASED UPON THE NEW HAMPSHIRE STATE PLANE COORDINATE SYSTEM REFERENCED TO THE NORTH AMERICAN DATUM OF 1983 (NAD83) AND WAS ESTABLISHED VIA GPS OBSERVATION.
3. THE VERTICAL DATUM SHOWN HEREON WAS ESTABLISHED BY GREENMAN-PEDERSEN, INC. AND REFERENCES THE NORTH AMERICAN VERTICAL DATUM OF 1988 (NAV88) AND WAS ESTABLISHED VIA GPS OBSERVATION.
4. THE UNITS SHOWN HEREIN ARE US SURVEY FEET.
5. CONTOUR INTERVAL: 1 FOOT
6. RIGHT OF WAY AND BOUNDARY LINES SHOWN WERE COMPILED FROM THE REFERENCE PLANS NOTED HEREON, DEEDS OF RECORD, ASSESSORS INFORMATION AND PHYSICAL EVIDENCE FOUND DURING FIELD SURVEY. THIS IS NOT TO BE CONSIDERED A BOUNDARY SURVEY.
7. SUBSURFACE UTILITY INFORMATION SHOWN HEREON IS APPROXIMATE ONLY AND WAS COMPILED FROM SURFACE EVIDENCE AND SUPPLEMENTED WITH RECORD UTILITY INFORMATION WHERE AVAILABLE AND IS IN COMPLIANCE WITH THE FEDERAL HIGHWAY ADMINISTRATION UTILITY DATA QUALITY LEVEL C. GREENMAN-PEDERSEN, INC. ASSUMES NO RESPONSIBILITY FOR DAMAGES INCURRED AS A RESULT OF UTILITIES OMITTED OR INACCURATELY SHOWN. THE SURVEYOR HAS NOT PHYSICALLY LOCATED THE UNDERGROUND UTILITIES. COORDINATION WITH THE APPROPRIATE UTILITIES BEFORE AND DURING DESIGN OF FUTURE CONNECTIONS IS REQUIRED.
8. WETLAND RESOURCE AREAS WERE DELINEATED BY ROBERT PROKOP (WETLAND SCIENTIST #063) OF WETLAND CONSULTANT SERVICES IN JULY 2016 AND FLAGS WERE FIELD LOCATED BY GREENMAN-PEDERSEN, INC. IN AUGUST 2016.
9. CONTACT "DIG SAFE" AT 1 (888) 344-7233 PRIOR TO CONSTRUCTION.

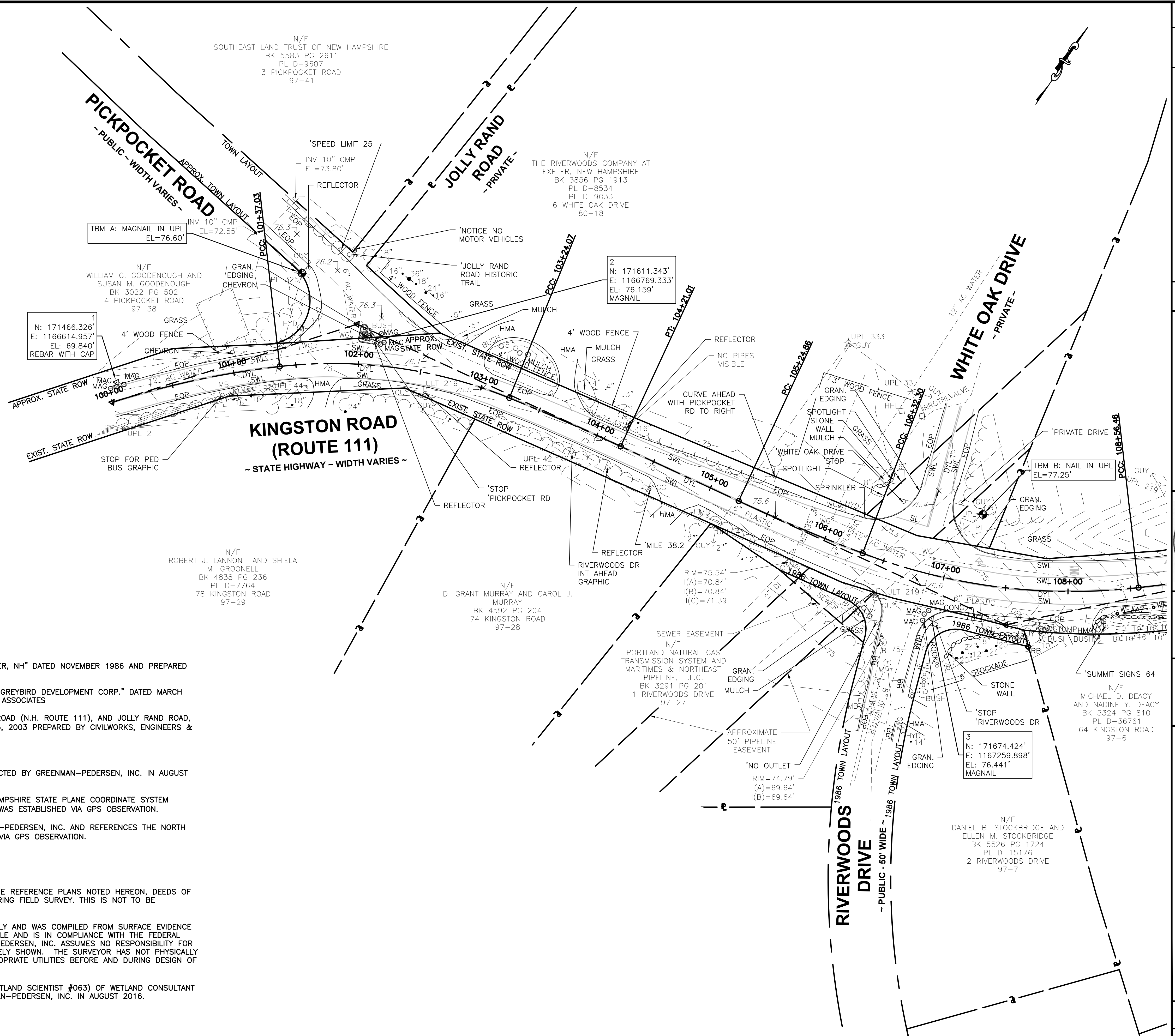

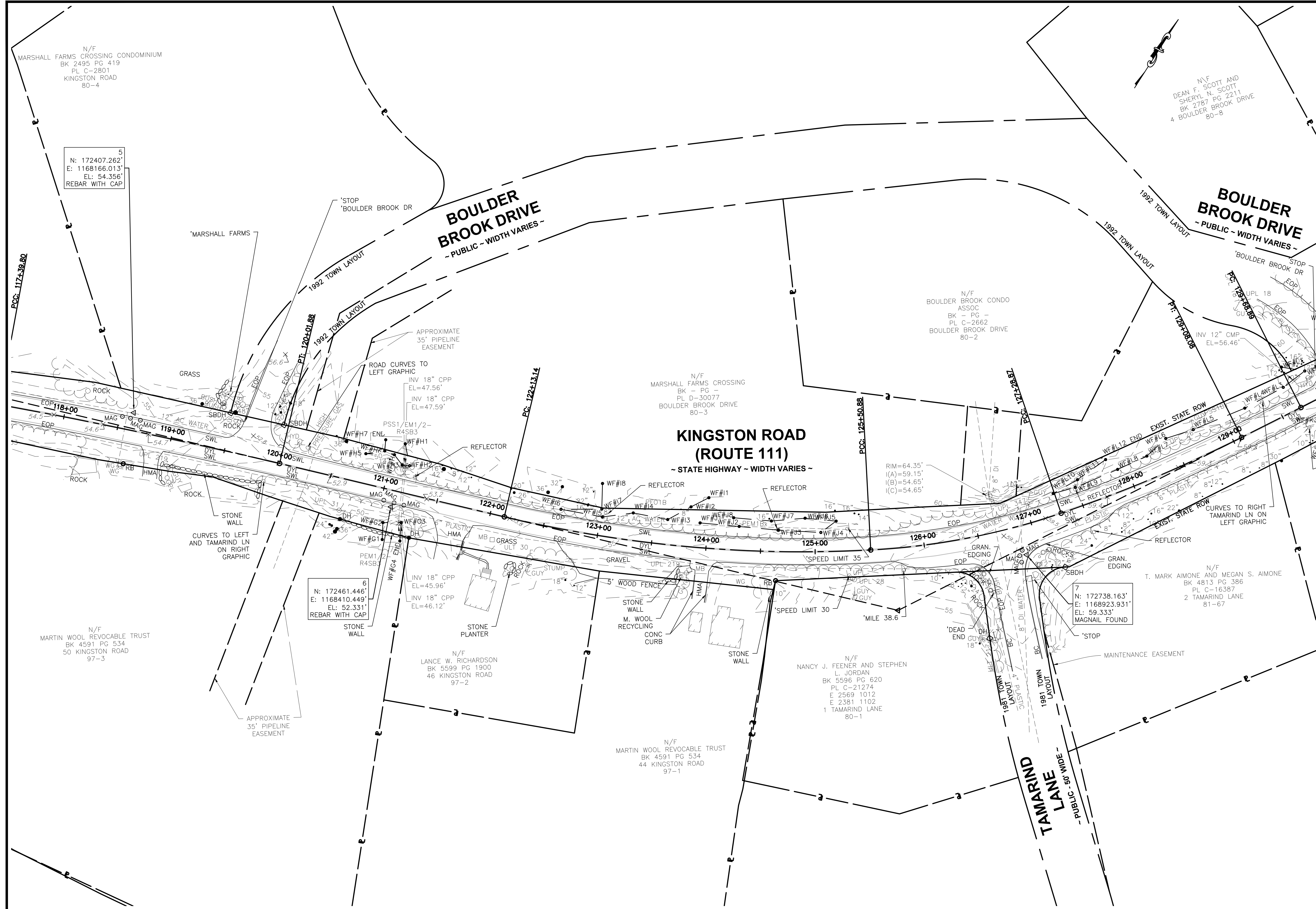

		CIVIL/ENVIRONMENTAL/STRUCTURAL Portsmouth, NH • Manchester, NH • Portland, ME 603/431-6196 • 603/627-0708 • 207/641-4223 c m a e n g i n e e r s . c o m	
		designed by: JUB/STF drawn by: ATR/STF approved by: JUB date: April 2023 project no: 1030 file name: 1030-ECP.dwg scale: 1" = 40' 0 40' 80'	
Town of Exeter, New Hampshire Public Works Department Kingston Road TAP Project Exeter 40436, X-A004(406)		Existing Conditions Plan drawing no. ECP-1 sheet: 12 of 42	



5
 N: 172407.262'
 E: 1168166.013'
 EL: 54.356'
 REBAR WITH CAP

6
 N: 172461.446'
 E: 1168410.449'
 EL: 52.331'
 REBAR WITH CAP

7
 N: 172738.163'
 E: 1168923.931'
 EL: 59.333'
 MAGNAIL FOUND

 CIVIL/ENVIRONMENTAL/STRUCTURAL Portsmouth, NH • Manchester, NH • Portland, ME 603/431-6196 • 603/627-0708 • 207/641-4223 c m a e n g i n e e r s . c o m	
designed by: JUB/STF	date: April 2023
drawn by: ATR/STF	project no: 1030
approved by: JUB	file name: 1030-ECP.dwg
scale: 1" = 40' 	
Town of Exeter, New Hampshire Public Works Department Kingston Road TAP Project Exeter 40436, X-A004(406) Existing Conditions Plan	
drawing no. ECP-3	
sheet: 14 of 42	no. 1 date 4/3/2023 by JUB

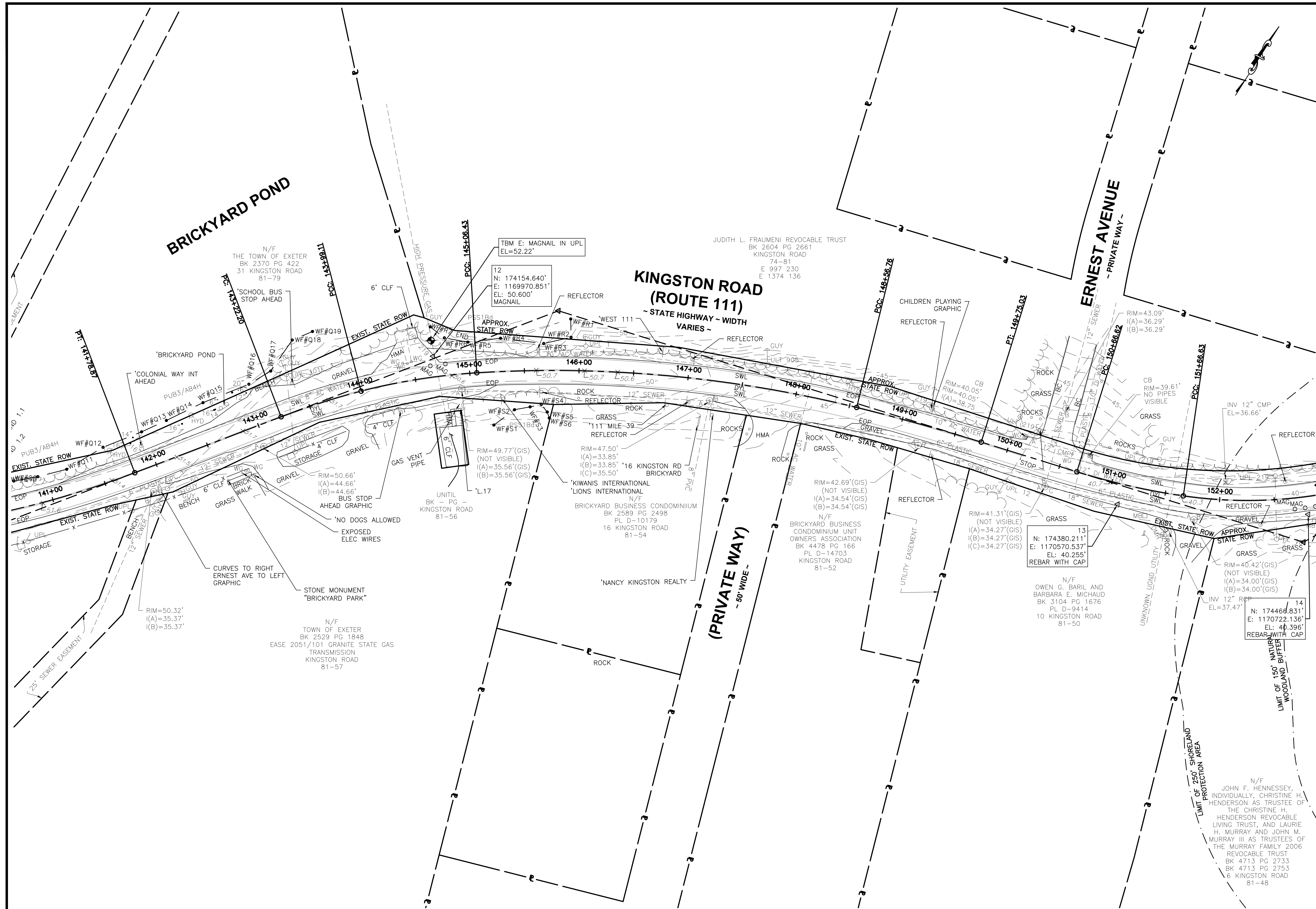

<p>CMA ENGINEERS CIVIL/ENVIRONMENTAL/STRUCTURAL</p> <p>Portsmouth, NH • Manchester, NH • Portland, ME 603/431-6196 • 603/627-0708 • 207/541-4223</p> <p>cmaengineers.com</p>	
<p>ROBERT PROKOP No. 083 REGISTERED PROFESSIONAL ENGINEER STATE OF NEW HAMPSHIRE</p>	
designed by: JUB/STF	date: April 2023
drawn by: ATRS/STF	project no: 1030
approved by: JUB	file name: 1030-ECP.dwg
scale: 1" = 40' 	
Town of Exeter, New Hampshire Public Works Department Kingston Road TAP Project Exeter 40436, X-A004(406) Existing Conditions Plan	
drawing no. ECP-5	
sheet: 16 of 42	no. 1
revision	date 4/3/2023
by JUB	date 4/3/2023

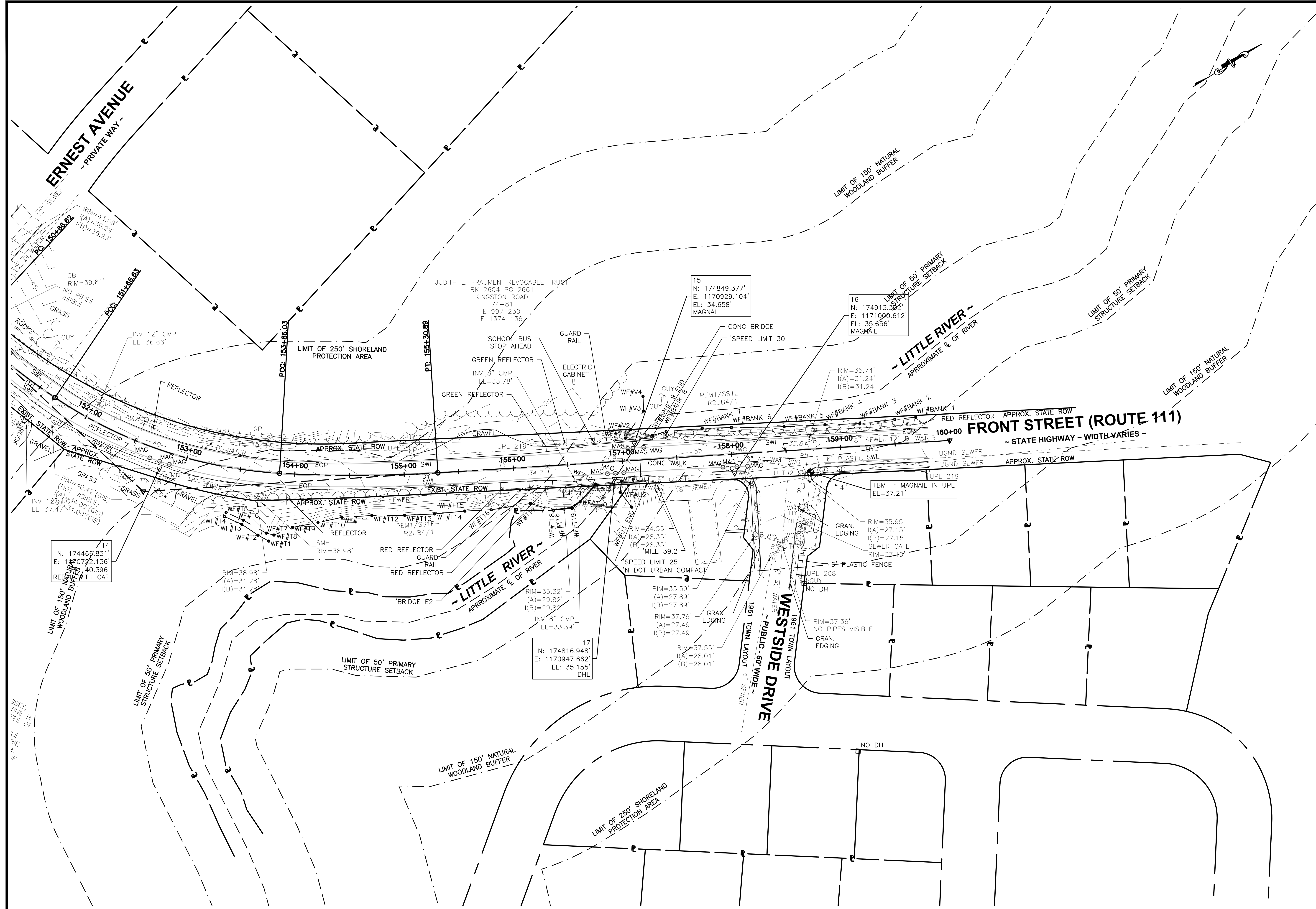

<p>CIVIL/ENVIRONMENTAL/STRUCTURAL</p> <p>Portsmouth, NH • Manchester, NH • Portland, ME 603/431-6196 • 603/627-0708 • 207/541-4223</p> <p>c m a e n g i n e e r s . c o m</p>	
	<p>designed by: JUB/STF</p> <p>drawn by: ATR/STF</p> <p>approved by: JUB</p>
<p>date: April 2023</p> <p>project no: 1030</p> <p>file name: 1030-ECP.dwg</p>	<p>scale: 1" = 40'</p> <p>Scale: 1" = 40'</p>
<p>Town of Exeter, New Hampshire Public Works Department Kingston Road TAP Project Exeter 40436, X-A004(406) Existing Conditions Plan</p>	
<p>drawing no. ECP-6</p>	
<p>sheet: 17 of 42</p>	<p>no. 1</p> <p>revision</p> <p>date 4/3/2023</p> <p>JUB by</p>

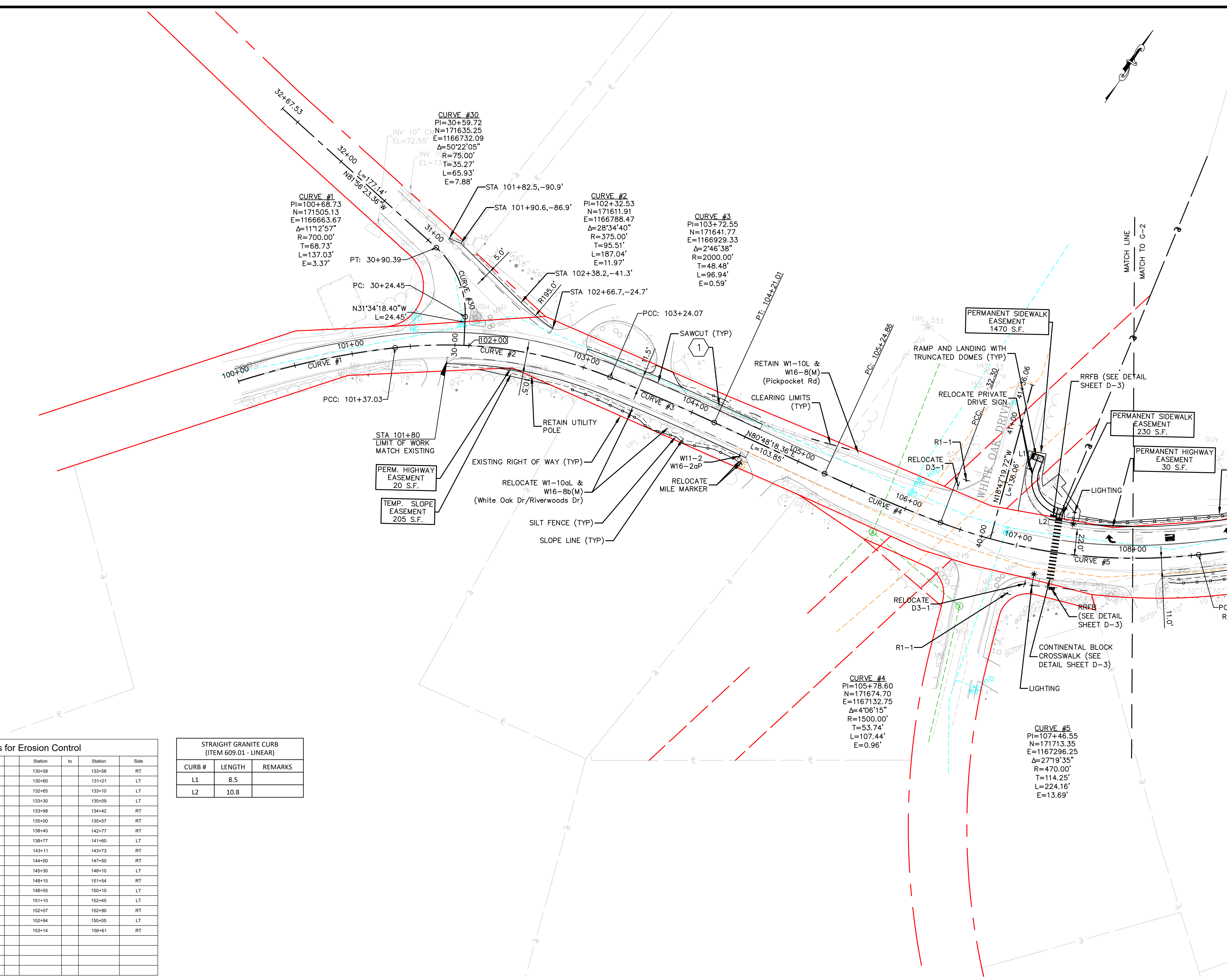

Station Limits for Erosion Control

Station	to	Station	Side	Station	to	Station	Side
102+95		104+58	RT	130+58		133+58	RT
104+05		104+25	LT	130+60		131+21	LT
104+45		104+55	LT	132+65		133+10	LT
107+40		109+95	LT	133+30		135+09	LT
108+30		110+85	RT	133+98		134+42	RT
110+70		111+16	LT	135+00		135+57	RT
111+45		111+75	RT	138+45		142+77	RT
111+80		113+15	LT	138+77		141+60	LT
112+35		114+40	RT	143+11		143+73	RT
113+75		118+50	LT	144+00		147+50	RT
114+59		115+20	RT	145+30		148+10	LT
116+64		118+60	RT	148+15		151+54	RT
119+00		121+40	RT	148+55		150+10	LT
119+05		119+51	LT	151+10		152+45	LT
120+04		120+80	RT	152+07		152+90	RT
121+25		126+80	LT	152+94		155+05	LT
123+00		123+81	RT	153+14		156+61	RT
125+37		125+80	RT				
126+89		129+70	RT				
127+10		127+68	LT				
127+79		129+93	LT				

STRAIGHT GRANITE CURB (ITEM 609.01 - LINEAR)

CURB #	LENGTH	REMARKS
L1	8.5	
L2	10.8	

designed by: JUB/STF

drawn by: ATR/STF

approved by: JUB

date: April 2023

project no: 1030

file name: 1030-GenPlans.dwg

scale: 1" = 40'

town of Exeter, New Hampshire
Public Works Department
Kingston Road TAP Project
Exeter 40436, X-A004(406)

General Plan
STA 100+00 to STA 108+00

drawing no:
G-1

sheet: 18 of 42

revision: 1

no. 1

date: 4/3/2023

by: JUB

CMA ENGINEERS
Civil/Environmental/Structural
Portsmouth, NH • Manchester, NH • Portland, ME
603/431-6196 • 603/627-0708 • 207/541-4223
c m a e n g i n e e r s . c o m

M:\CADD\PROJECTS\1030 Exeter TAP\Production\1030-GenPlans.dwg Date Plotted: Mar 31, 2023 9:56am Plotted By: WGORDON

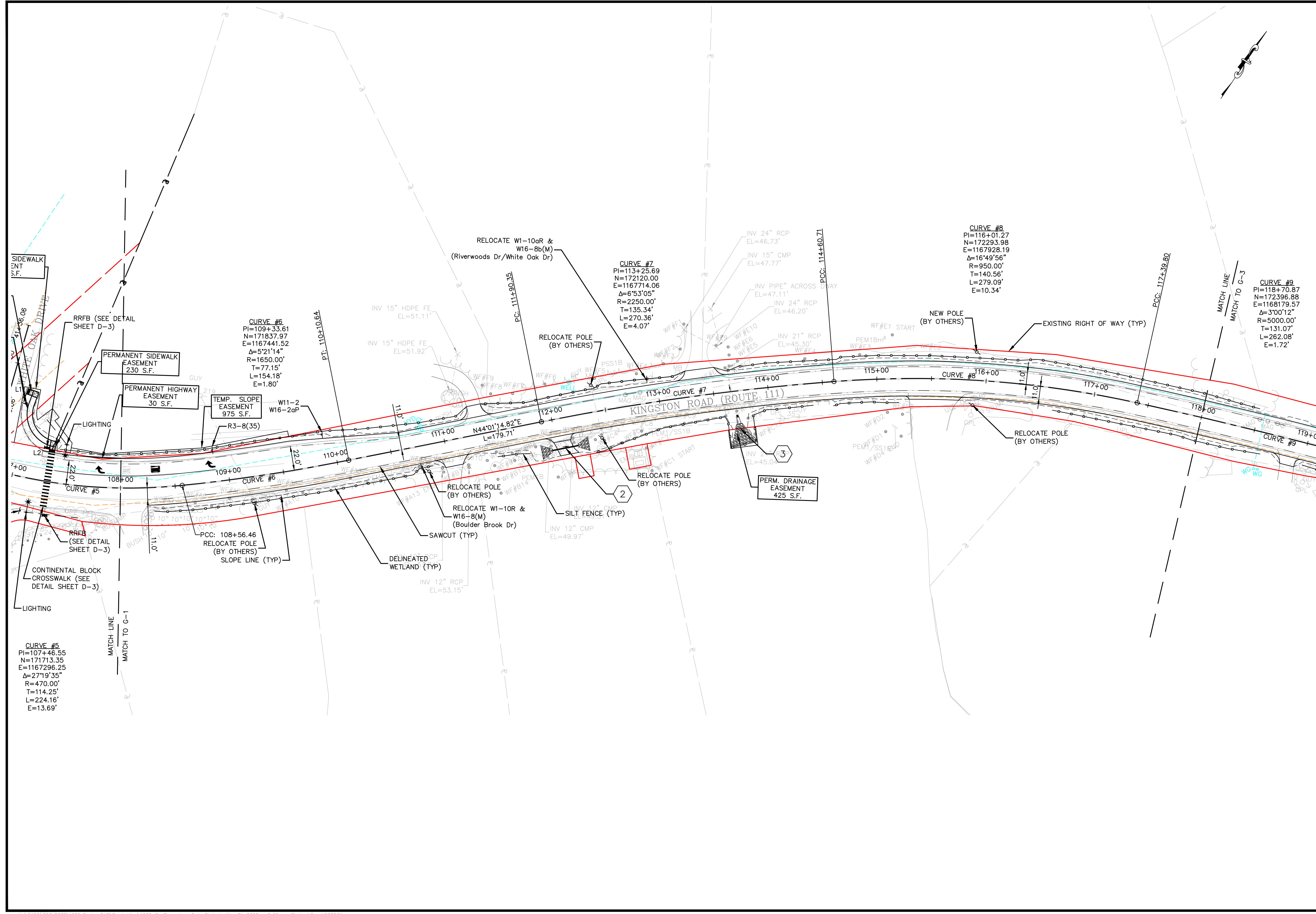

CURVE #5
 PI=107+46.55
 N=171713.35
 E=1167296.25
 $\Delta=27^{\circ}19'35''$
 R=470.00'
 T=114.25'
 L=224.16'
 E=13.69'

CURVE #6
 PI=109+33.61
 N=171837.97
 E=1167441.52
 $\Delta=5^{\circ}21'14''$
 R=1650.00'
 T=77.15'
 L=154.18'
 E=1.80'

CURVE #7
 PI=113+25.69
 N=172120.00
 E=1167714.06
 $\Delta=6^{\circ}53'05''$
 R=2250.00'
 T=135.34'
 L=270.36'
 E=4.07'

CURVE #8
 PI=116+01.27
 N=172293.98
 E=1167928.19
 $\Delta=16^{\circ}49'56''$
 R=950.00'
 T=140.56'
 L=279.09'
 E=10.34'

CURVE #9
 PI=118+70.87
 N=172396.88
 E=1168179.57
 $\Delta=3^{\circ}00'12''$
 R=5000.00'
 T=131.07'
 L=262.08'
 E=1.72'

 CIVIL/ENVIRONMENTAL/STRUCTURAL Portsmouth, NH • Manchester, NH • Portland, ME 603/431-6196 • 603/627-0708 • 207/541-4223 c m a e n g i n e e r s . c o m		
designed by: JUB/STF	drawn by: ATR/STF	approved by: JUB
date: April 2023	project no: 1030	file name: 1030-GenPlans.dwg
scale: 0 40' 80' Scale: 1" = 40'		
Town of Exeter, New Hampshire Public Works Department Kingston Road TAP Project Exeter 40436, X-A004(406) General Plan STA 108+00 to STA 118+00		
drawing no. G-2		
sheet: 19	of 42	no. 1 date 4/3/2023 by JUB

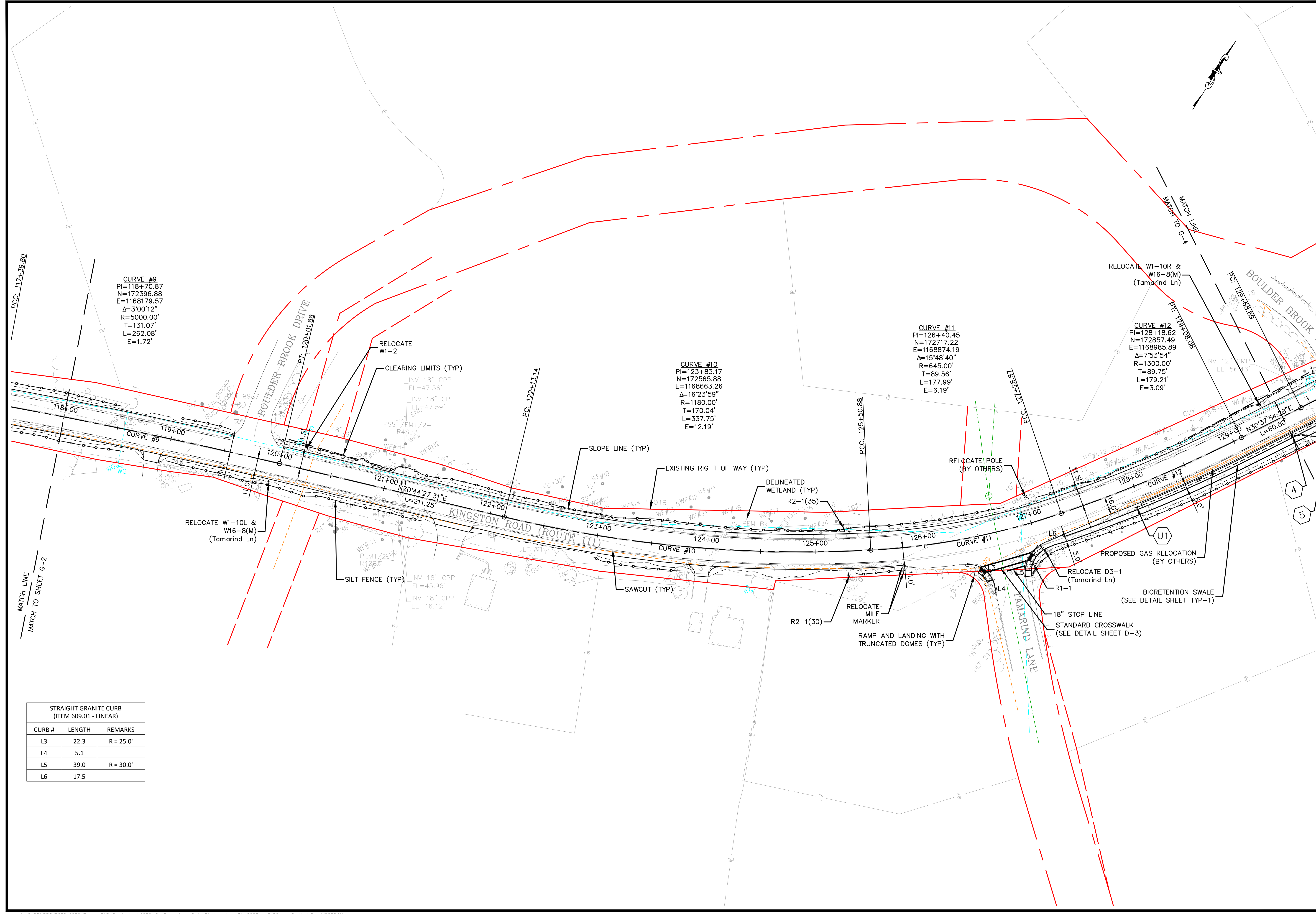

CURVE #9
 PI=118+70.87
 N=172396.88
 E=1168179.57
 Δ=3'00"12"
 R=5000.00'
 T=131.07'
 L=262.08'
 E=1.72'

CURVE #10
 PI=123+83.17
 N=172565.88
 E=1168663.26
 Δ=16'23"59"
 R=1180.00'
 T=170.04'
 L=337.75'
 E=12.19'

CURVE #11
 PI=126+40.45
 N=172717.22
 E=1168874.19
 Δ=15'48"40"
 R=645.00'
 T=89.56'
 L=177.99'
 E=6.19'

CURVE #12
 PI=128+18.62
 N=172857.49
 E=1168985.89
 Δ=7'53"54"
 R=1300.00'
 T=89.75'
 L=179.21'
 E=3.09'

STRAIGHT GRANITE CURB (ITEM 609.01 - LINEAR)		
CURB #	LENGTH	REMARKS
L3	22.3	R = 25.0'
L4	5.1	
L5	39.0	R = 30.0'
L6	17.5	

<p>CIVIL/ENVIRONMENTAL/STRUCTURAL</p> <p>Portsmouth, NH • Manchester, NH • Portland, ME 603/431-6196 • 603/627-0708 • 207/641-4223</p> <p style="text-align: right;">c m a e n g i n e e r s . c o m</p>							
<p style="text-align: center;">4/3/2023</p>							
date:	April 2023	project no.:	1030	file name:	1030-GenPlans.dwg	scale:	1" = 40'
designed by:	JUB/STF	drawn by:	ATP/STF	approved by:	JUB		
Town of Exeter, New Hampshire Public Works Department Kingston Road TAP Project Exeter 40436, X-A004(406)				General Plan STA 118+00 to STA 129+50			
drawing no. G-3							
sheet: 20 of 42							

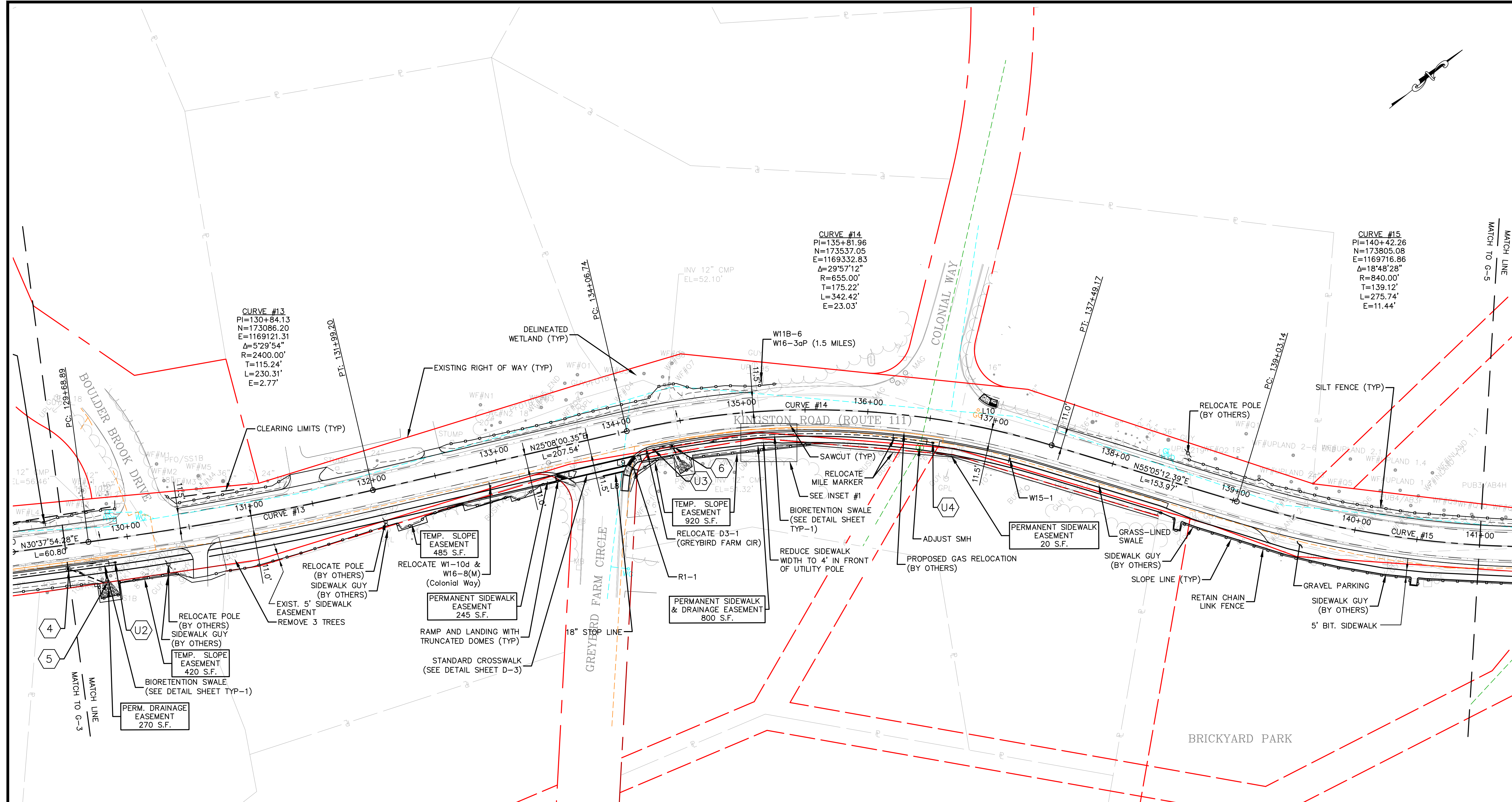

STRAIGHT GRANITE CURB (ITEM 609.01 - LINEAR)		
CURB #	LENGTH	REMARKS
L7	16.1	R = 40.0'
L8	8.1	
L9	21.9	R = 30.0'
L10	15.4	R = 25.0'

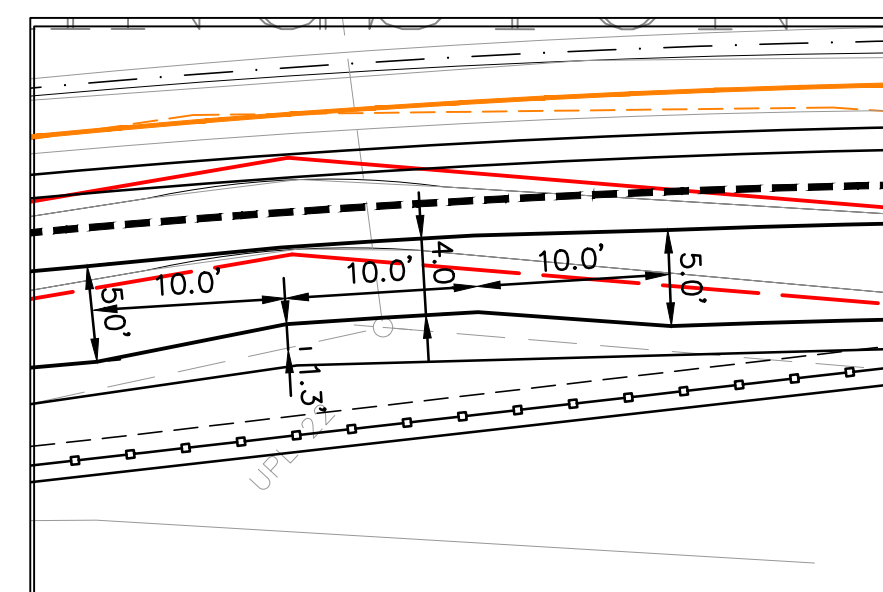

4/3/2023
 date

1
 no.

Issued for Bidding
 revision

CMA ENGINEERS
 CIVIL/ENVIRONMENTAL/STRUCTURAL

Portsmouth, NH • Manchester, NH • Portland, ME
 603/431-6196 • 603/627-0708 • 207/541-4223

c m a e n g i n e e r s . c o m

4/3/2023

date: April 2023	designed by: JUB/STF	project no.: 1030	drawn by: ATF/STF
		file name: 1030-GenPlans.dwg	approved by: JUB

scale:
 0 40' 80'
 1" = 40'

Town of Exeter, New Hampshire
 Public Works Department
 Kingston Road TAP Project
 Exeter 40436, X-A004(406)
 General Plan
 STA 129+50 to STA 141+00

drawing no.
G-4

sheet: 21 of 42

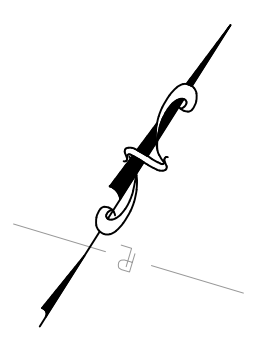
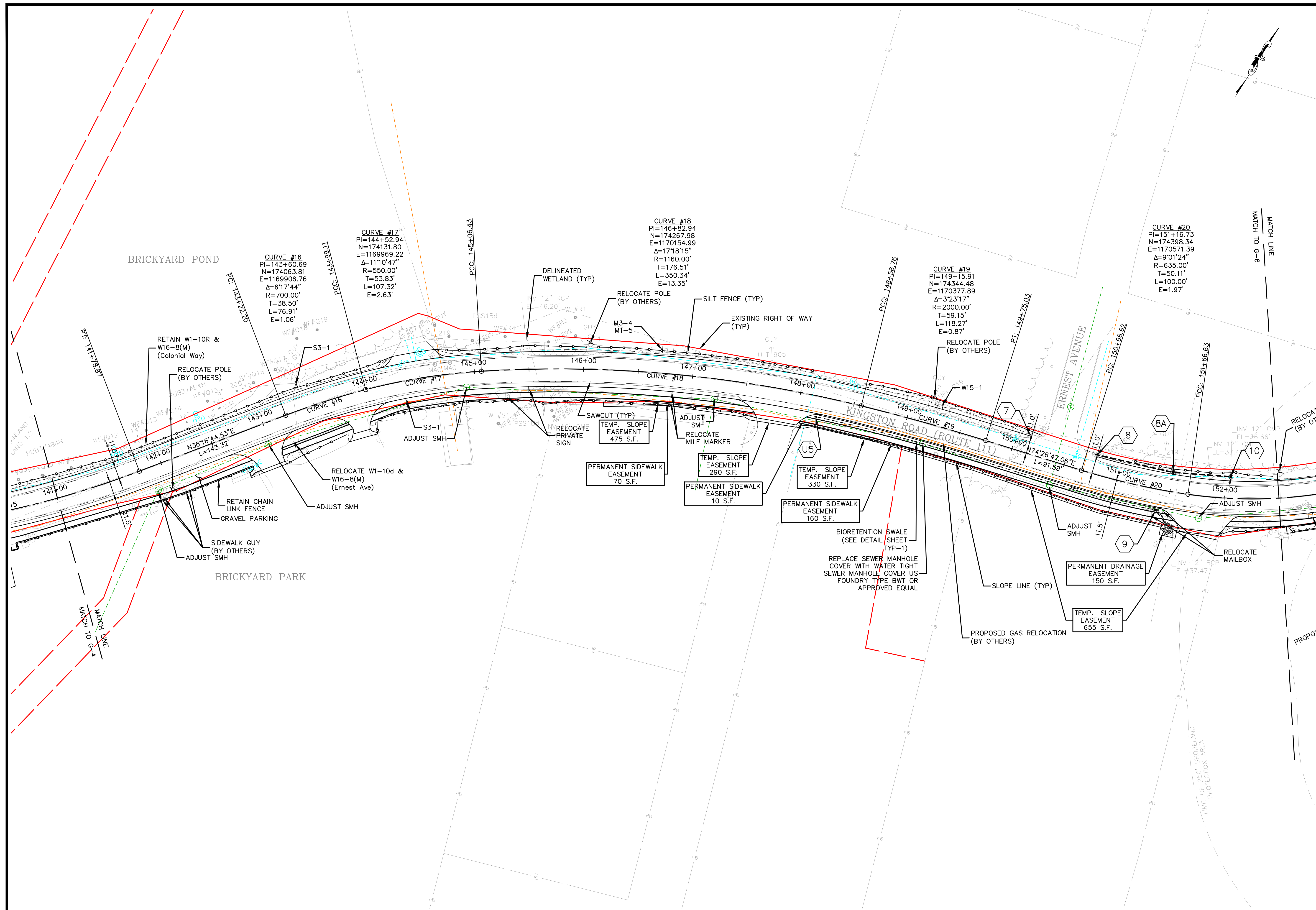

no.	1	Issued for Bidding	4/3/2023	JUB	by
revision					

CMA ENGINEERS
 CIVIL/ENVIRONMENTAL/STRUCTURAL
 Portsmouth, NH • Manchester, NH • Portland, ME
 603/431-6196 • 603/627-0708 • 207/641-4223
 c m a e n g i n e e r s . c o m

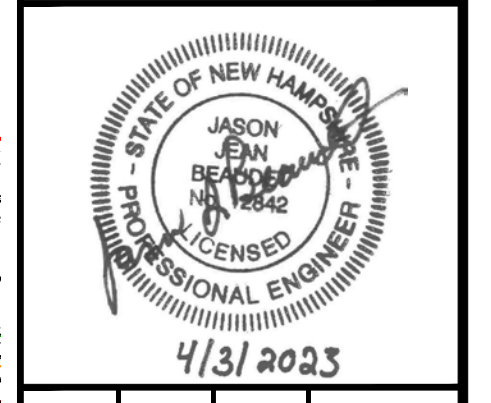

date:	April 2023	designed by:	JUB/STF
project no:	1030	drawn by:	ATR/STF
file name:	1030-GenPlans.dwg	approved by:	JUB

Town of Exeter, New Hampshire
 Public Works Department
 Kingston Road TAP Project
 Exeter 40436, X-A004(406)
 General Plan
 STA 141+00 to STA 152+50

drawing no.
G-5
 sheet: 22 of 42

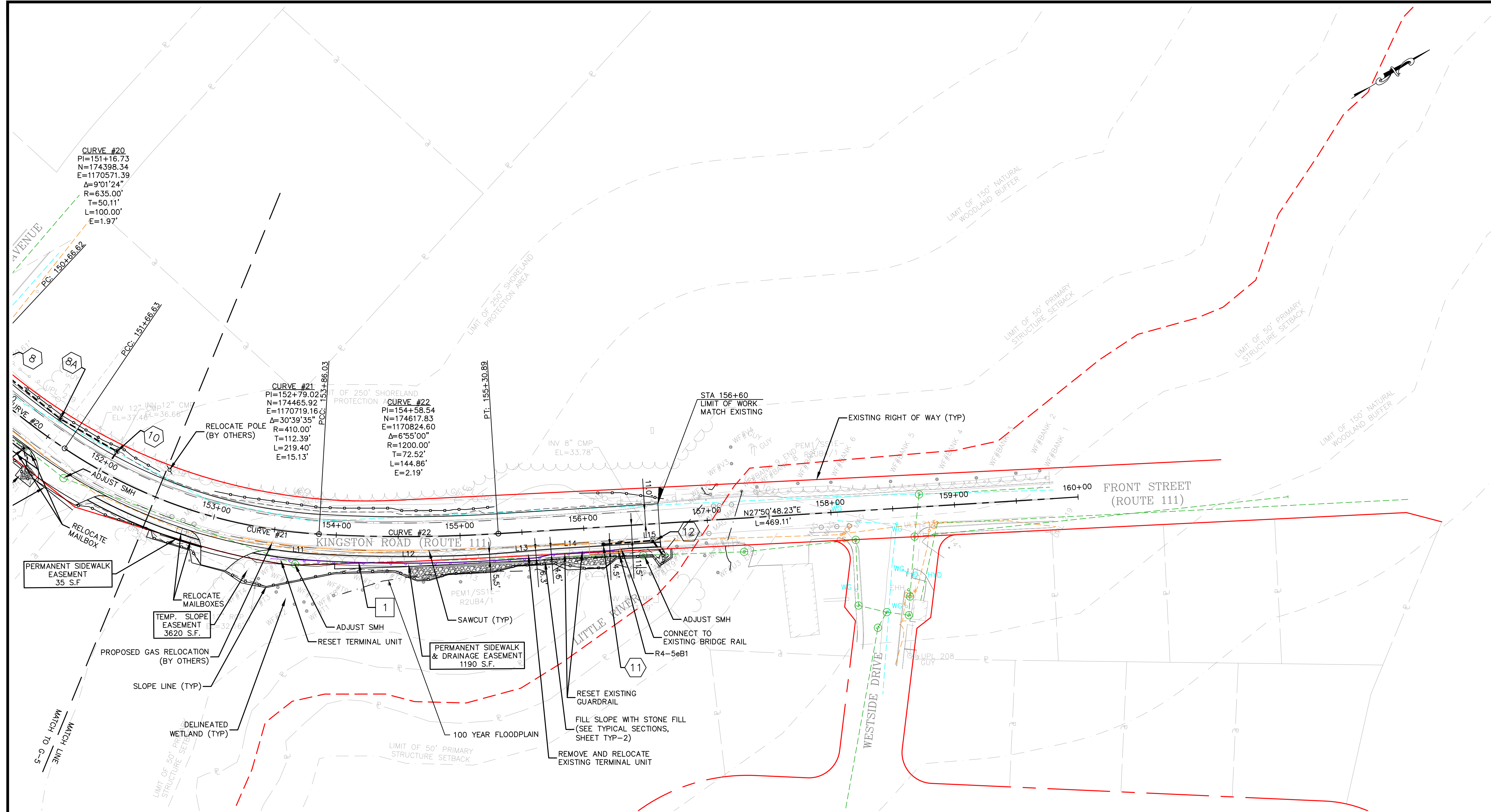

CURVE #20
 PI=151+16.73
 N=174398.34
 E=1170571.39
 $\Delta=9^{\circ}01'24''$
 R=635.00'
 T=50.11'
 L=100.00'
 E=1.97'

CURVE #21
 PI=152+79.02
 N=174465.92
 E=1170719.16
 $\Delta=30^{\circ}39'35''$
 R=410.00'
 T=112.39'
 L=219.40'
 E=15.13'

CURVE #22
 PI=154+58.54
 N=174617.83
 E=1170824.60
 $\Delta=6^{\circ}55'00''$
 R=1200.00'
 T=72.52'
 L=144.86'
 E=2.19'

STRAIGHT GRANITE CURB
 (ITEM 609.01 - LINEAR)

CURB #	LENGTH	REMARKS
L11	30.7	R = 426.0'
L12	138.6	R = 1,216.0'
L13	50.0	
L14	78.3	
L15	10.0	

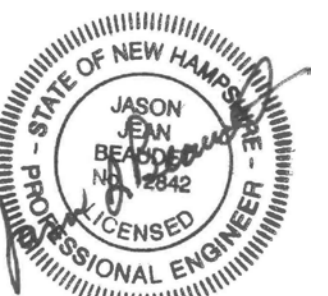
 CIVIL/ENVIRONMENTAL/STRUCTURAL Portsmouth, NH • Manchester, NH • Portland, ME 603/431-6196 • 603/627-0708 • 207/541-4223 c m a e n g i n e e r s . c o m	
 4/3/2023	
designed by: JUB/STF	drawn by: ATR/STF
date: April 2023	project no: 1030
approved by: JUB	file name: 1030-GenPlans.dwg
scale: 0 40' 80' Scale: 1" = 40'	
Town of Exeter, New Hampshire Public Works Department Kingston Road TAP Project Exeter 40436, X-A004(406) General Plan STA 152+50 to STA 160+00	
drawing no. G-6	
sheet: 23	of 42
no. 1	revision date 4/3/2023
by JUB	date 4/3/2023

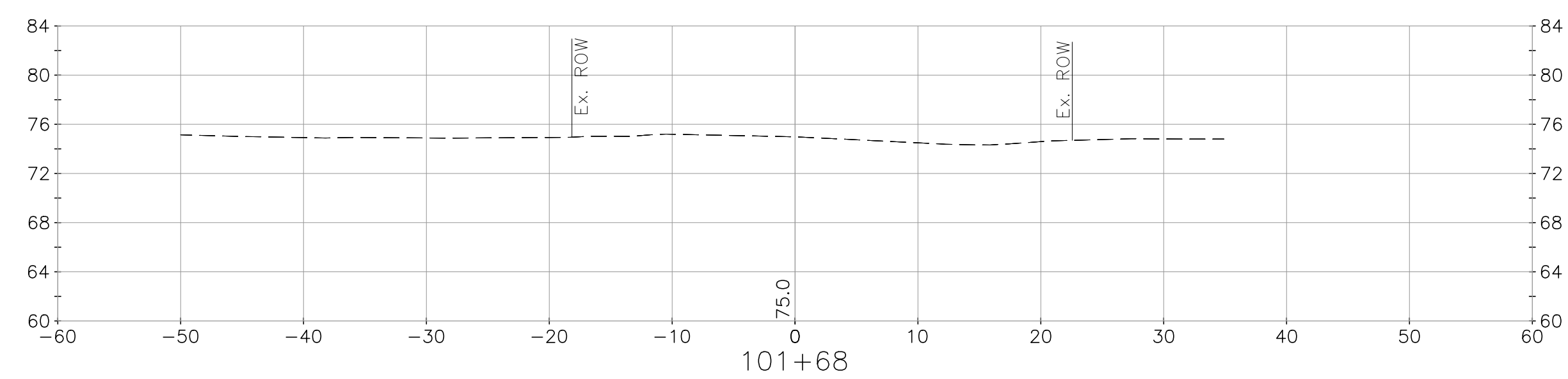
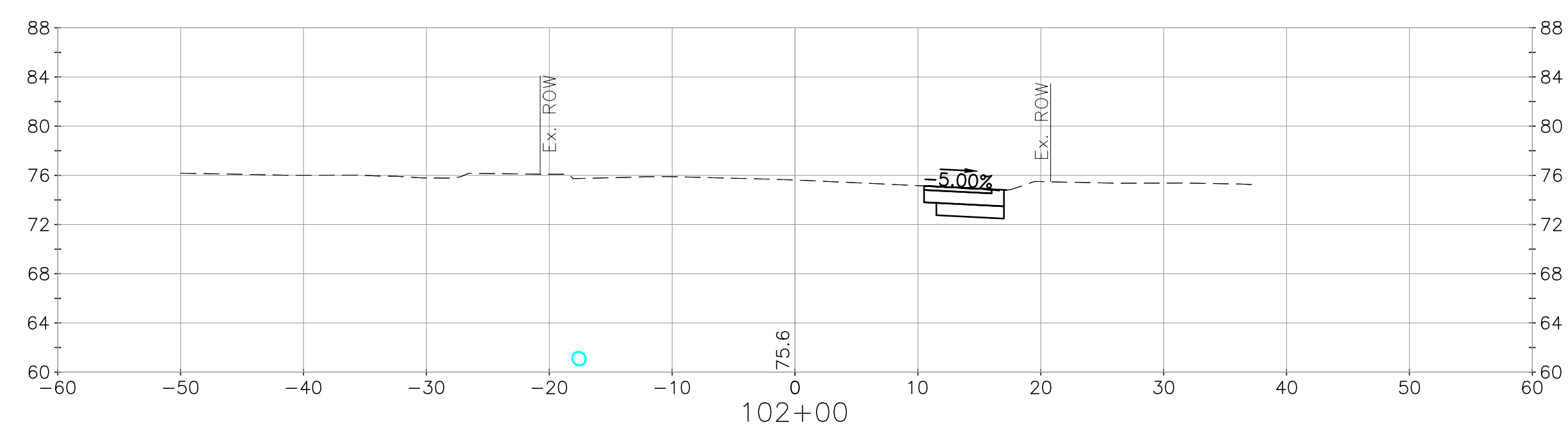
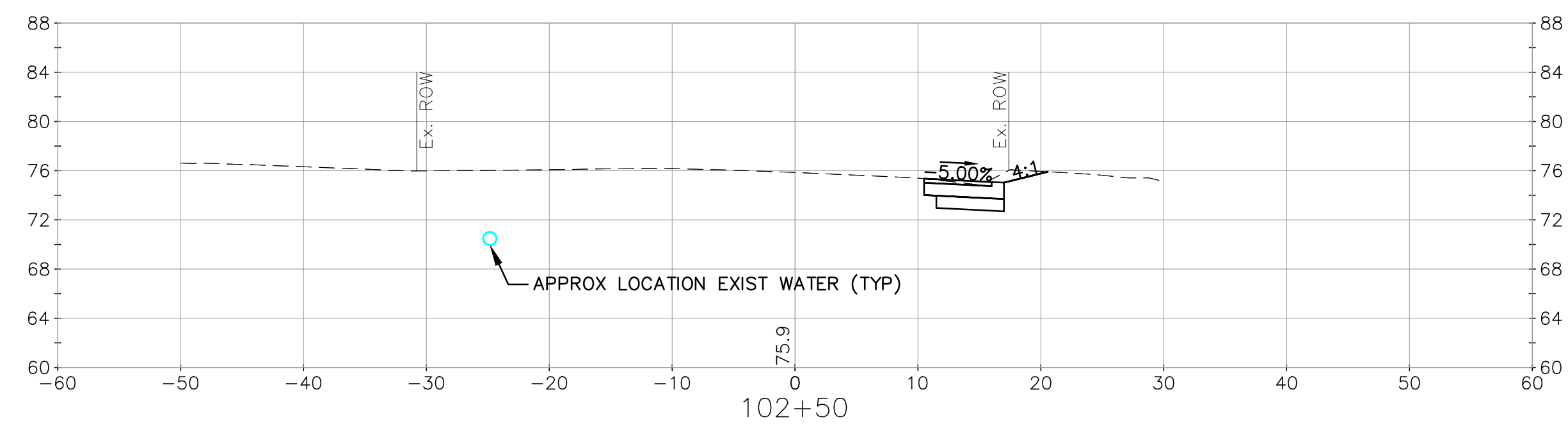
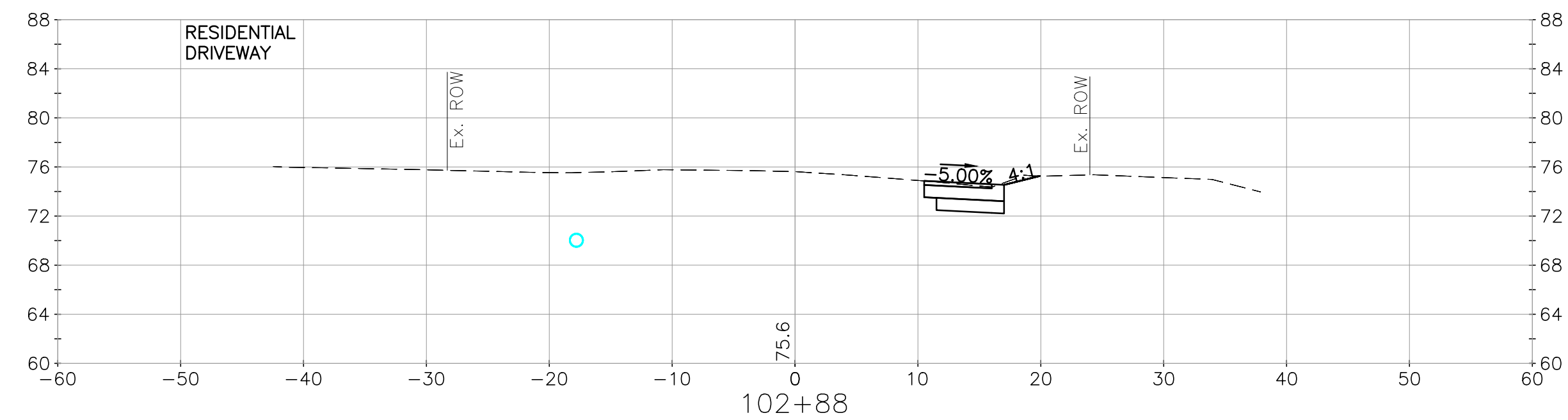
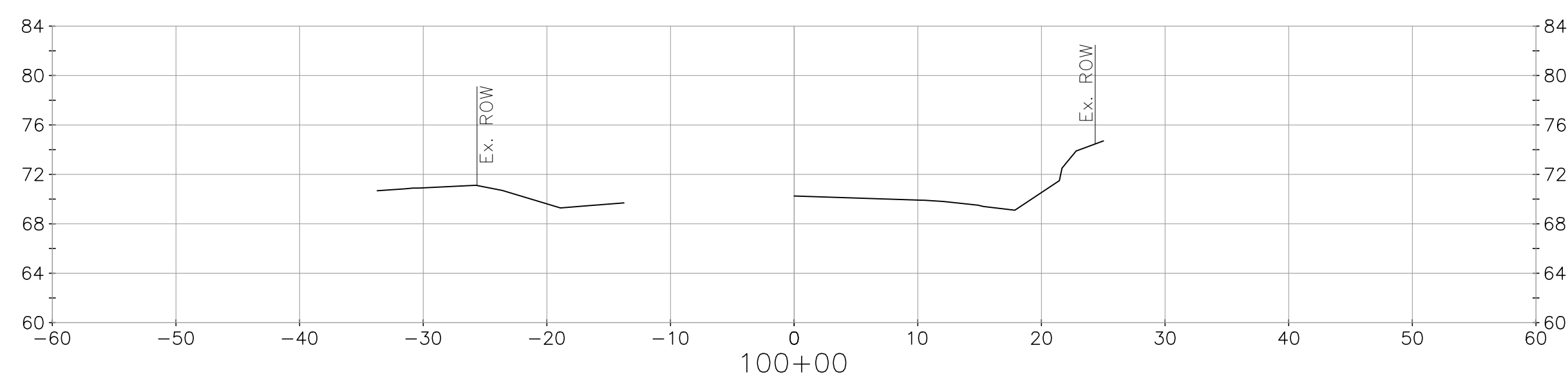
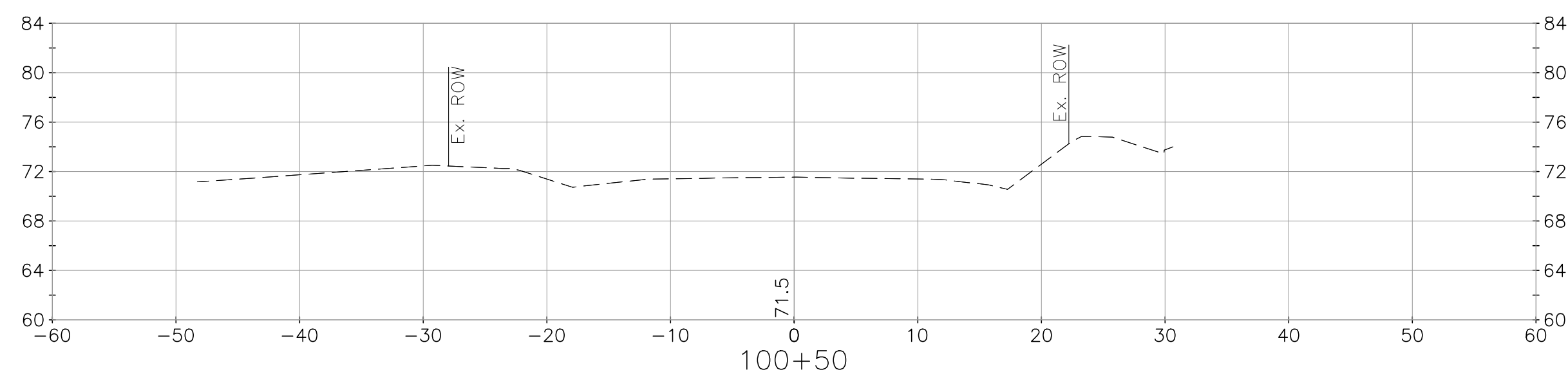
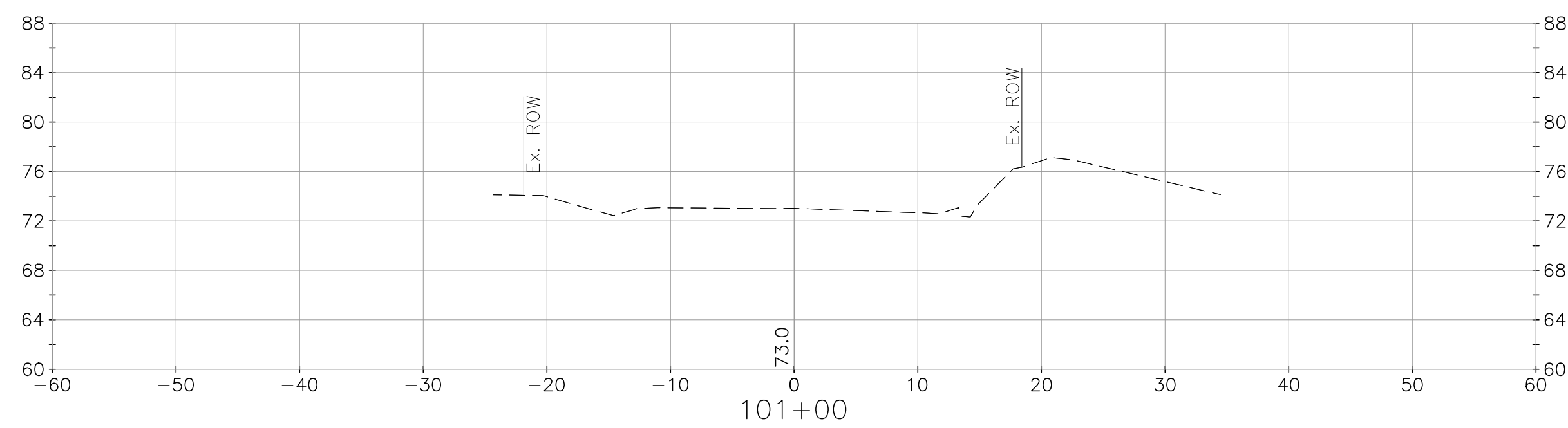
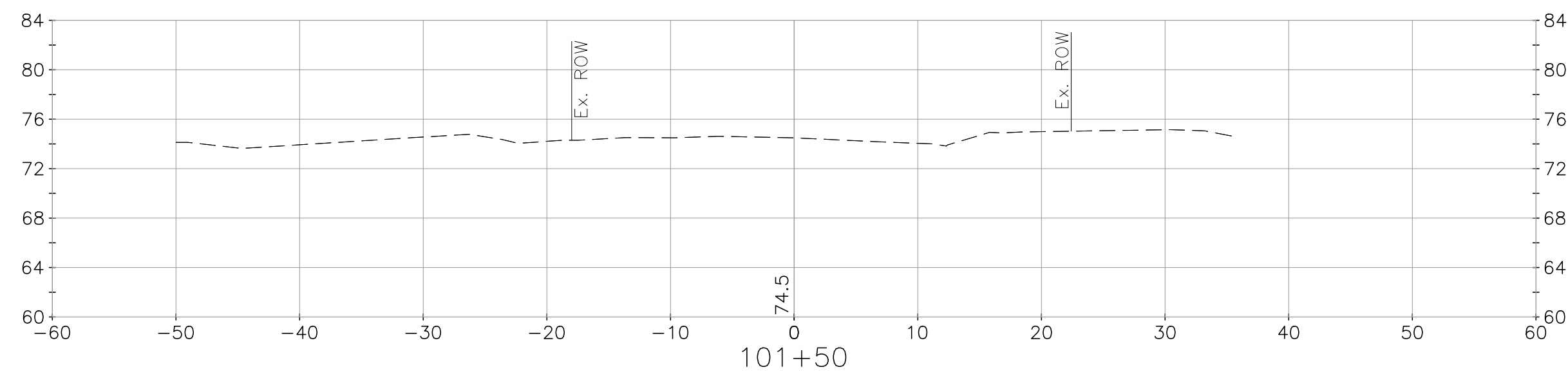

no.	1	Issued for Bidding	date	4/3/2023	by	JJB
revision						

CMA ENGINEERS
 CIVIL/ENVIRONMENTAL/STRUCTURAL
 Portsmouth, NH • Manchester, NH • Portland, ME
 603/431-6196 • 603/627-0708 • 207/541-4223
 c m a e n g i n e e r s . c o m

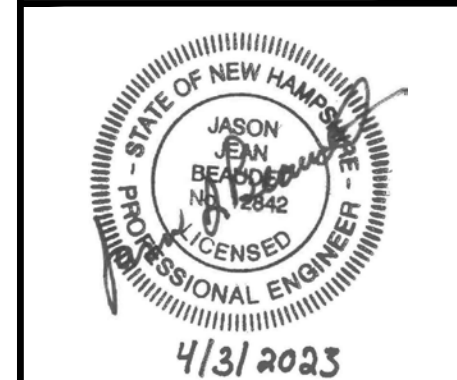

date:	April 2023	designed by:	JJB/STF
project no.:	1030	drawn by:	ATR/STF
file name:	1030-Sections.dwg	approved by:	JJB

scale: 1" = 10'
 0 10' 20'

Town of Exeter, New Hampshire
 Public Works Department
 Kingston Road TAP Project
 Exeter 40436, X-A004(406)
 Cross Sections
 STA 100+00 to STA 102+88

drawing no.
XS-1

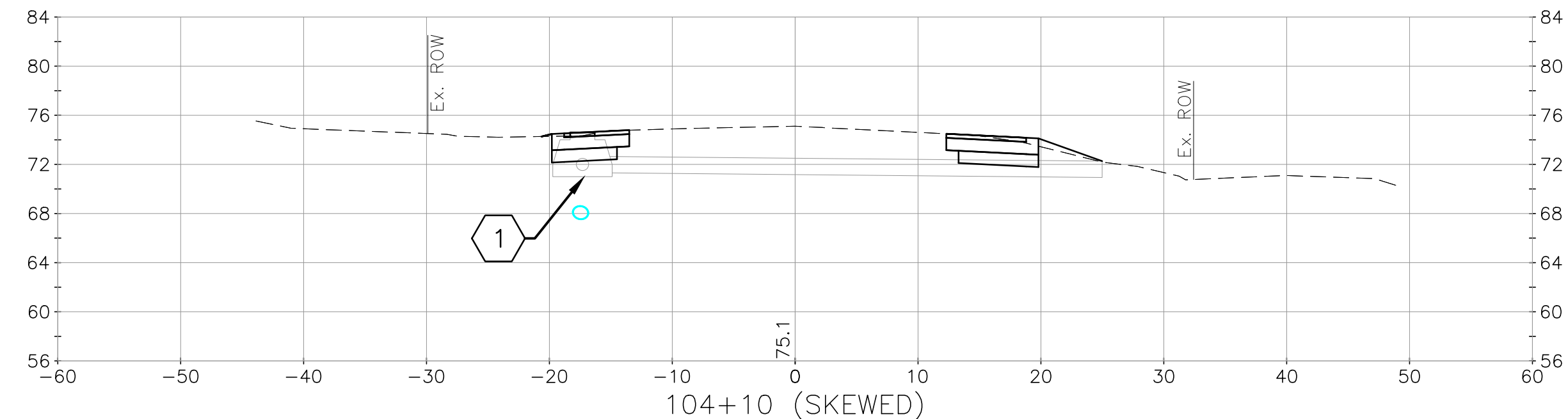
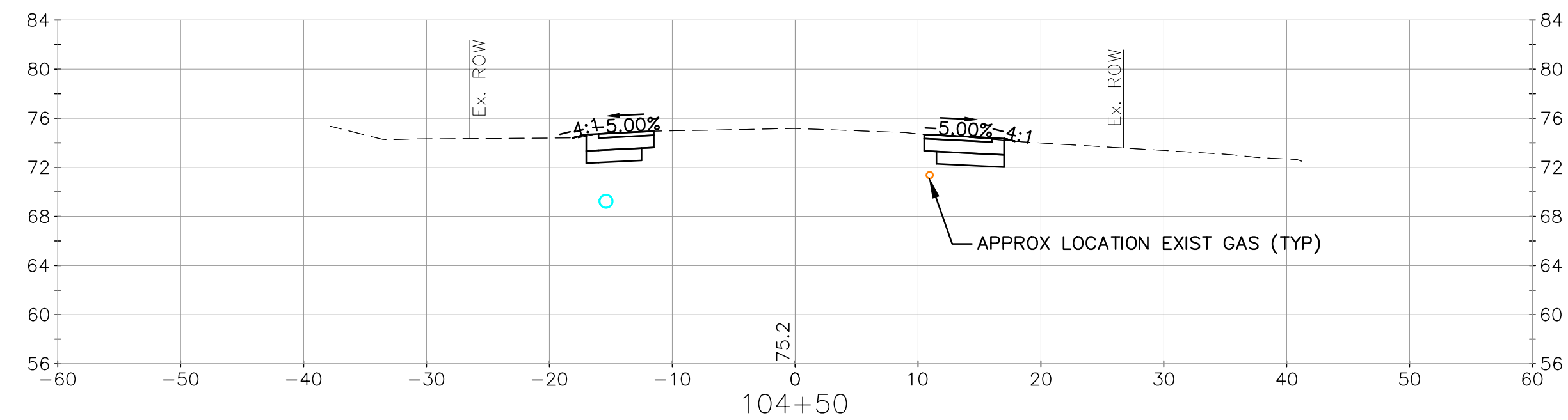
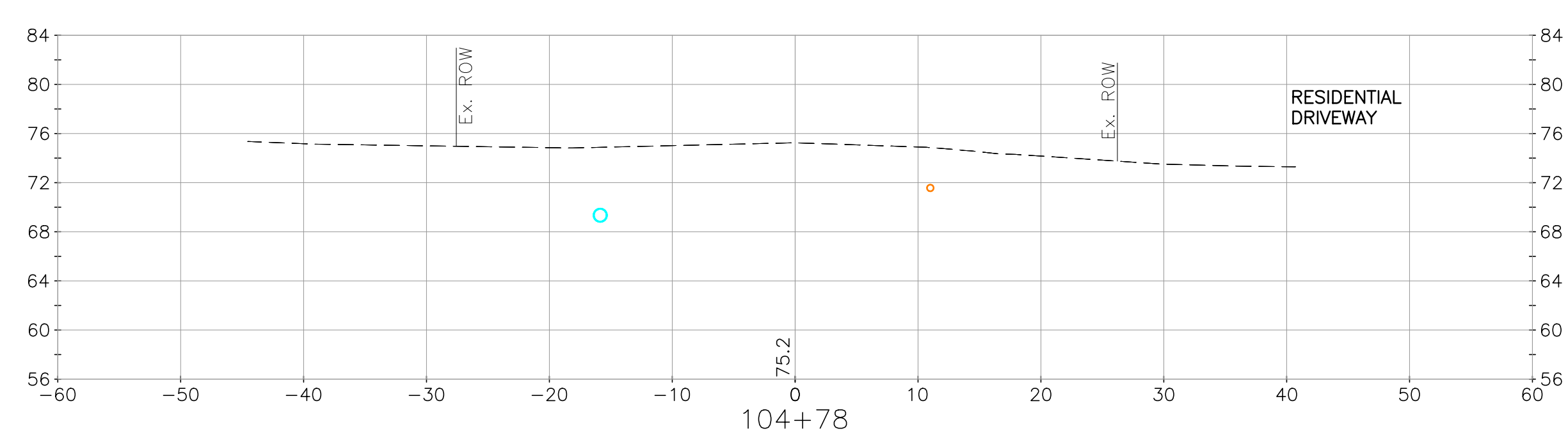
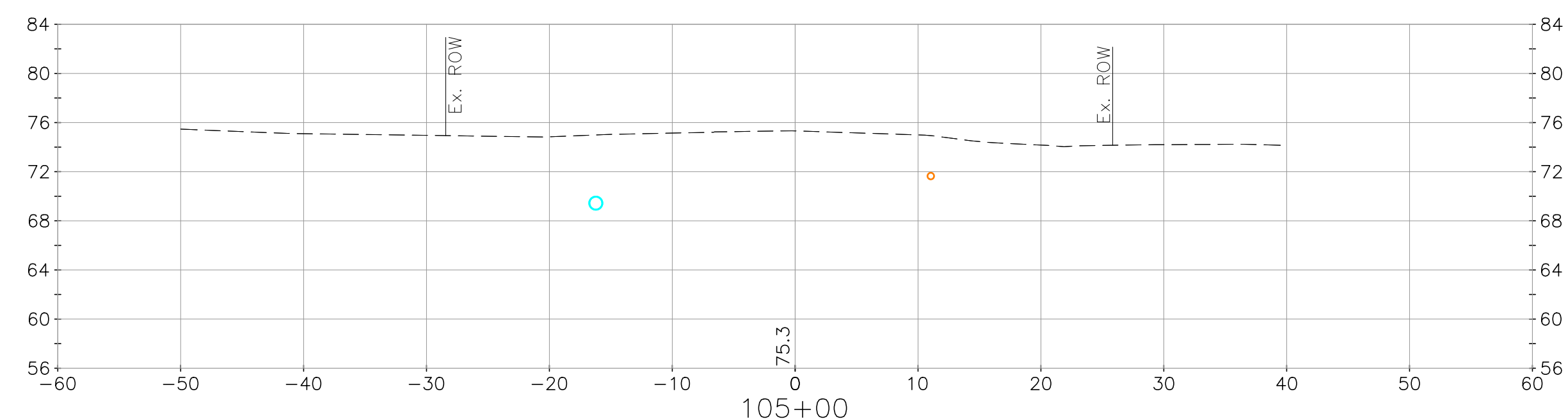
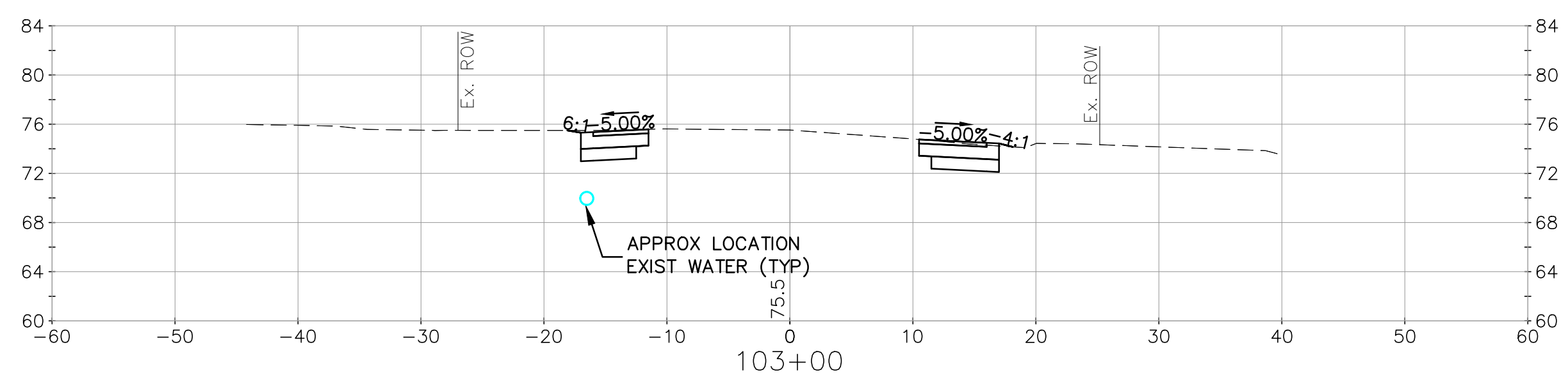
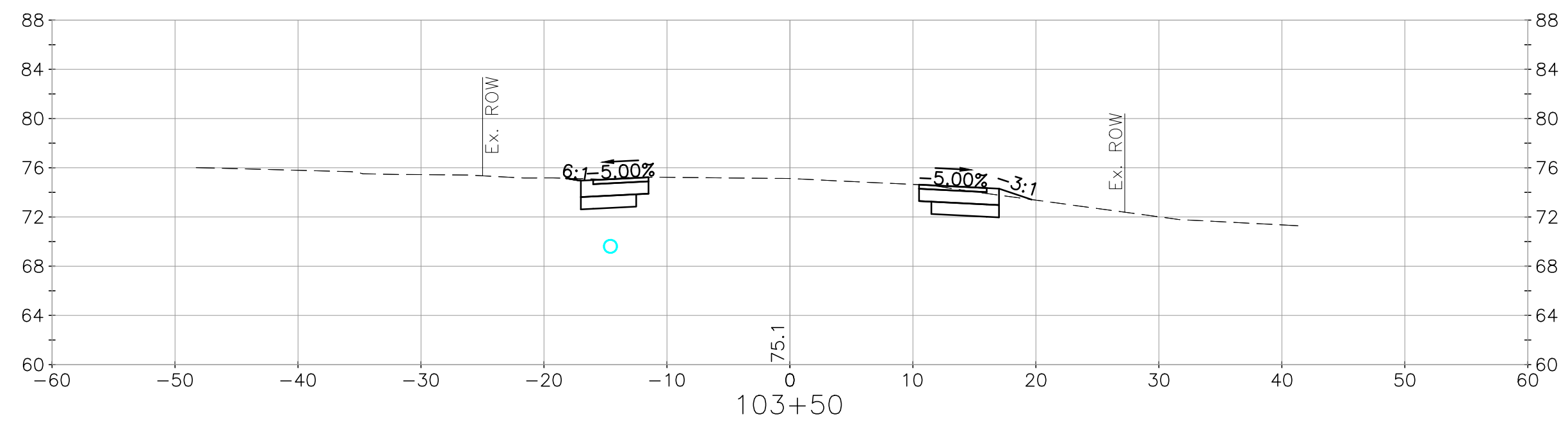
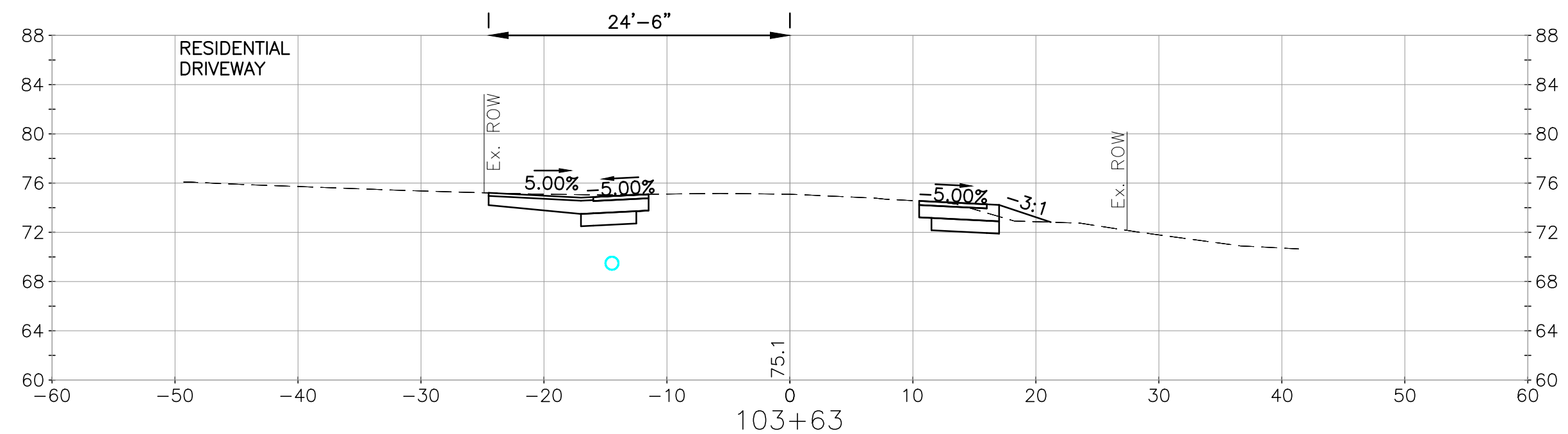
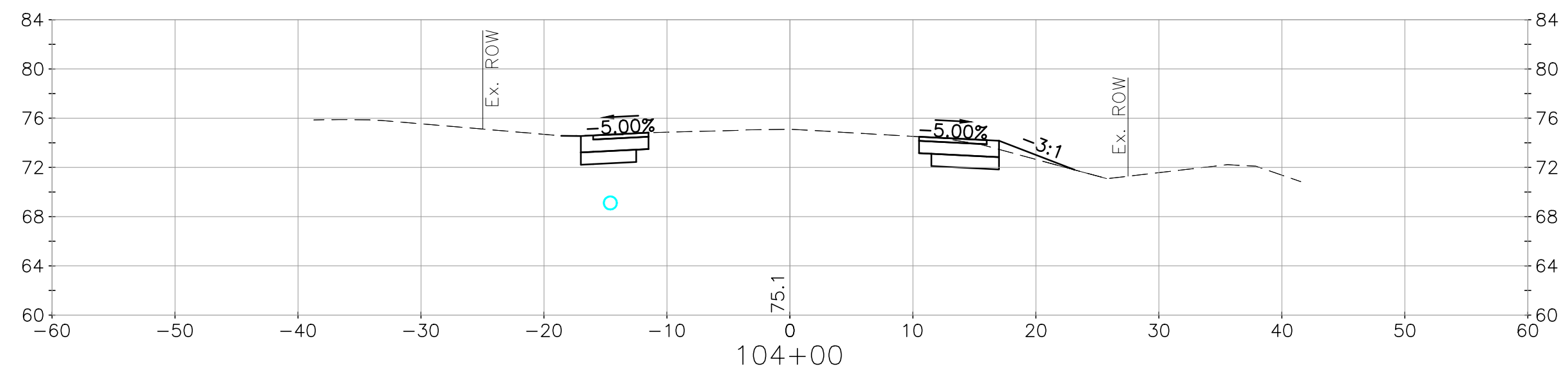

no.	1	Issued for Bidding	date	4/3/2023	JJB	by
revision						

CMA ENGINEERS
 CIVIL/ENVIRONMENTAL/STRUCTURAL
 Portsmouth, NH • Manchester, NH • Portland, ME
 603/431-6196 • 603/627-0708 • 207/541-4223
 c m a e n g i n e e r s . c o m

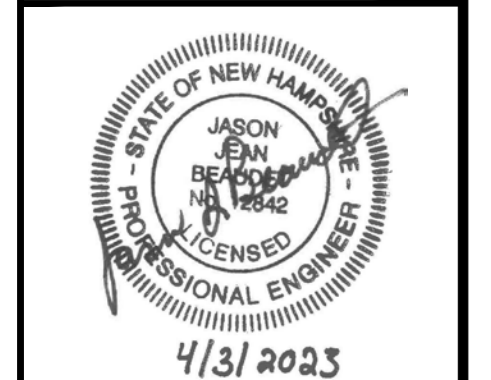

date:	April 2023	designed by:	JJB/STF
project no.:	1030	drawn by:	ATP/STF
file name:	1030-Sections.dwg	approved by:	JJB

Town of Exeter, New Hampshire
 Public Works Department
 Kingston Road TAP Project
 Exeter 40436, X-A004(406)
 Cross Sections
 STA 103+00 to STA 105+00

drawing no.	XS-2
sheet:	25 of 42

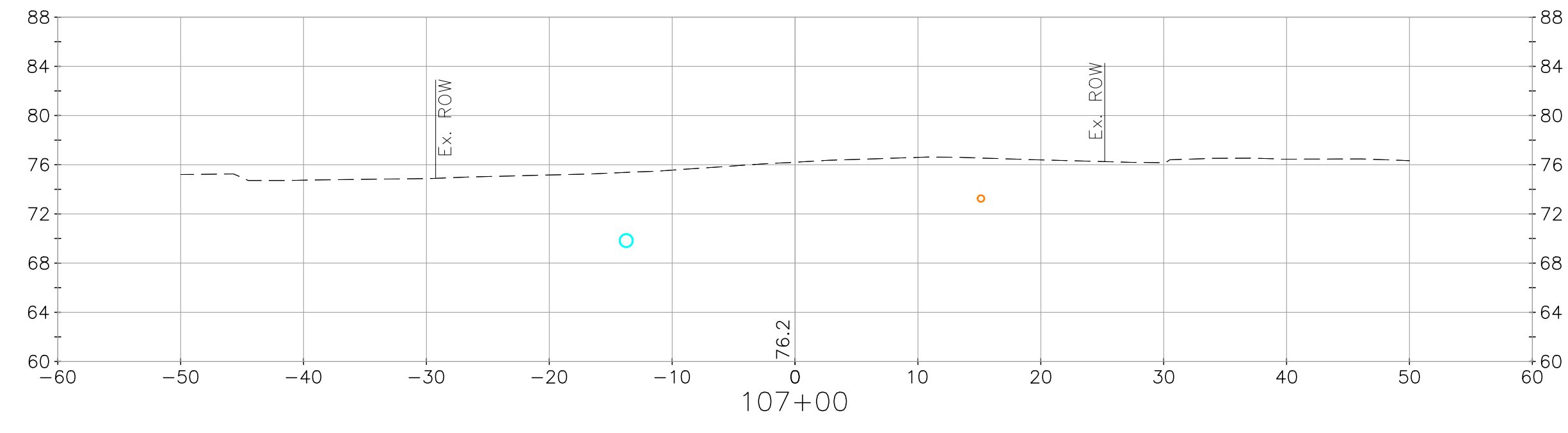
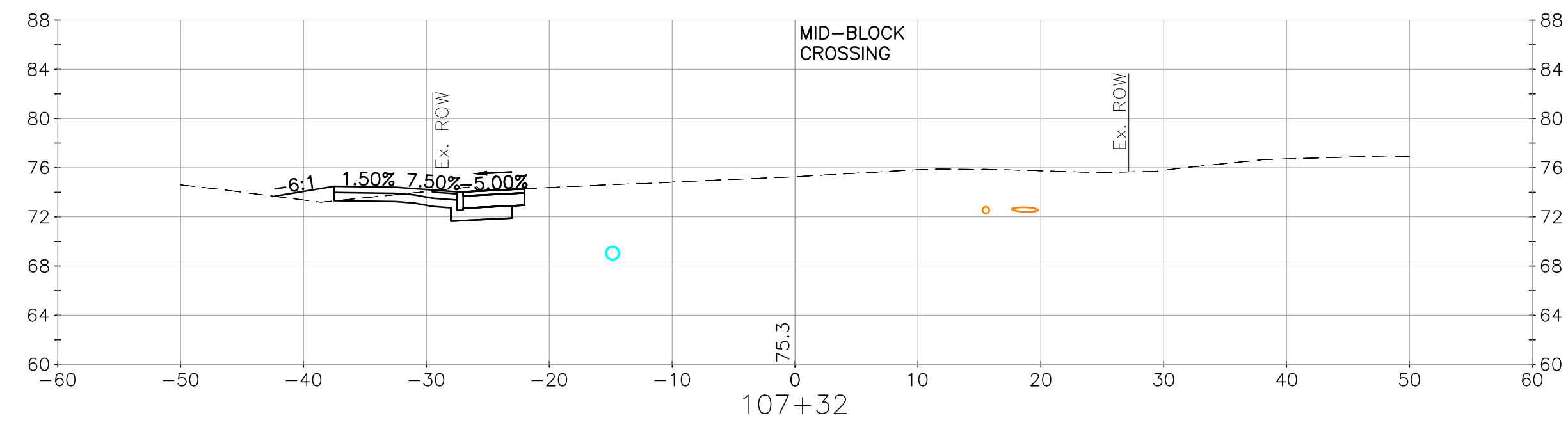
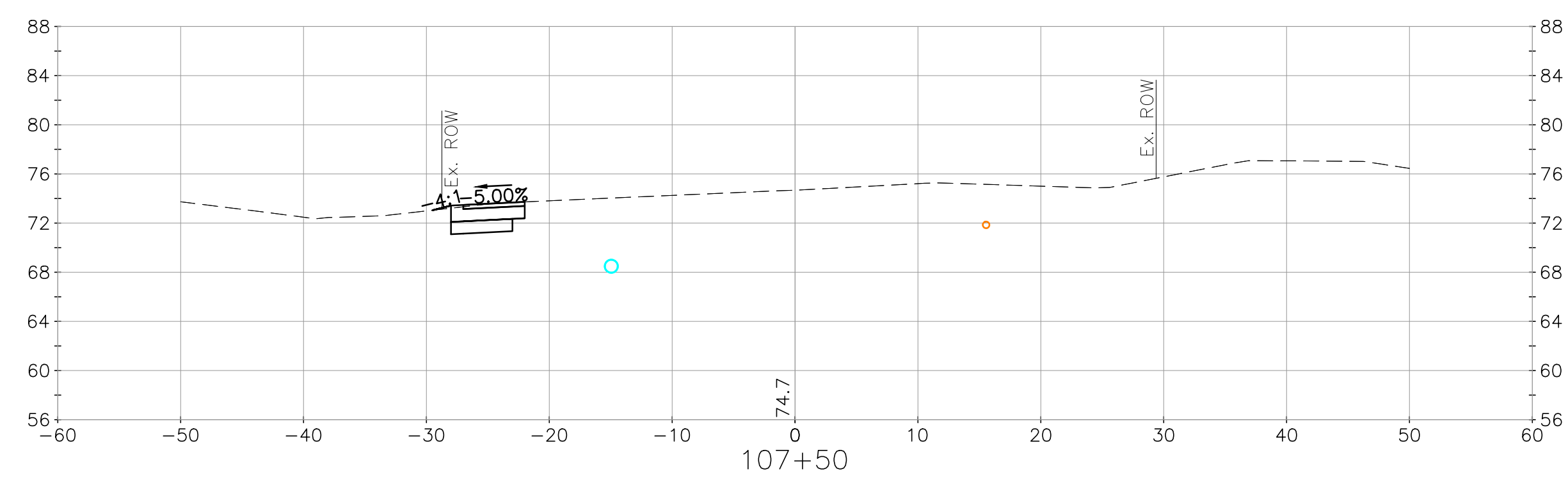
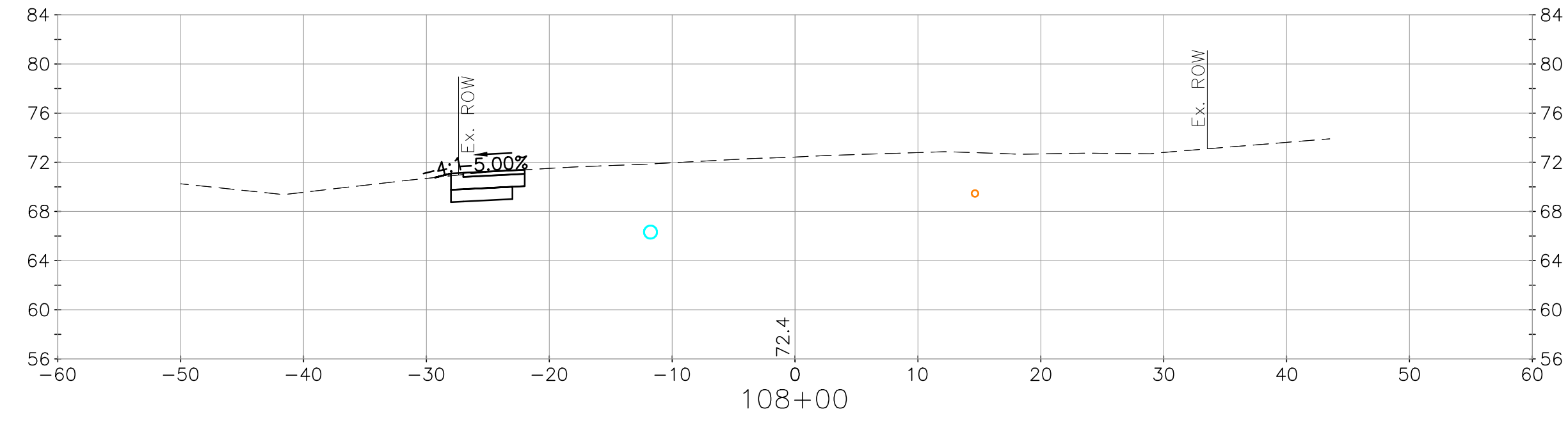
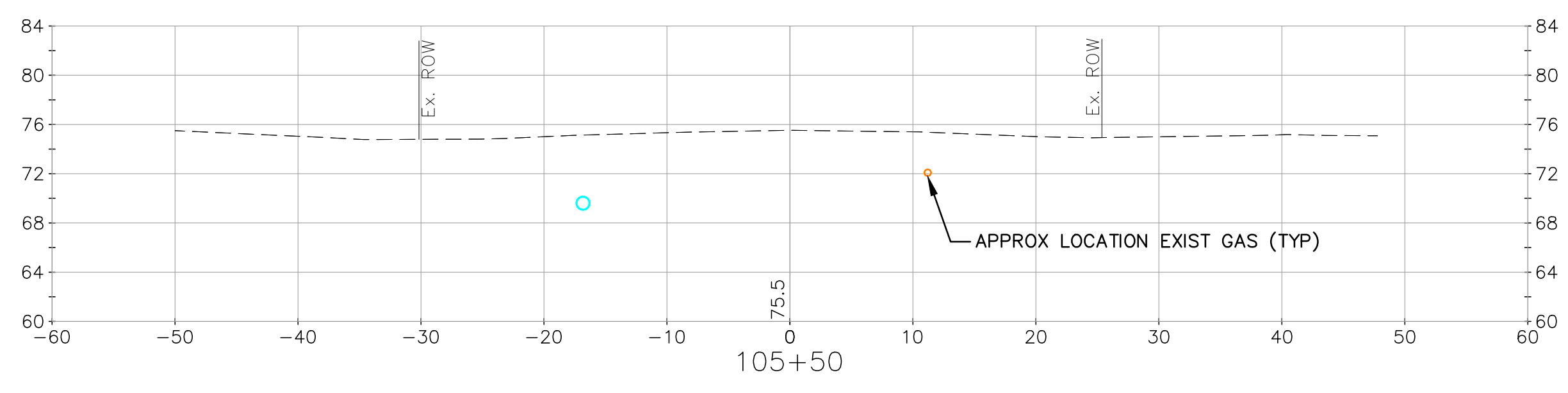
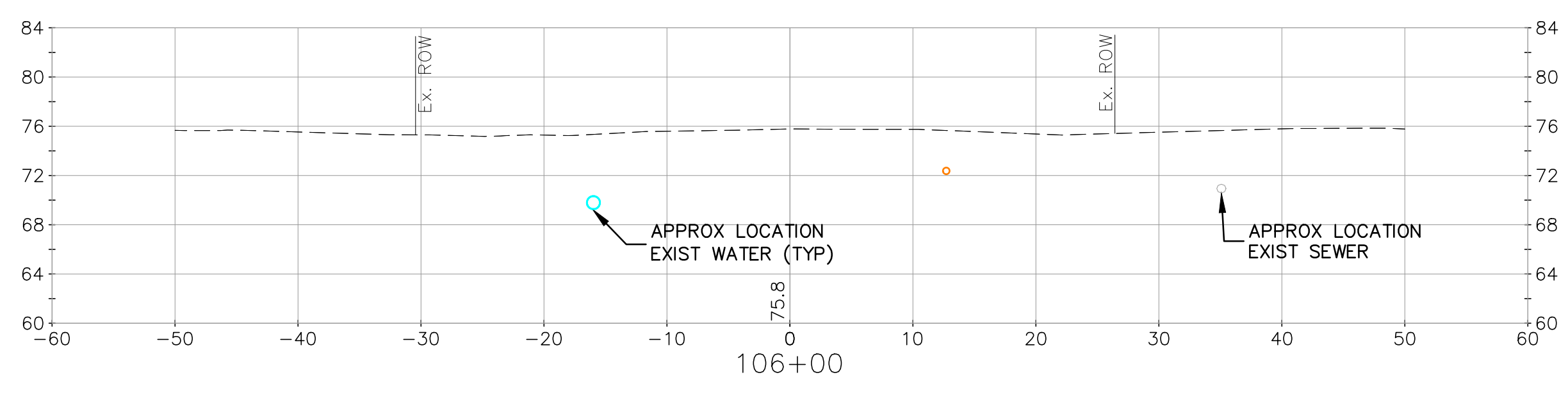
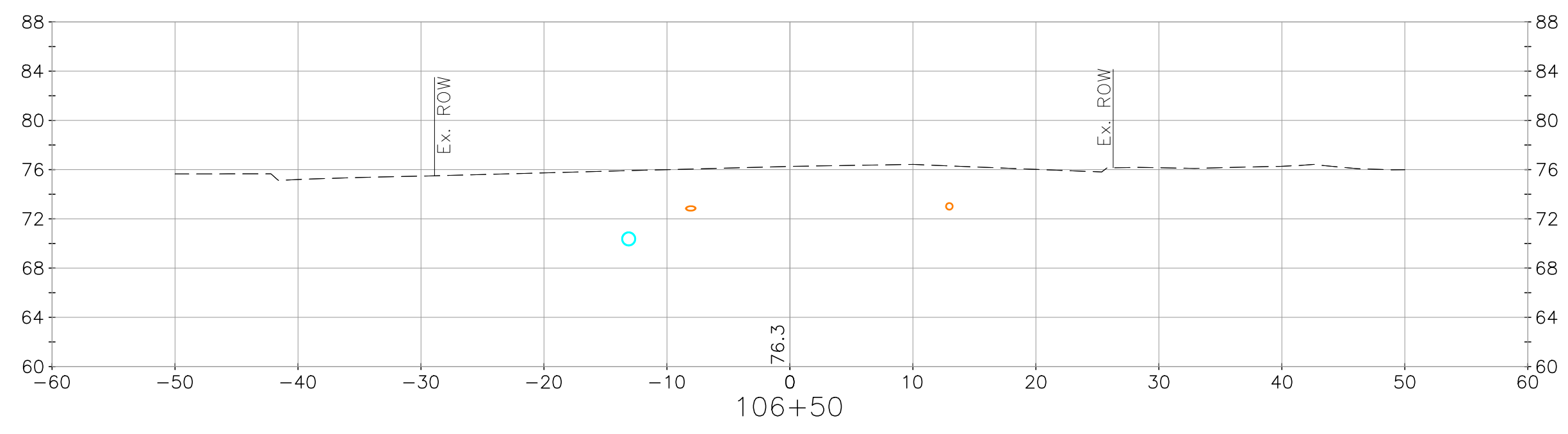
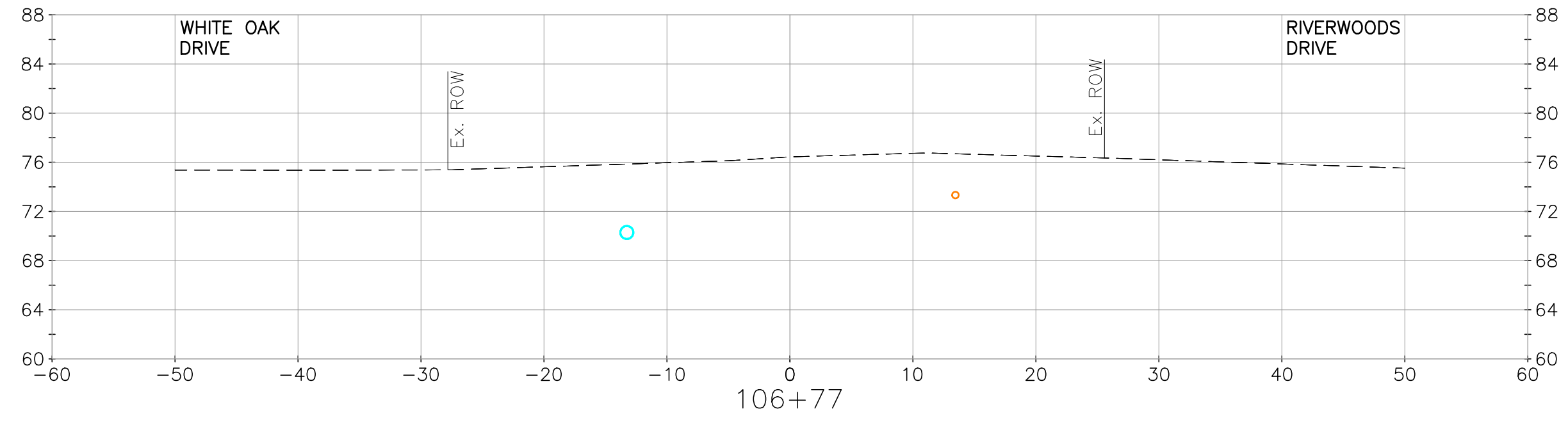

no.	1	revision	Issued for Bidding	date	4/3/2023	by	JJB
-----	---	----------	--------------------	------	----------	----	-----

CMA ENGINEERS
 CIVIL/ENVIRONMENTAL/STRUCTURAL
 Portsmouth, NH • Manchester, NH • Portland, ME
 603/431-6196 • 603/627-0708 • 207/541-4223
 c m a e n g i n e e r s . c o m

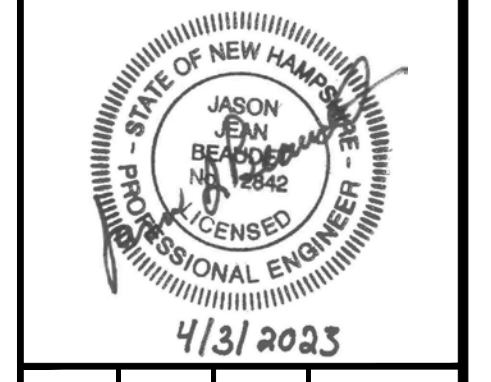

date:	April 2023	designed by:	JJB/STF
project no.:	1030	drawn by:	ATP/STF
file name:	1030-Sections.dwg	approved by:	JJB

scale: 1" = 10'
 0 10' 20'

Town of Exeter, New Hampshire
 Public Works Department
 Kingston Road TAP Project
 Exeter 40436, X-A004(406)
 Cross Sections
 STA 105+50 to STA 108+00

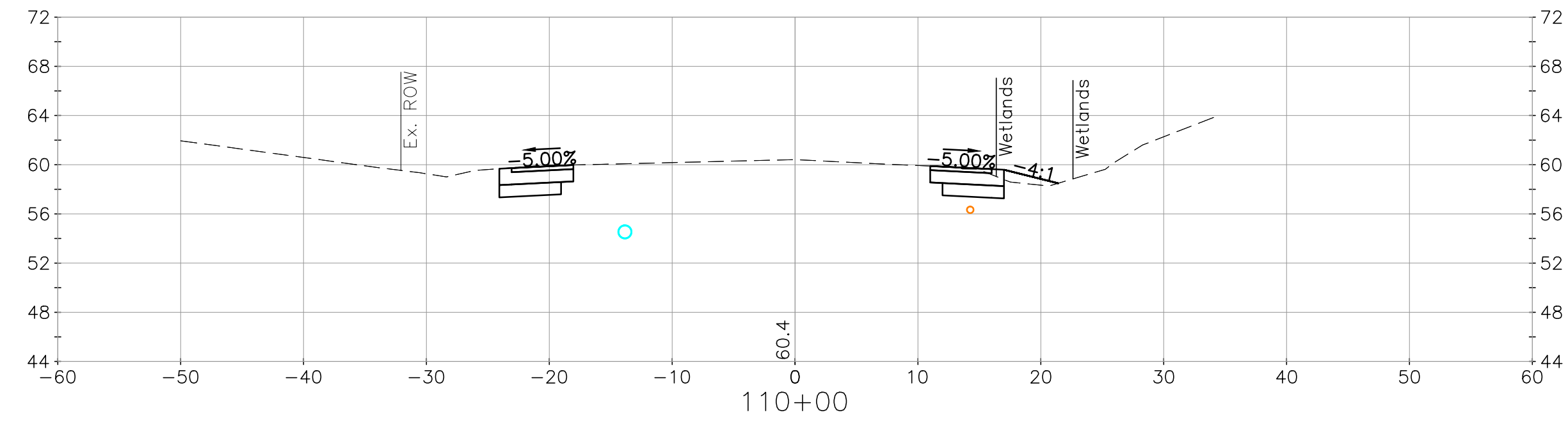
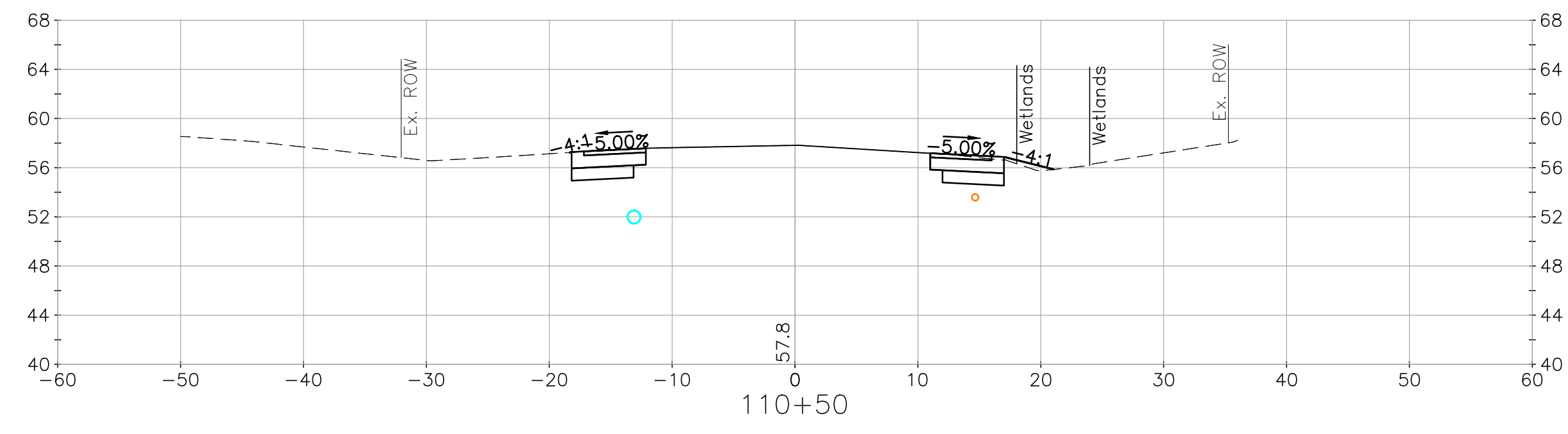
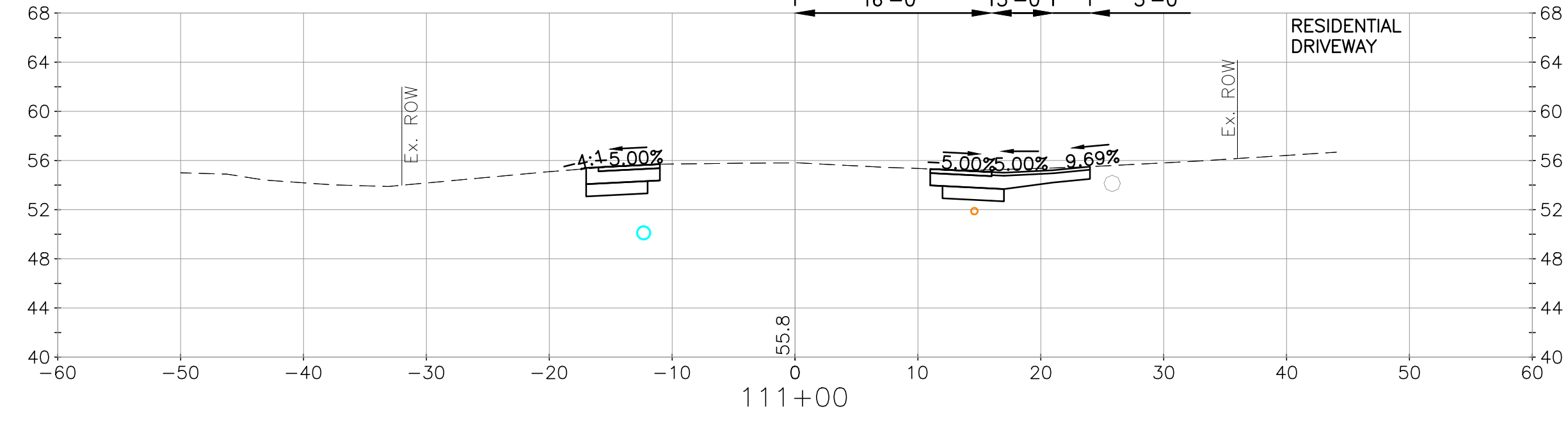
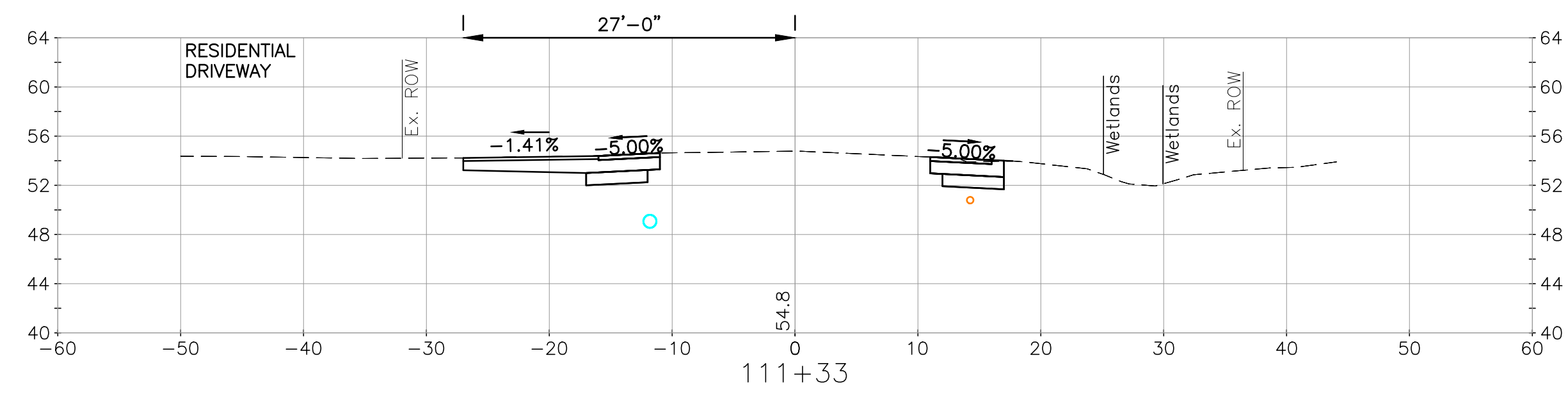
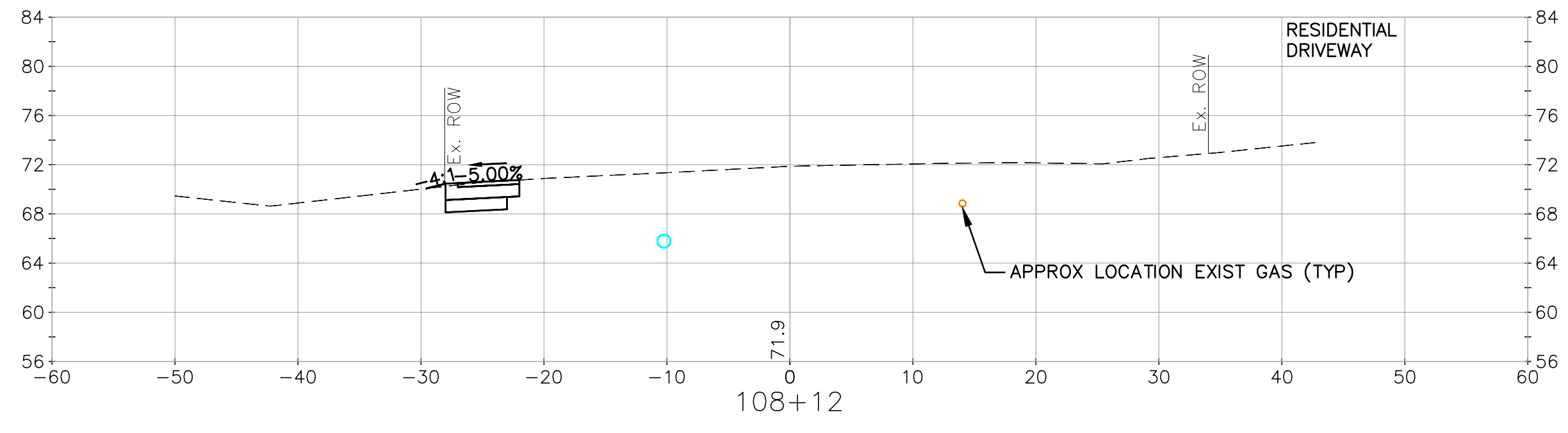
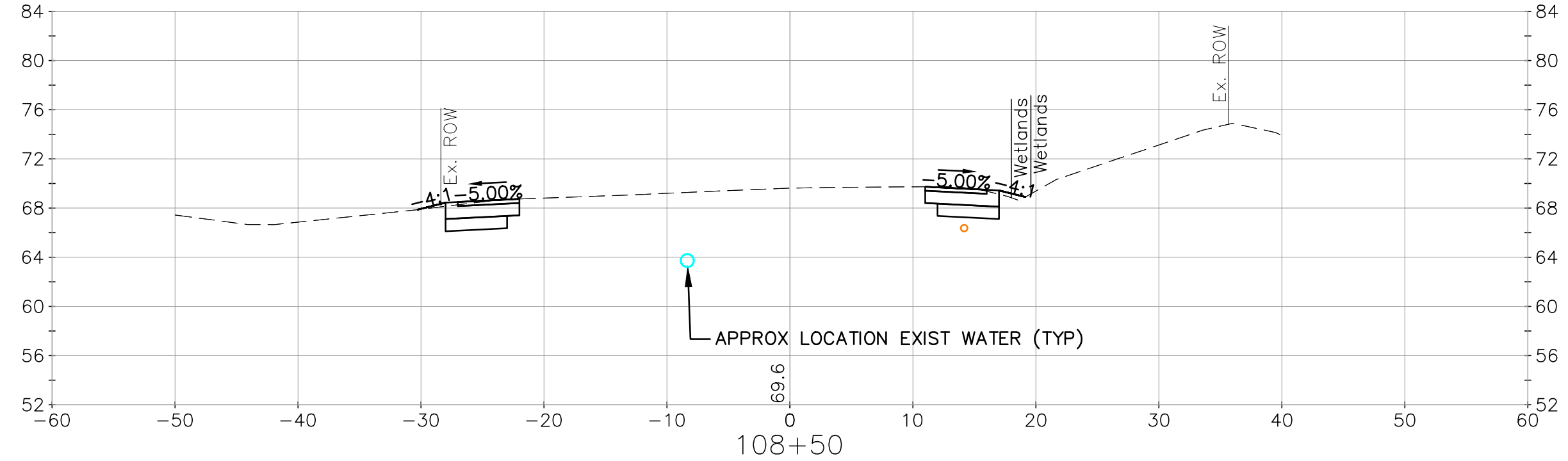
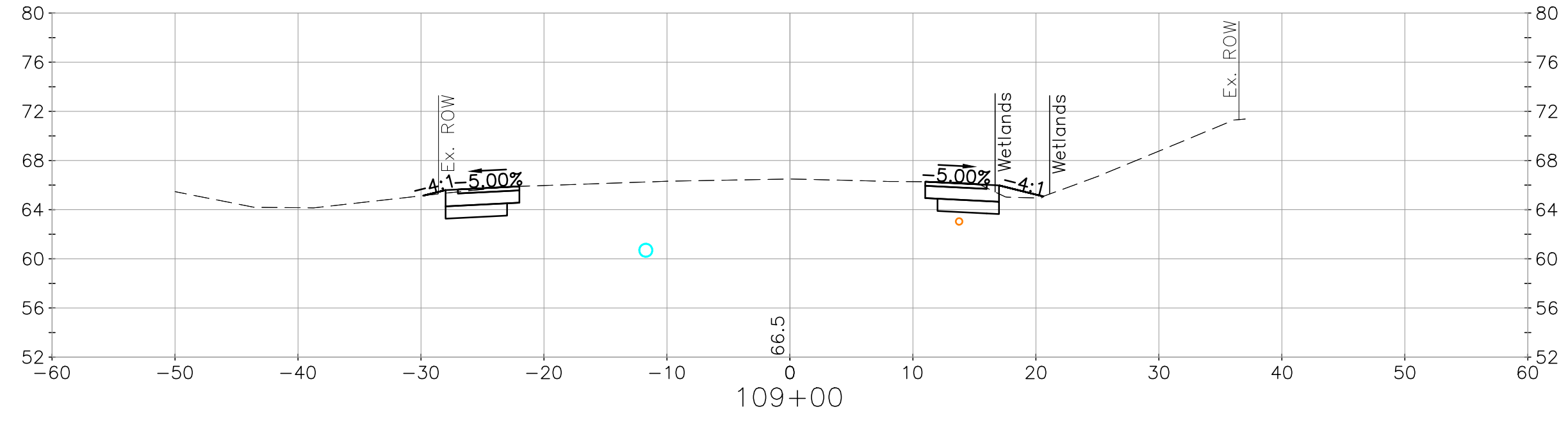
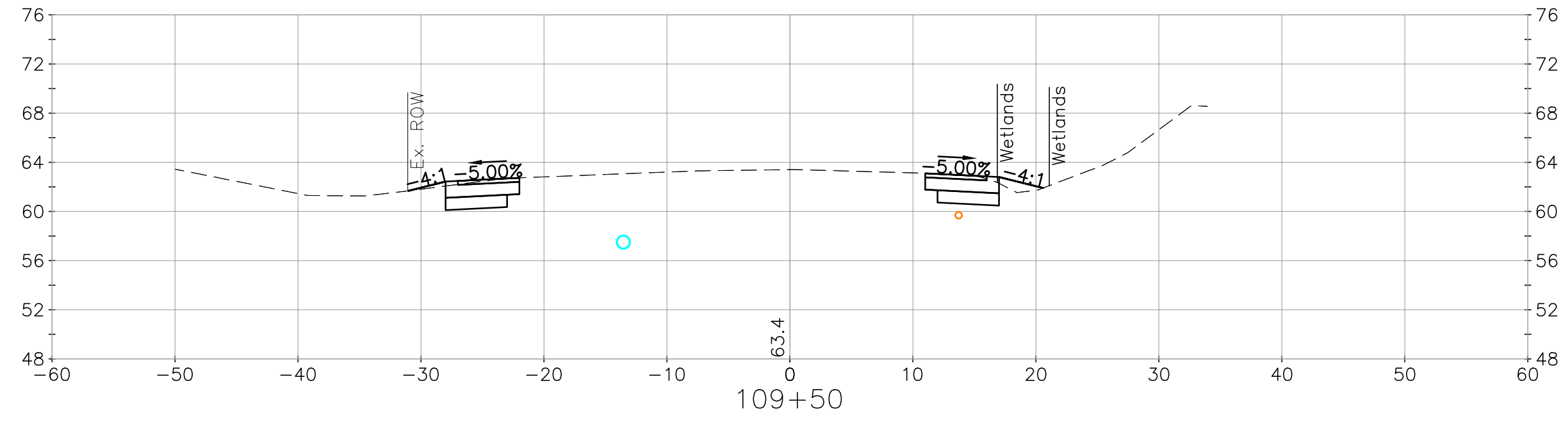

no.	1	Issued for Bidding	4/3/2023	JJB
revision			date	by

CMA ENGINEERS
 CIVIL/ENVIRONMENTAL/STRUCTURAL
 Portsmouth, NH • Manchester, NH • Portland, ME
 603/431-6196 • 603/627-0708 • 207/541-4223
 c m a e n g i n e e r s . c o m

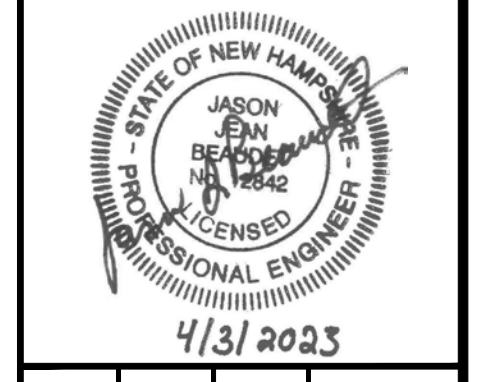

date:	April 2023	designed by:	JJB/STF
project no.:	1030	drawn by:	ATR/STF
file name:	1030-Sections.dwg	approved by:	JJB

scale: 1" = 10'
 0 10' 20'

Town of Exeter, New Hampshire
 Public Works Department
 Kingston Road TAP Project
 Exeter 40436, X-A004(406)
 Cross Sections
 STA 108+12 to STA 111+33

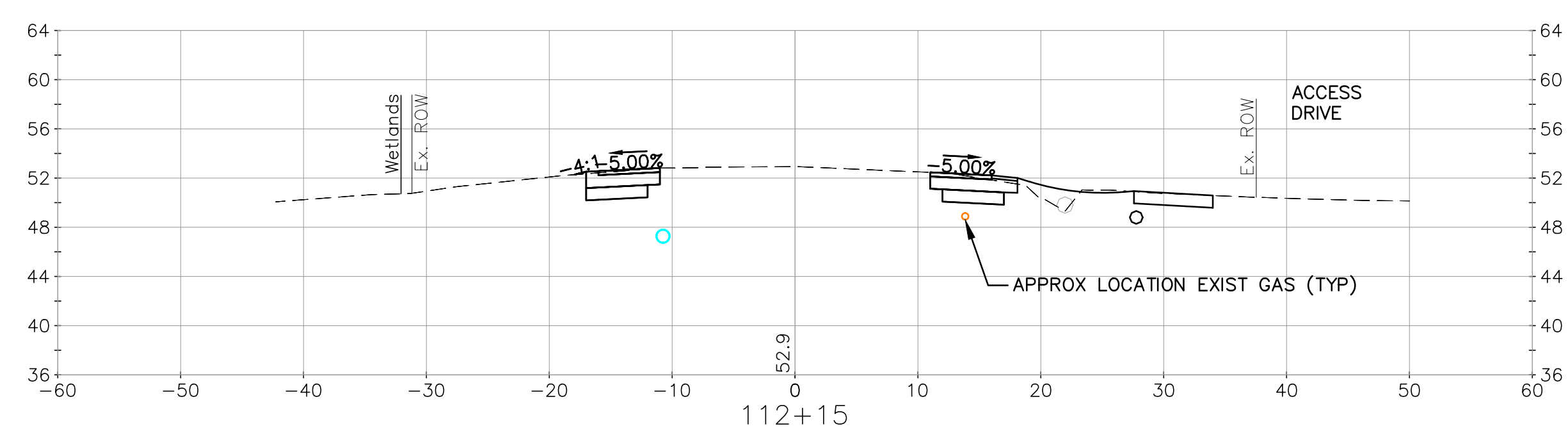
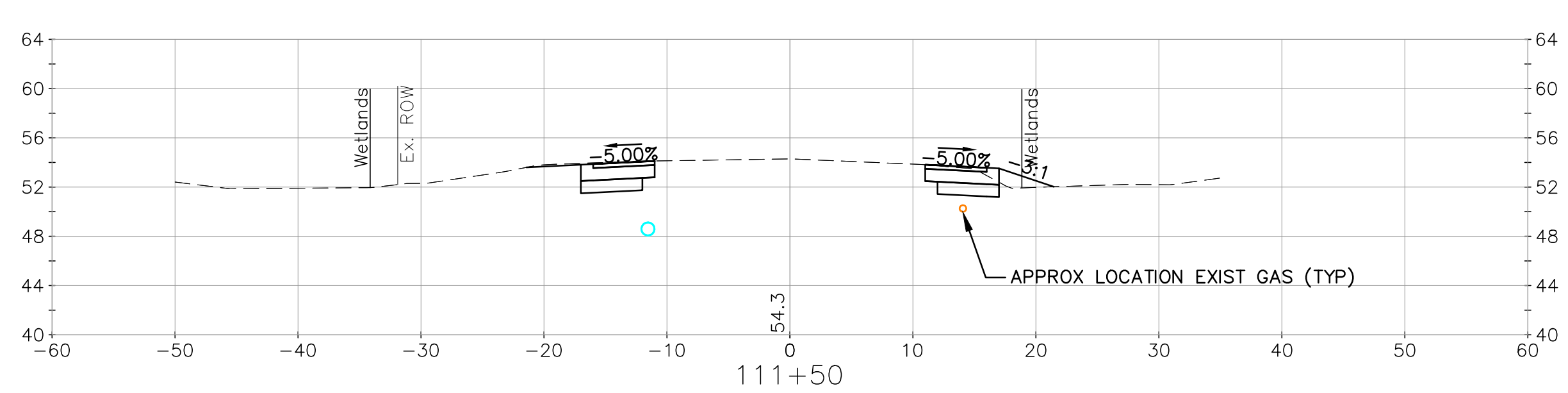
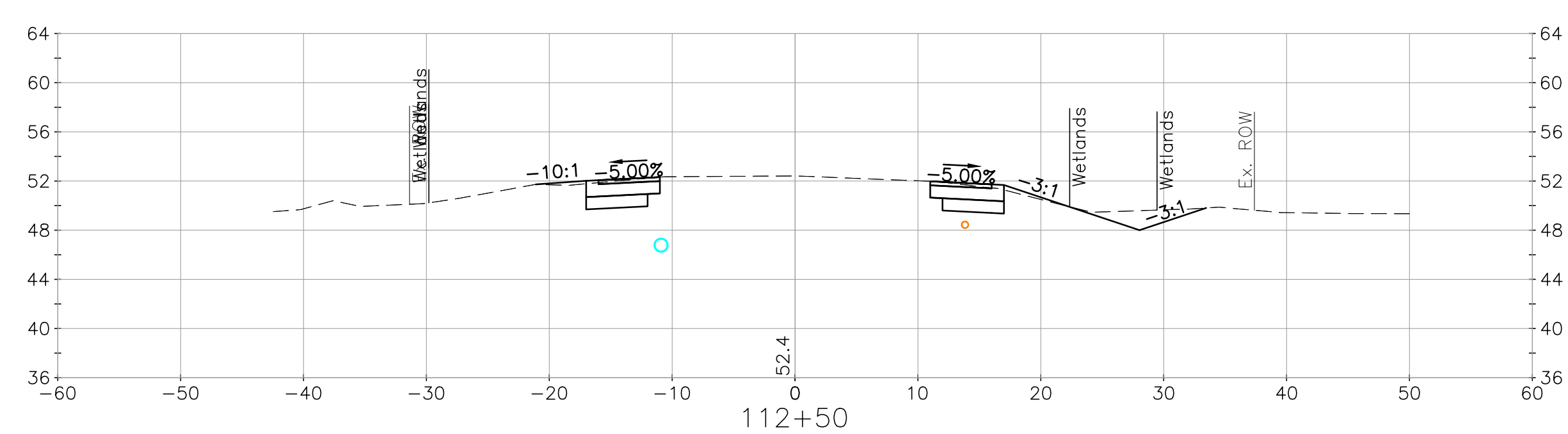
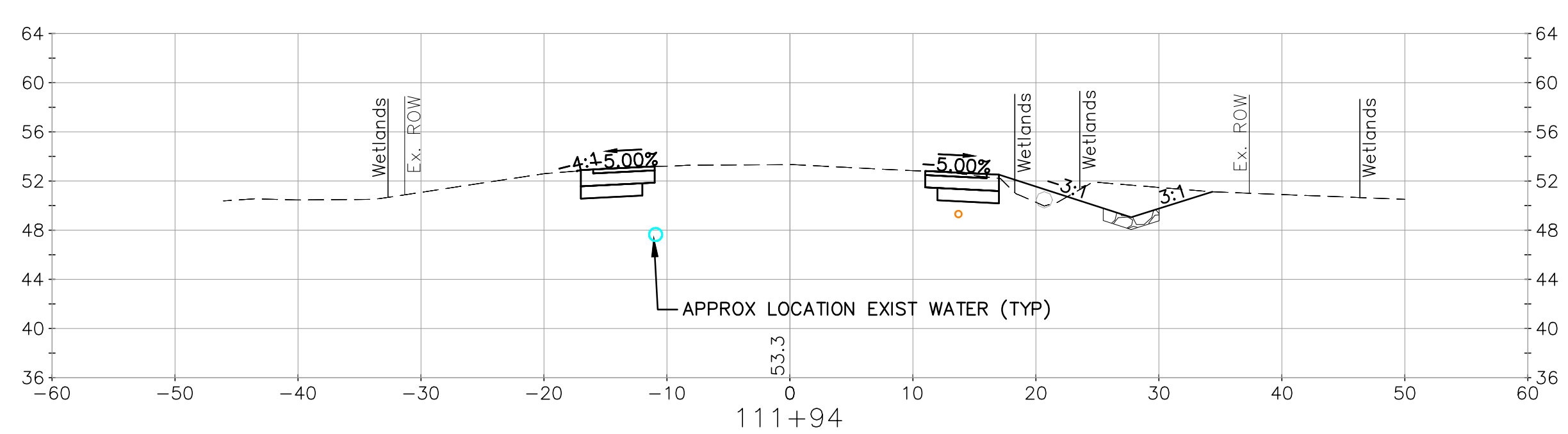
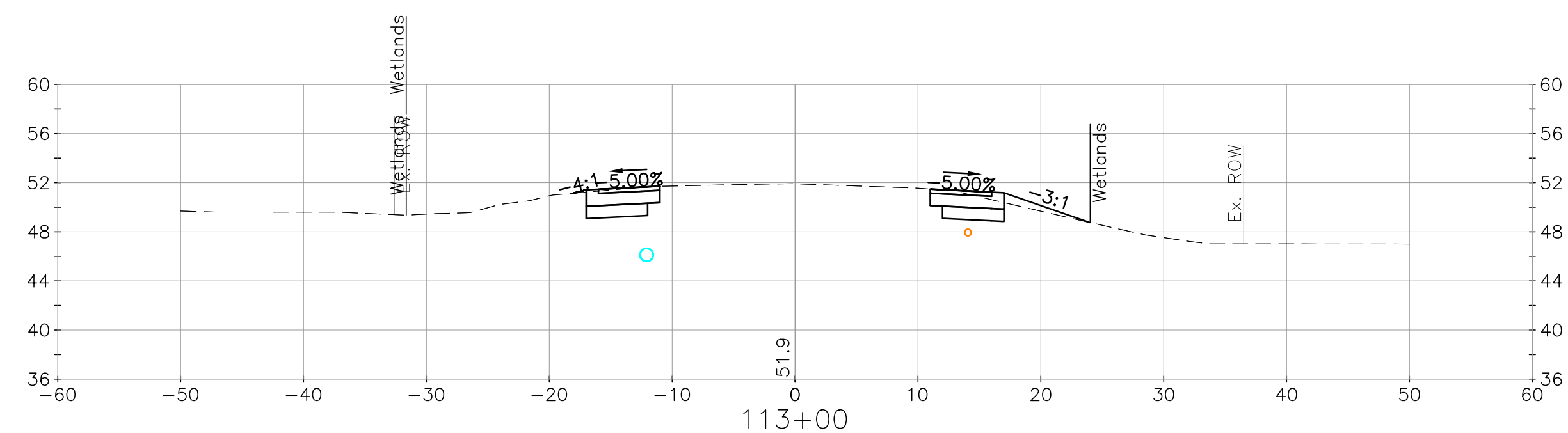
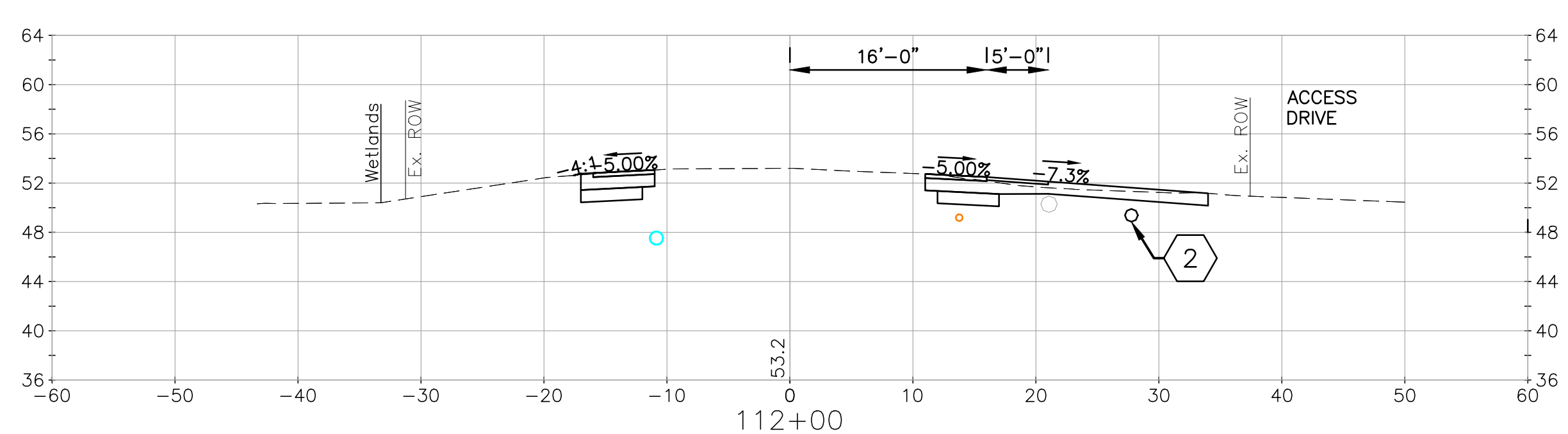
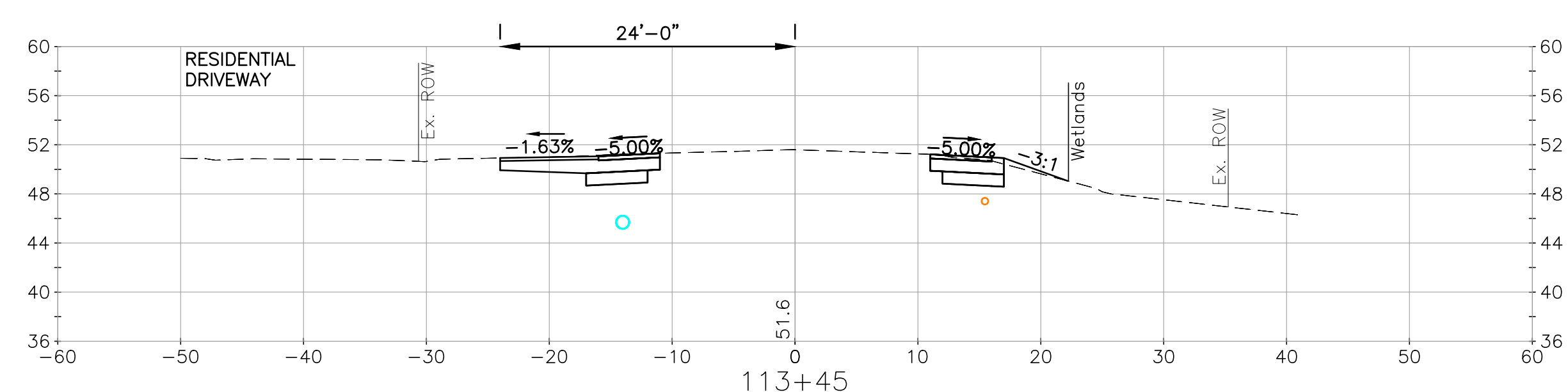
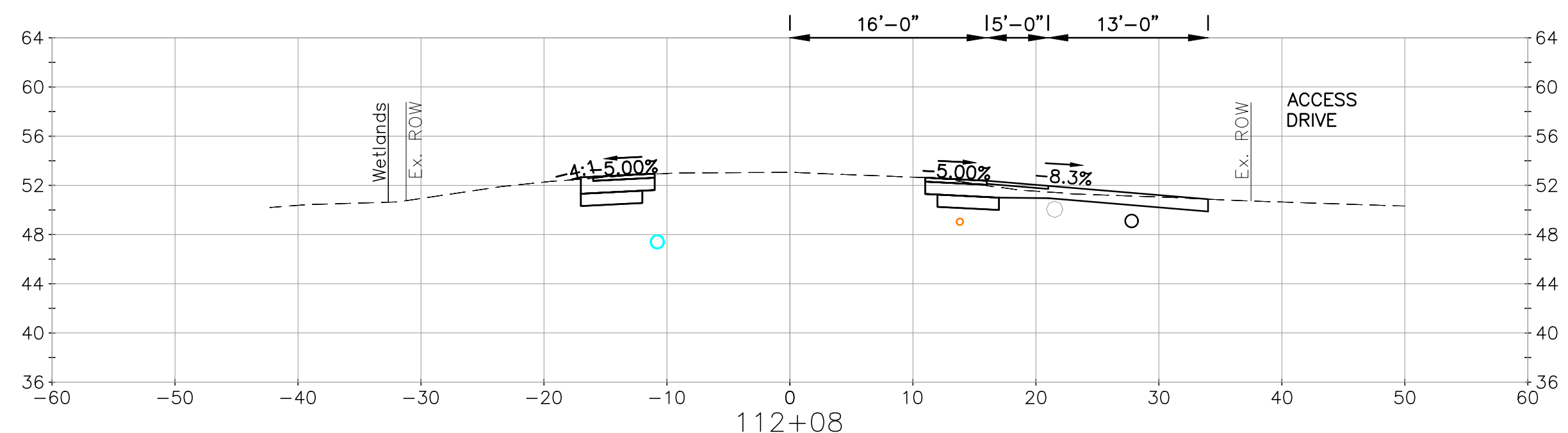

no.	1	Issued for Bidding	date	4/3/2023	JUB	by
-----	---	--------------------	------	----------	-----	----

CMA ENGINEERS
 CIVIL/ENVIRONMENTAL/STRUCTURAL
 Portsmouth, NH • 603/431-6196
 Manchester, NH • 603/627-0708
 Portland, ME • 207/541-4223
 c m a e n g i n e e r s . c o m

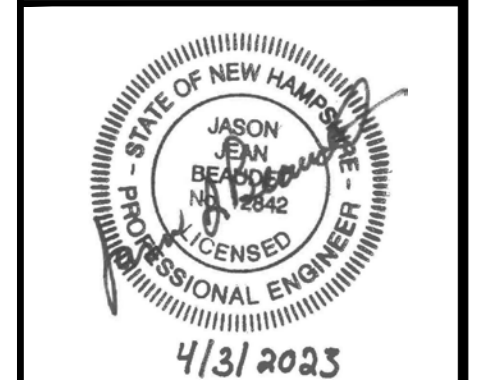

date:	April 2023	designed by:	JUB/STF
project no.:	1030	drawn by:	ATP/STF
file name:	1030-Sections.dwg	approved by:	JUB

Scale: 1" = 10'
 0 10' 20'

Town of Exeter, New Hampshire
 Public Works Department
 Kingston Road TAP Project
 Exeter 40436, X-A004(406)
 Cross Sections
 STA 111+50 to STA 113+45

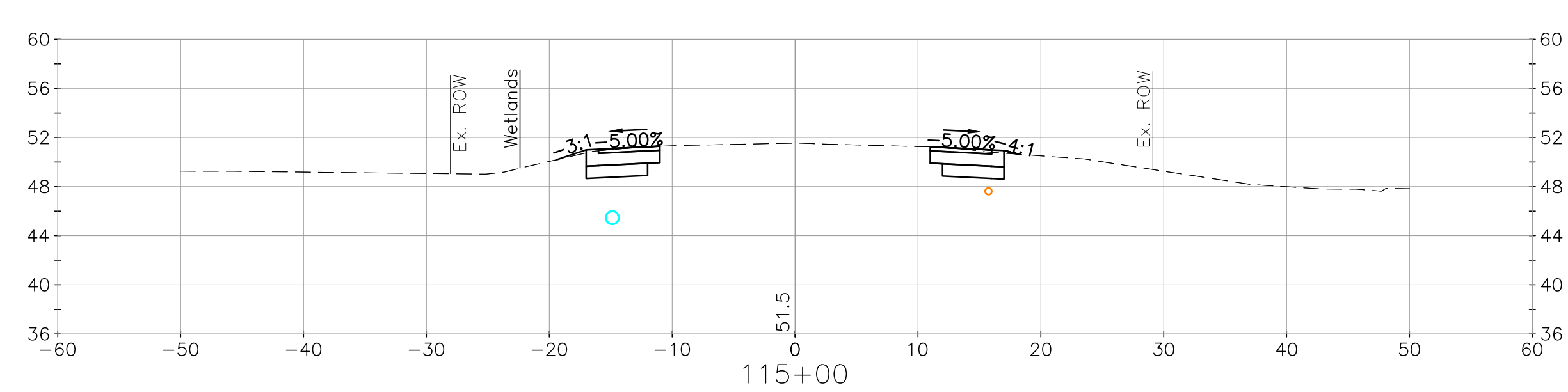
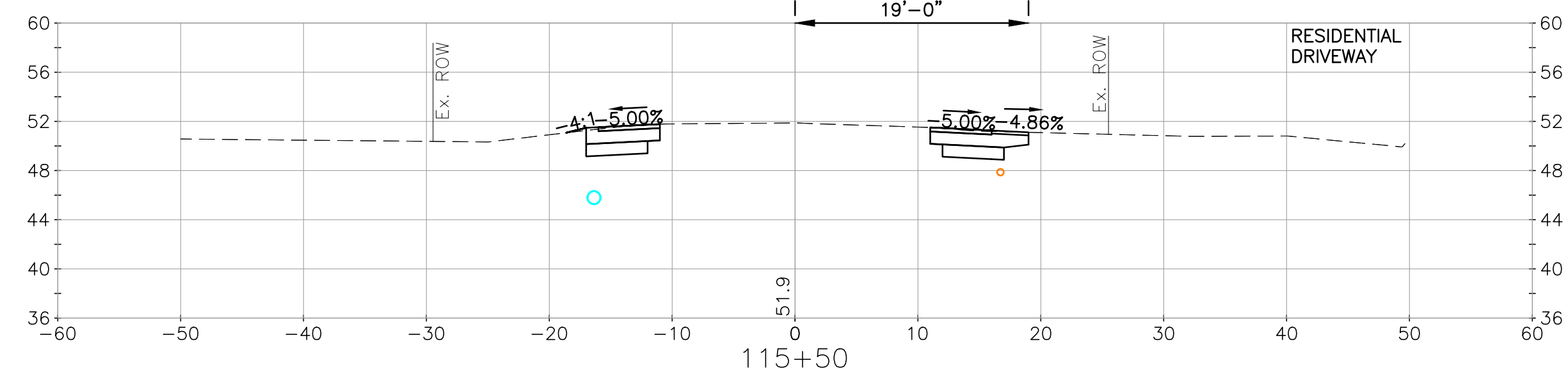
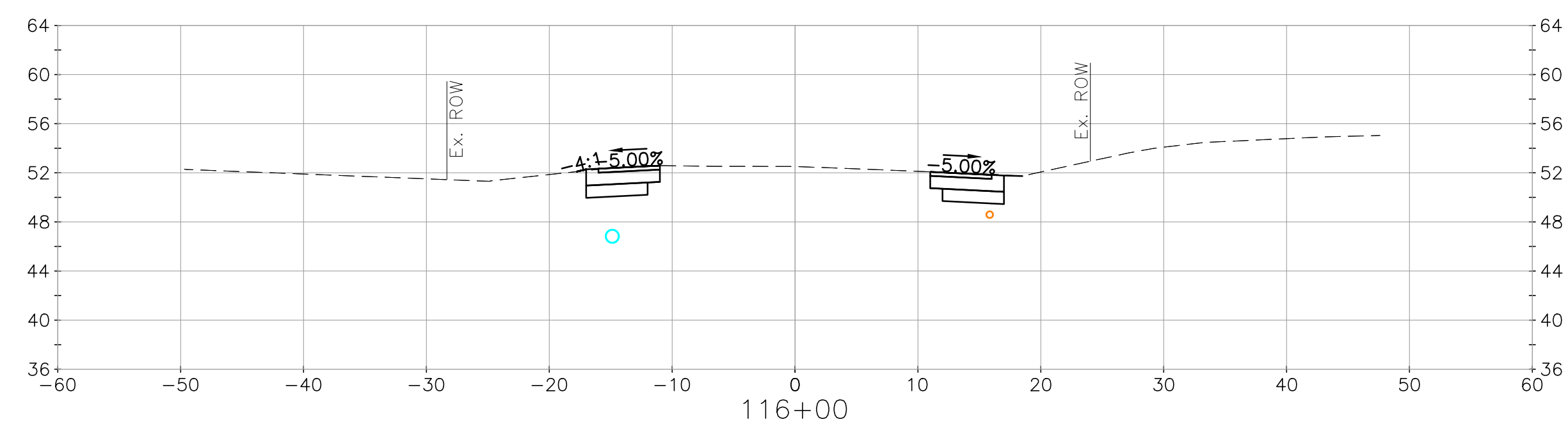
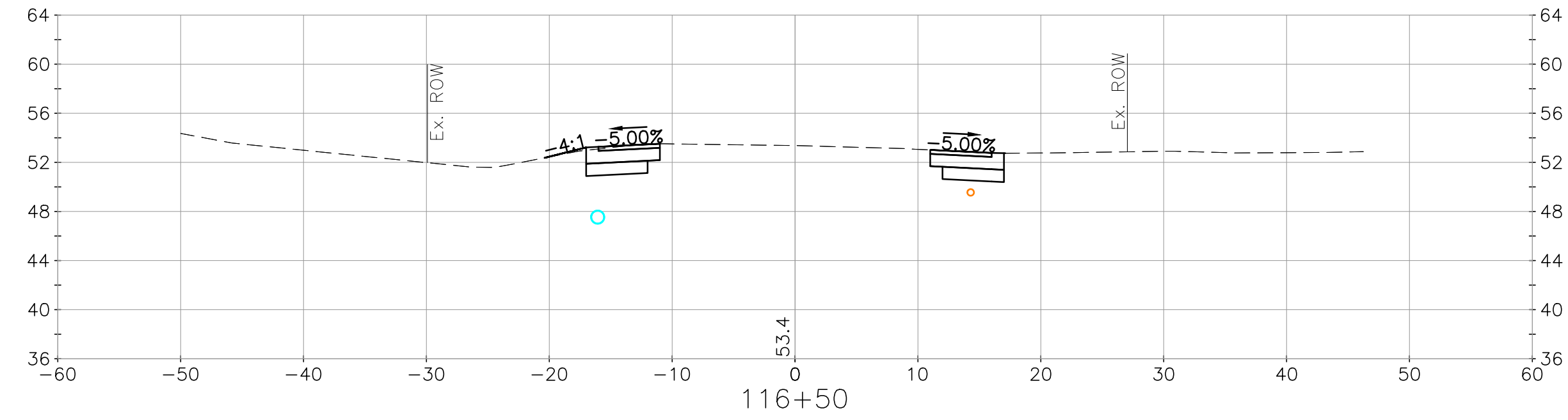
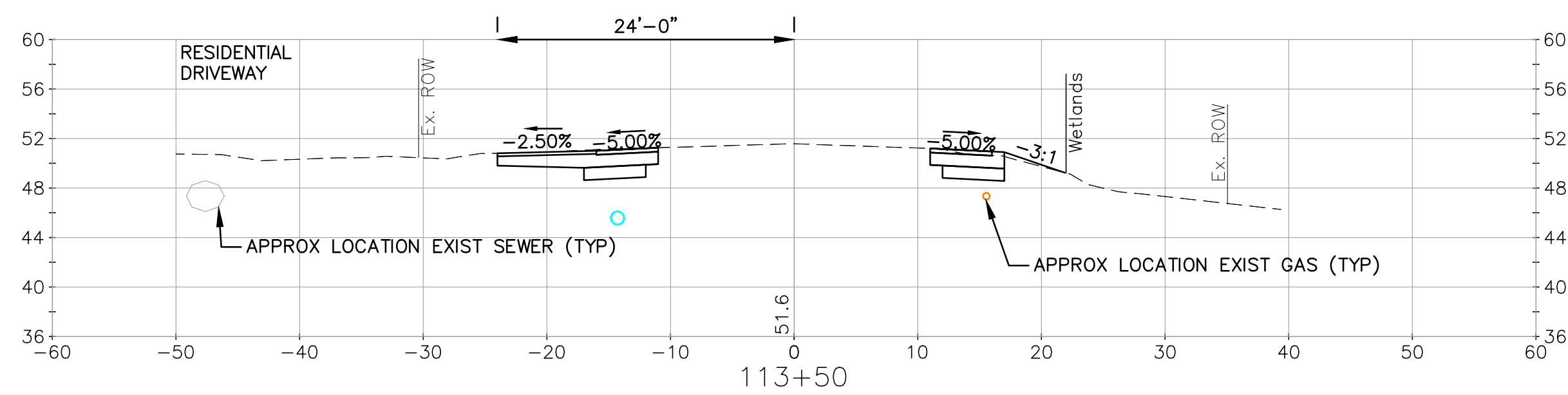
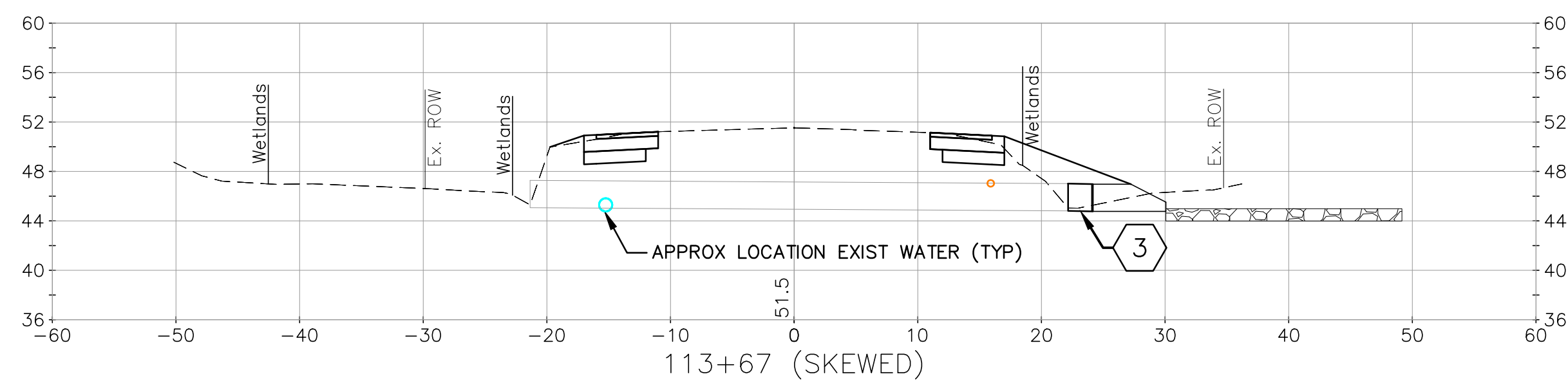
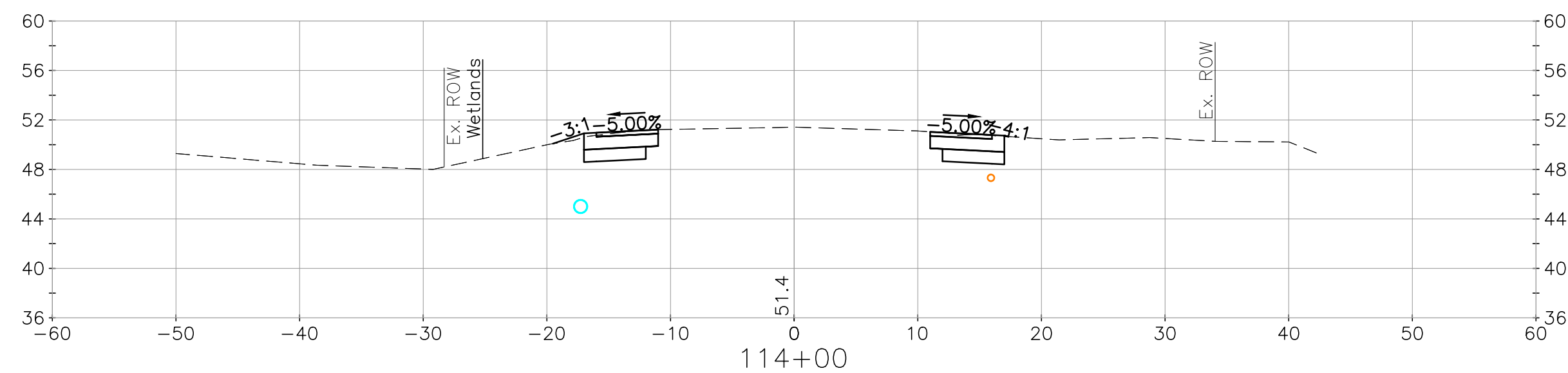
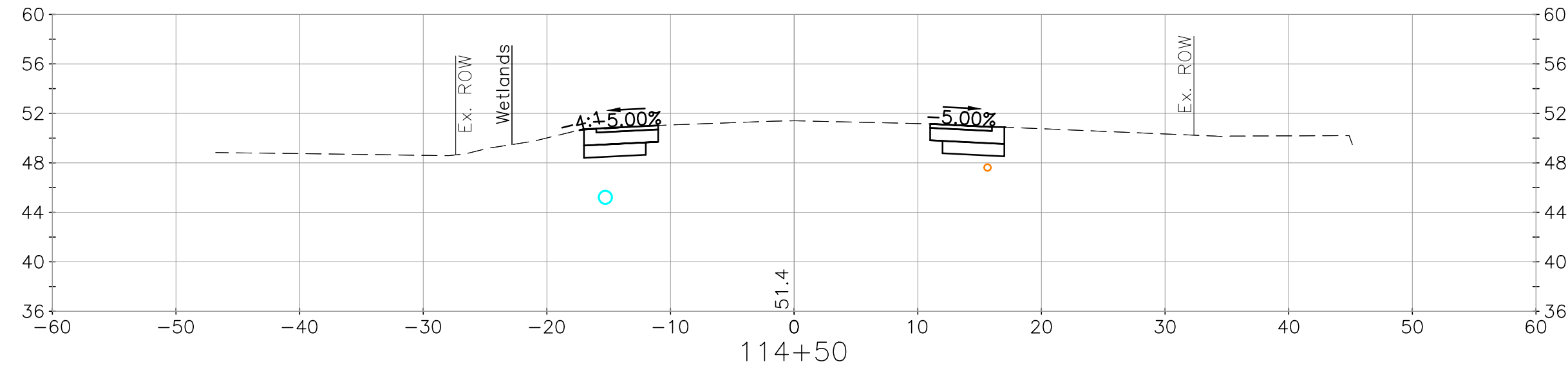

no.	1	Issued for Bidding	4/3/2023	JJB
revision			date	by

CMA ENGINEERS
 CIVIL/ENVIRONMENTAL/STRUCTURAL
 Portsmouth, NH • Manchester, NH • Portland, ME
 603/431-6196 • 603/627-0708 • 207/541-4223
 c m a e n g i n e e r s . c o m



date:	April 2023	designed by:	JJB/STF
project no.:	1030	drawn by:	ATP/STF
file name:	1030-Sections.dwg	approved by:	JJB

Scale: 1" = 10'
 Scale: 1" = 20'

Town of Exeter, New Hampshire
 Public Works Department
 Kingston Road TAP Project
 Exeter 40436, X-A004(406)
 Cross Sections
 STA 113+50 to STA 116+50

drawing no.
XS-6
 sheet: 29 of 42

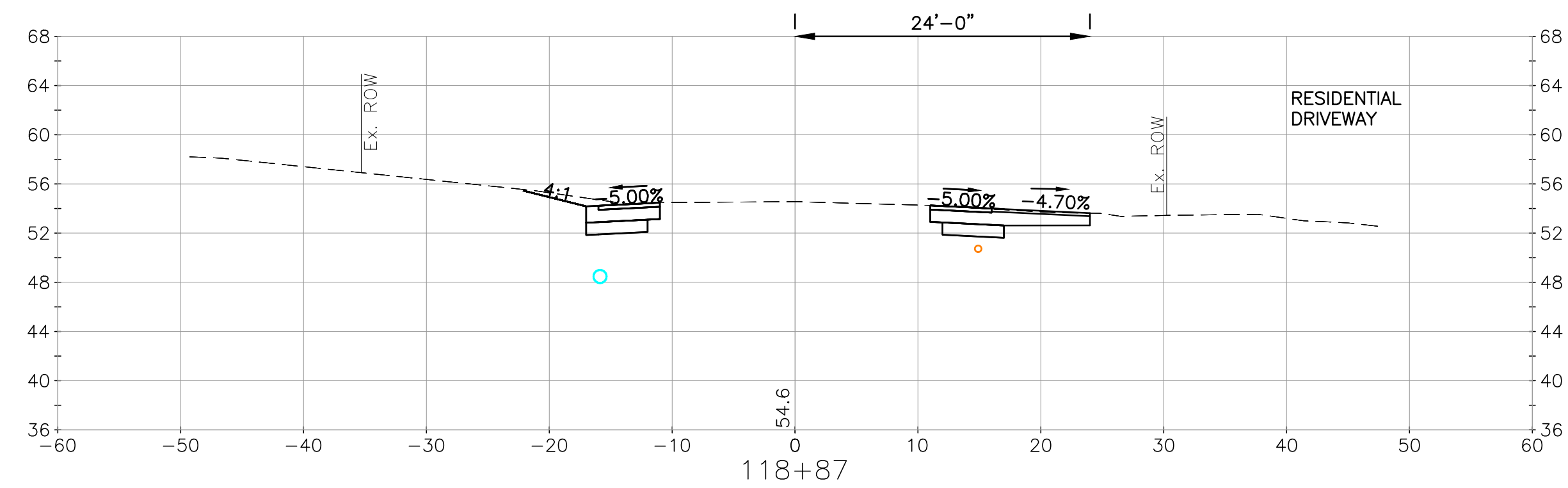
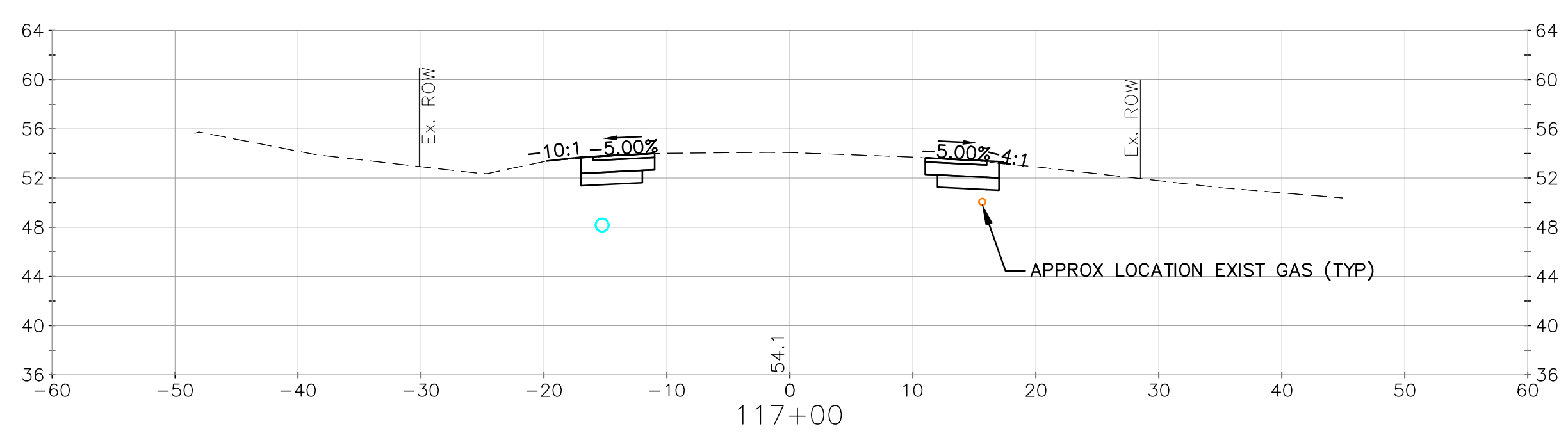
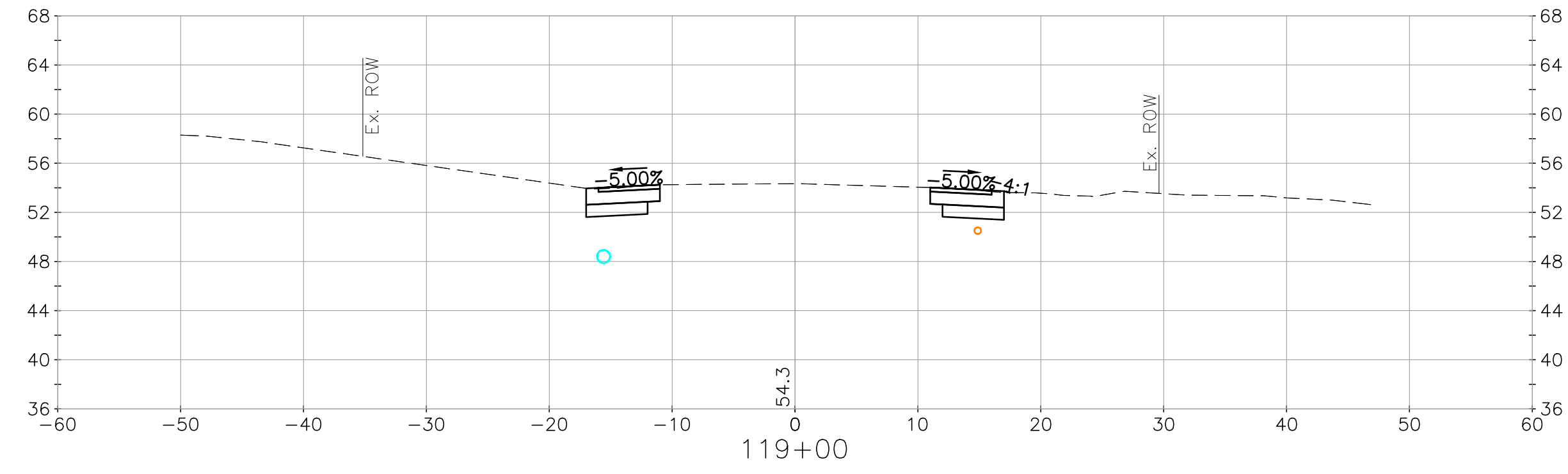
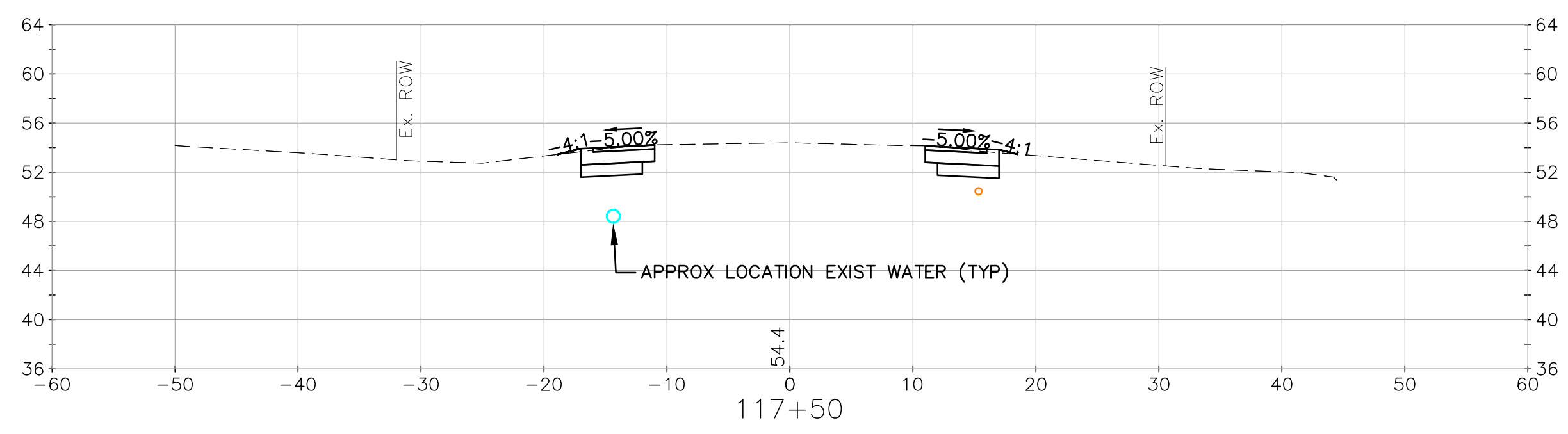
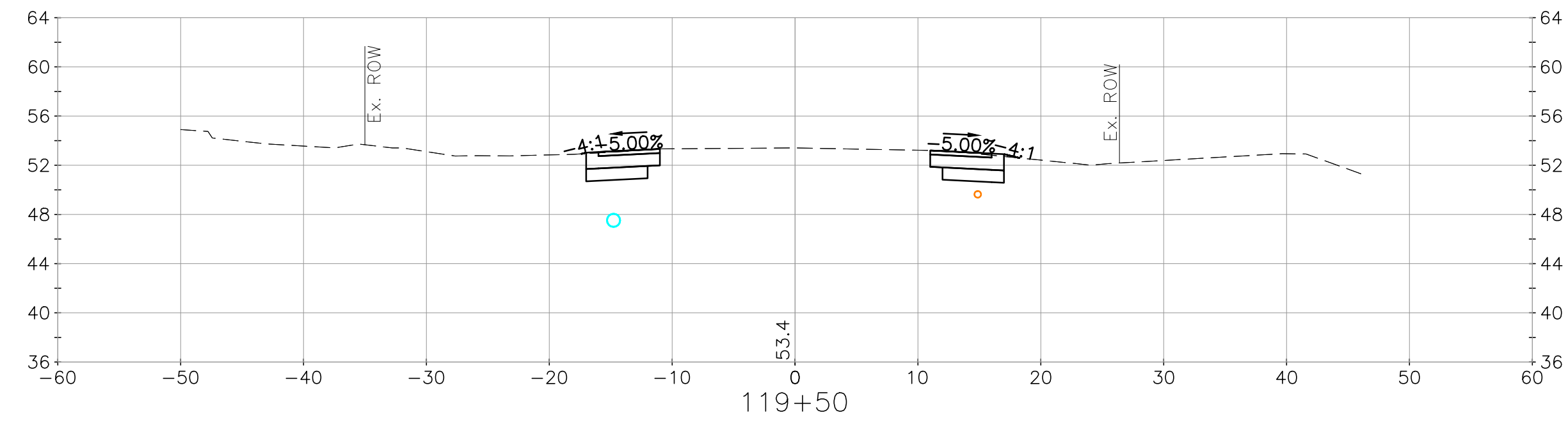
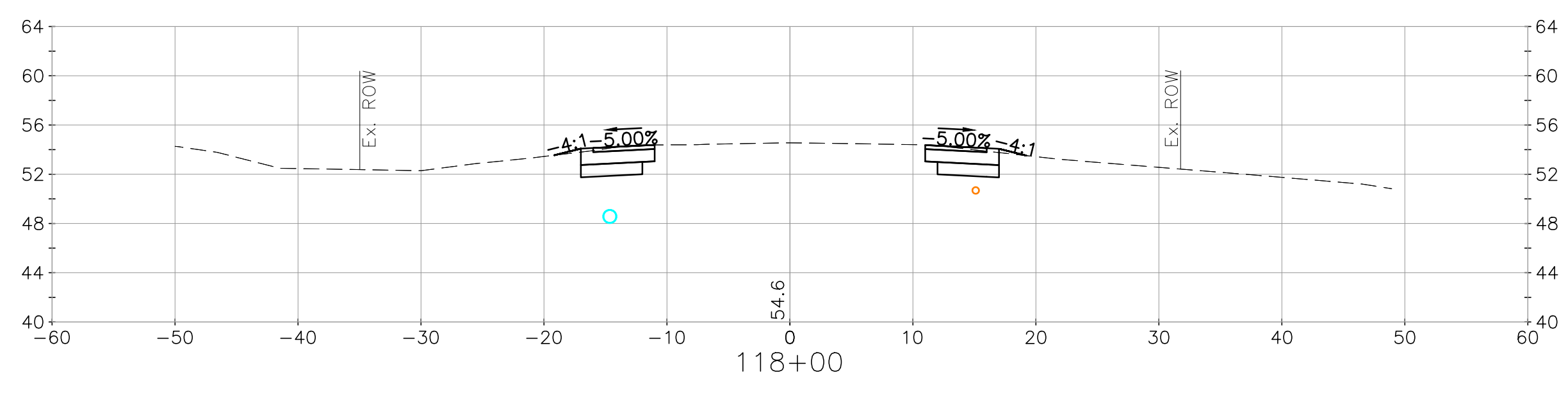
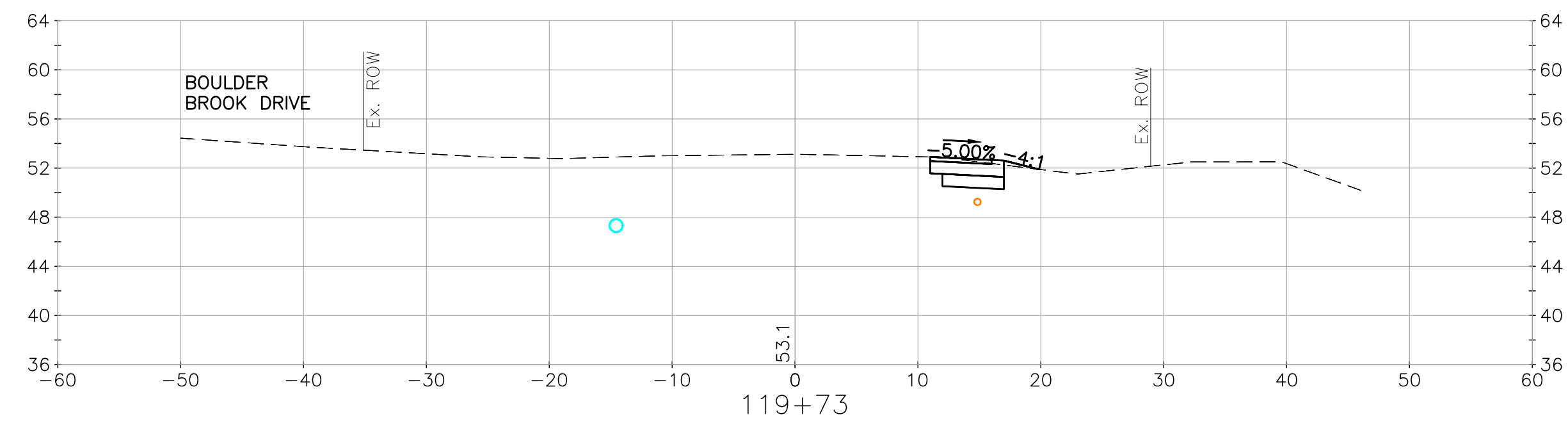
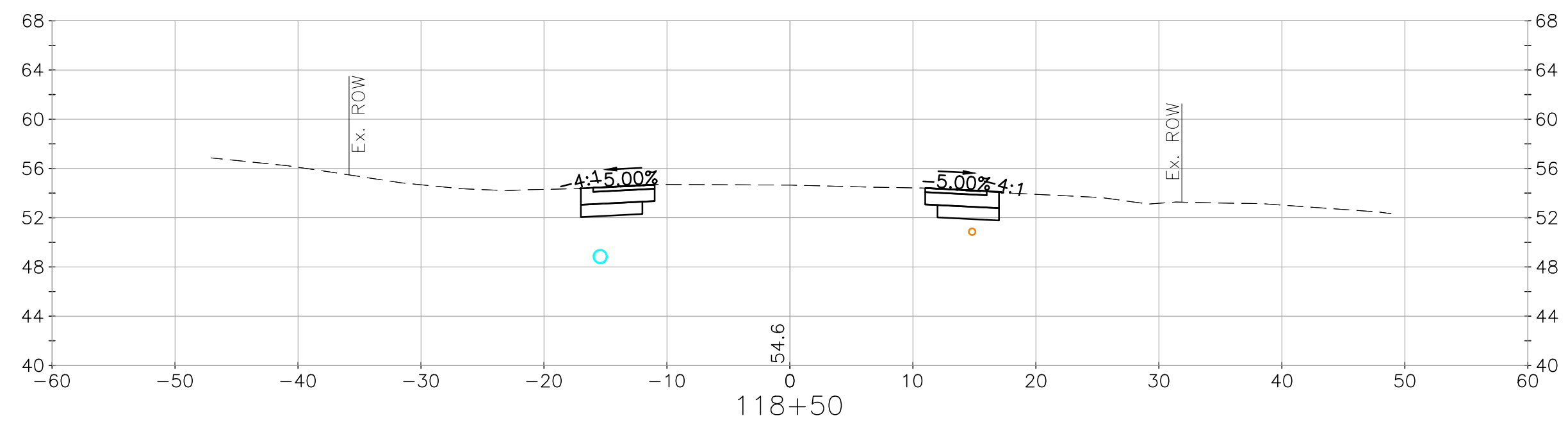

no.	1	Issued for Bidding	date	4/3/2023	JJB	by
revision						

CMA ENGINEERS
 CIVIL/ENVIRONMENTAL/STRUCTURAL
 Portsmouth, NH • Manchester, NH • Portland, ME
 603/431-6196 • 603/627-0708 • 207/541-4223
 c m a e n g i n e e r s . c o m

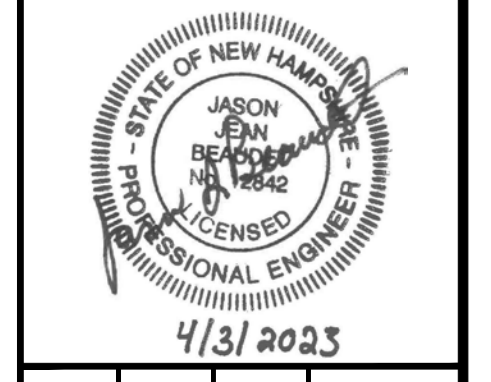

date:	April 2023	designed by:	JJB/STF
project no.:	1030	drawn by:	ATP/STF
file name:	1030-Sections.dwg	approved by:	JJB

Scale: 1" = 10'
 Scale: 1" = 20'

Town of Exeter, New Hampshire
 Public Works Department
 Kingston Road TAP Project
 Exeter 40436, X-A004(406)
 Cross Sections
 STA 117+00 to STA 119+73

drawing no.
XS-7
 sheet: 30 of 42

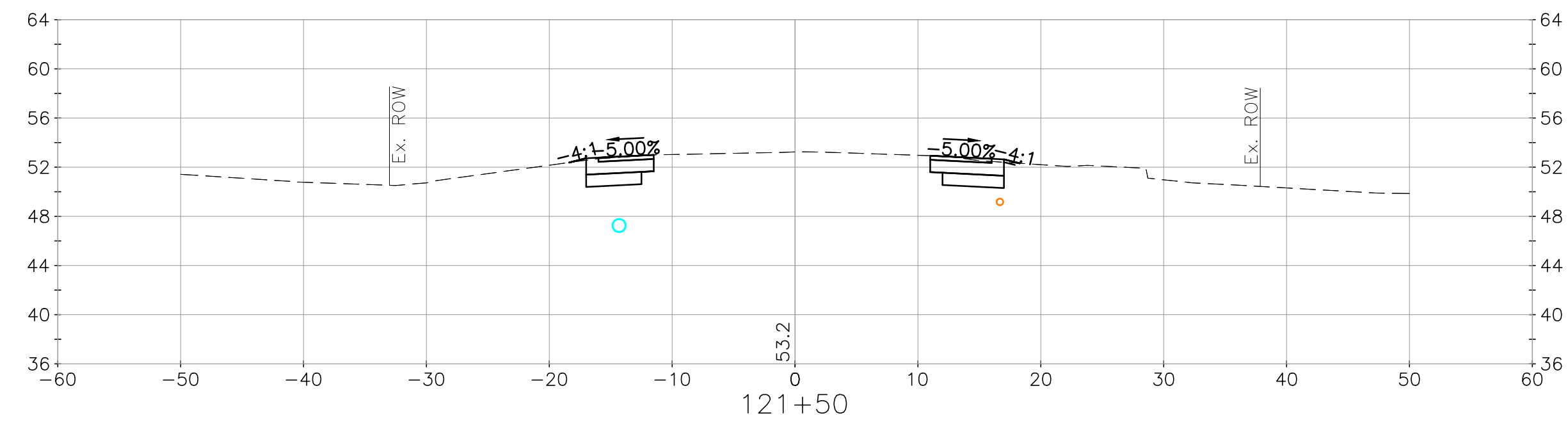
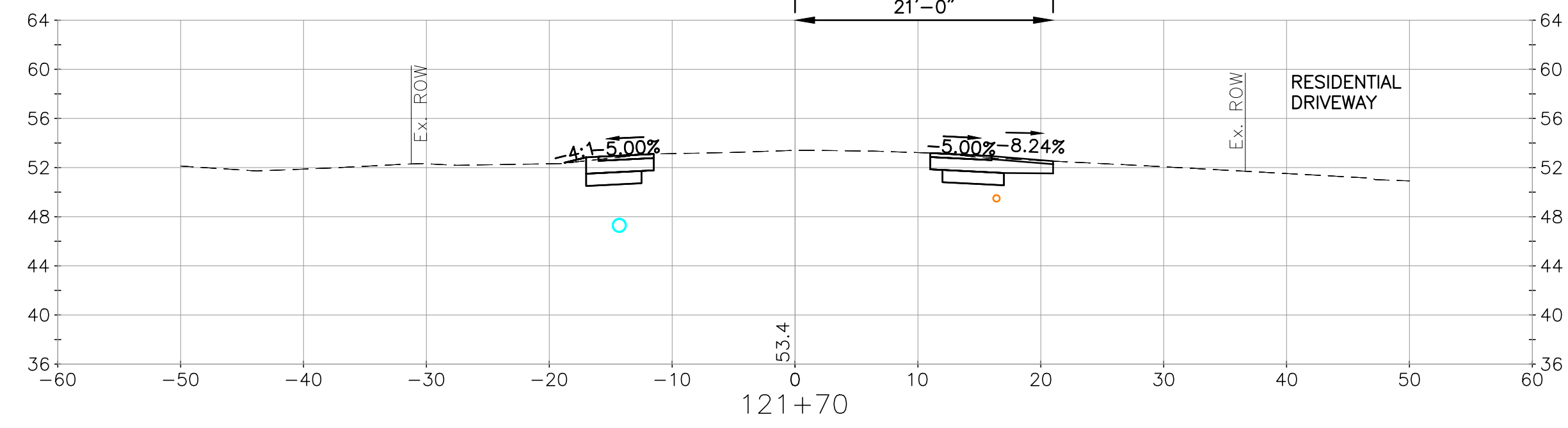
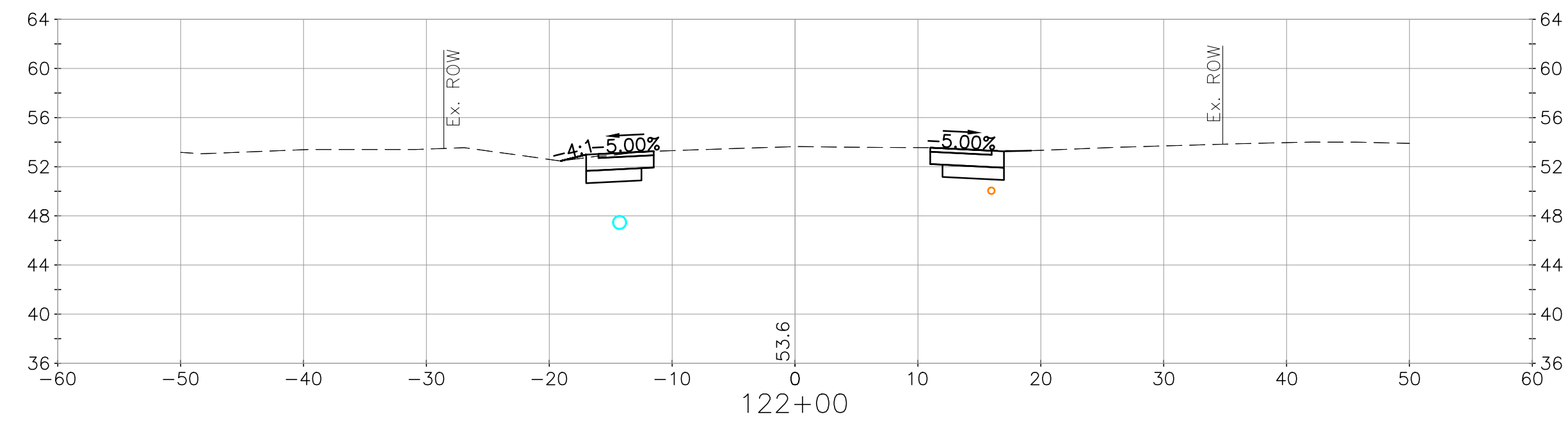
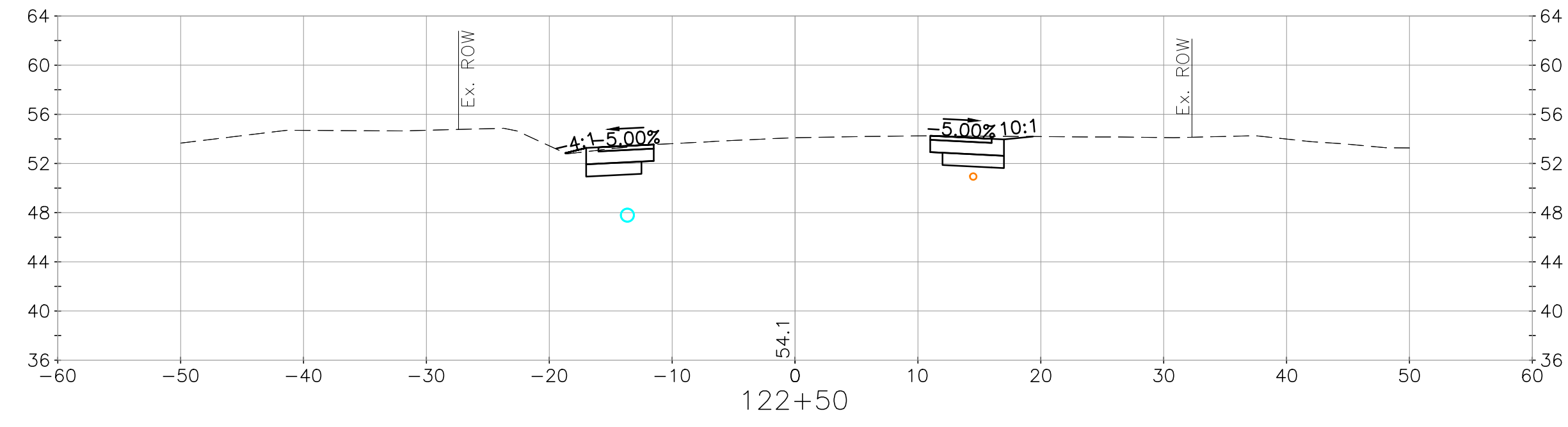
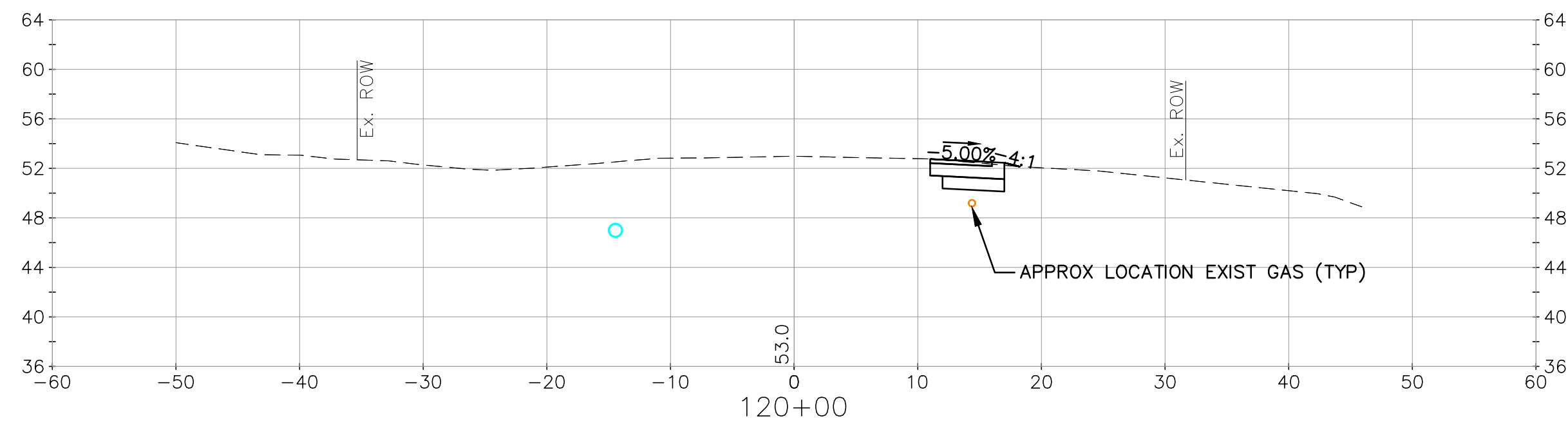
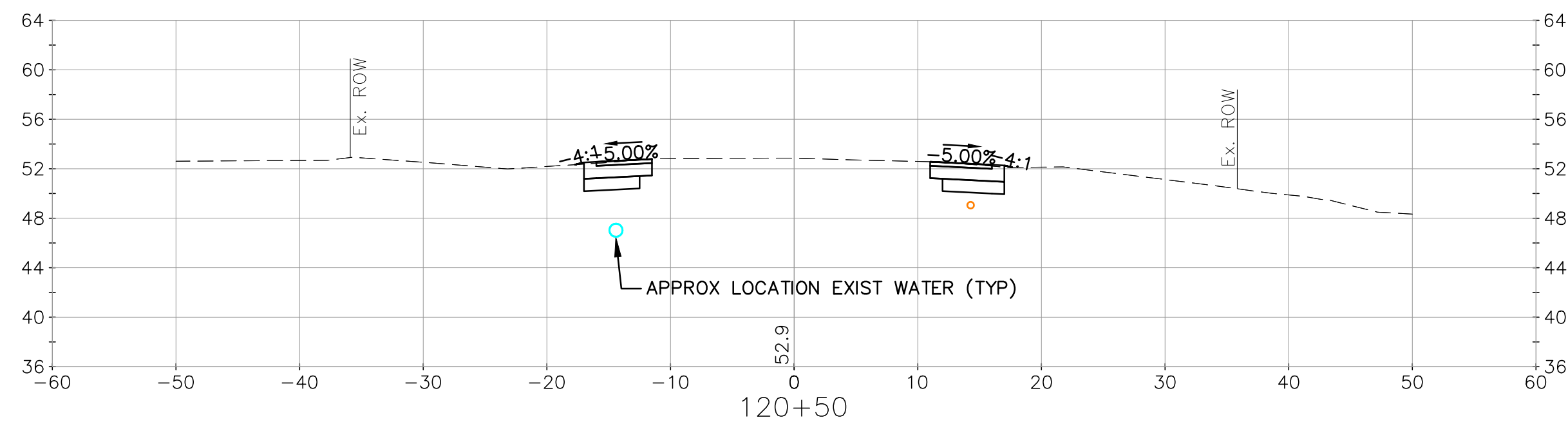
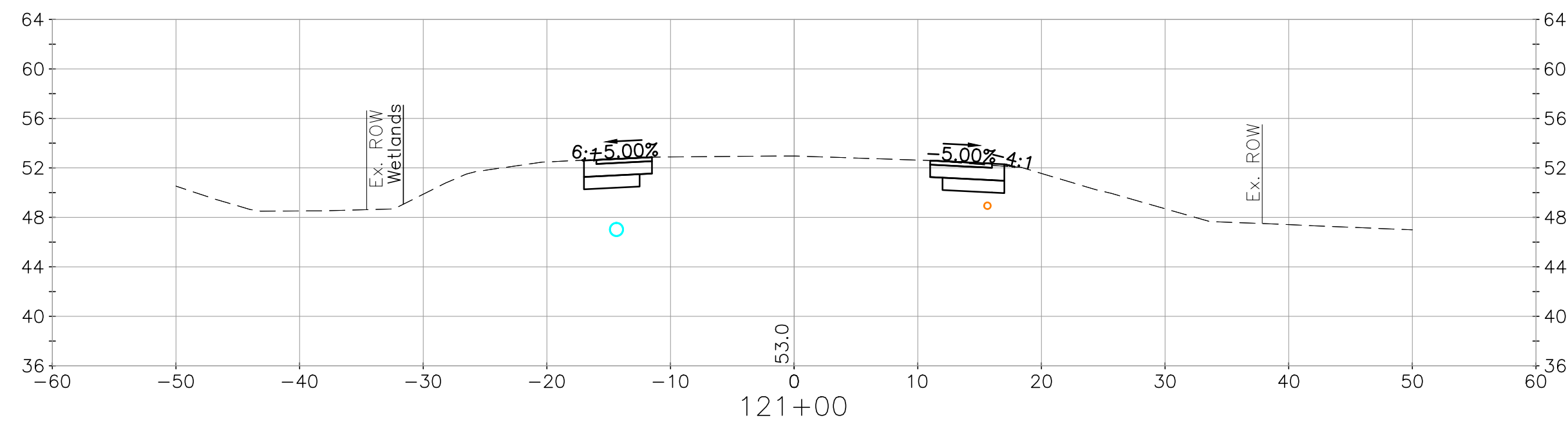
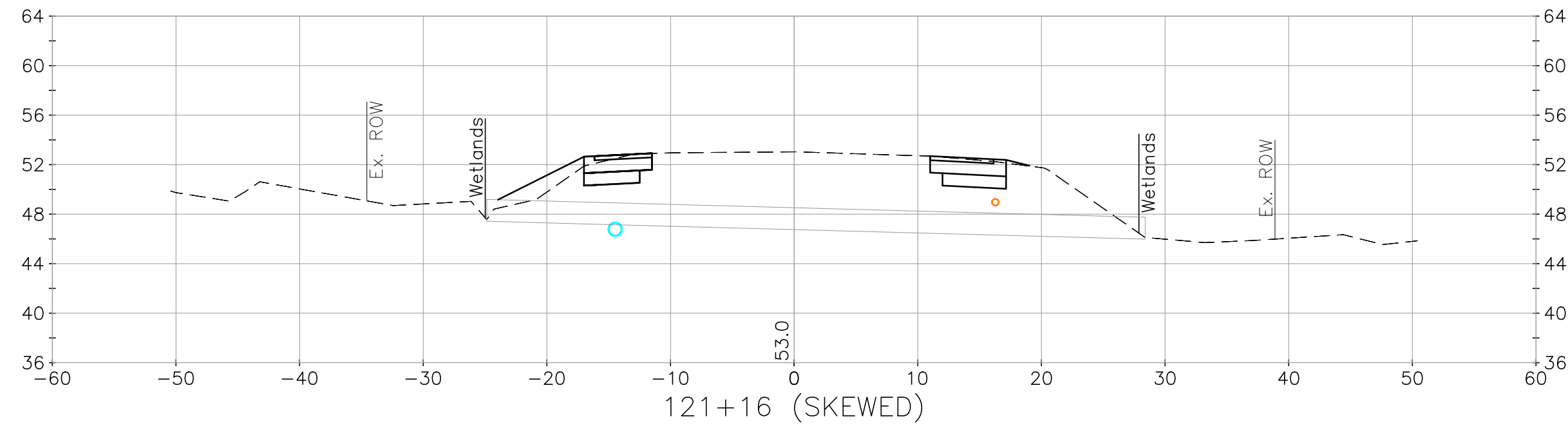

no.	1	Issued for Bidding	date	4/3/2023	JJB	by
revision						

CMA ENGINEERS
 CIVIL/ENVIRONMENTAL/STRUCTURAL
 Portsmouth, NH • Manchester, NH • Portland, ME
 603/431-6196 • 603/627-0708 • 207/541-4223
 c m a e n g i n e e r s . c o m

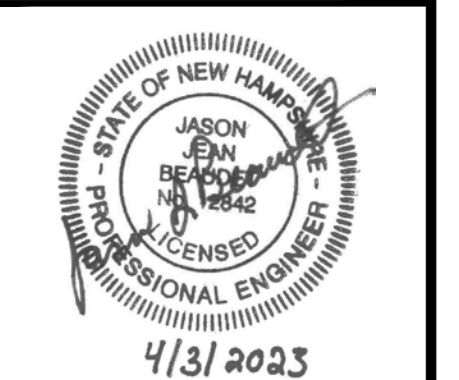

date:	April 2023	designed by:	JJB/STF
project no.:	1030	drawn by:	ATP/STF
file name:	1030-Sections.dwg	approved by:	JJB

Town of Exeter, New Hampshire
 Public Works Department
 Kingston Road TAP Project
 Exeter 40436, X-A004(406)
 Cross Sections
 STA 120+00 to STA 122+50

drawing no.	XS-8
sheet:	31 of 42

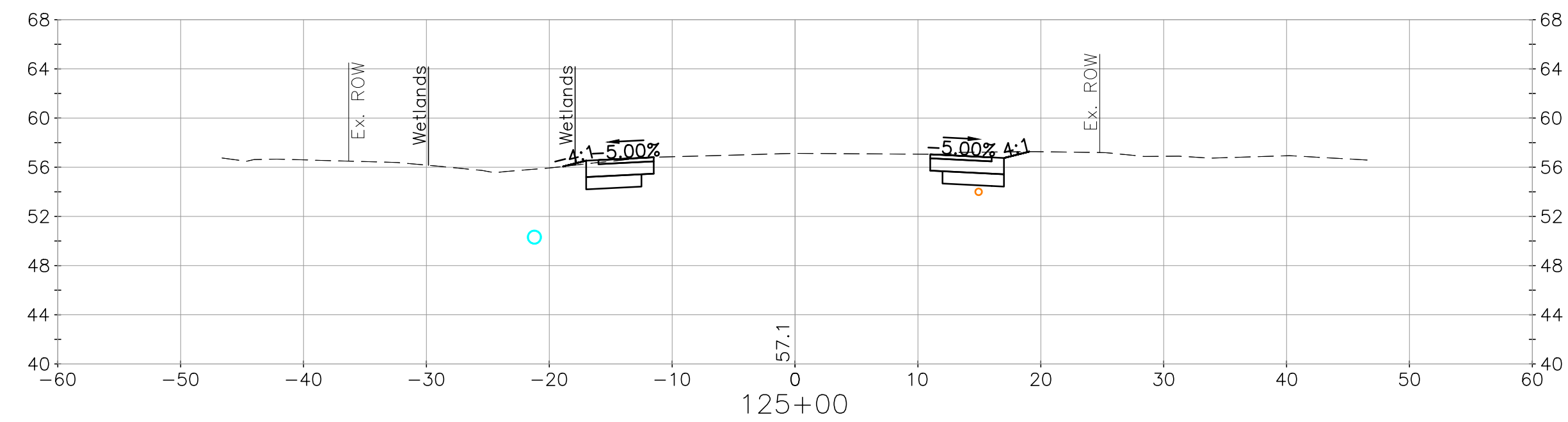
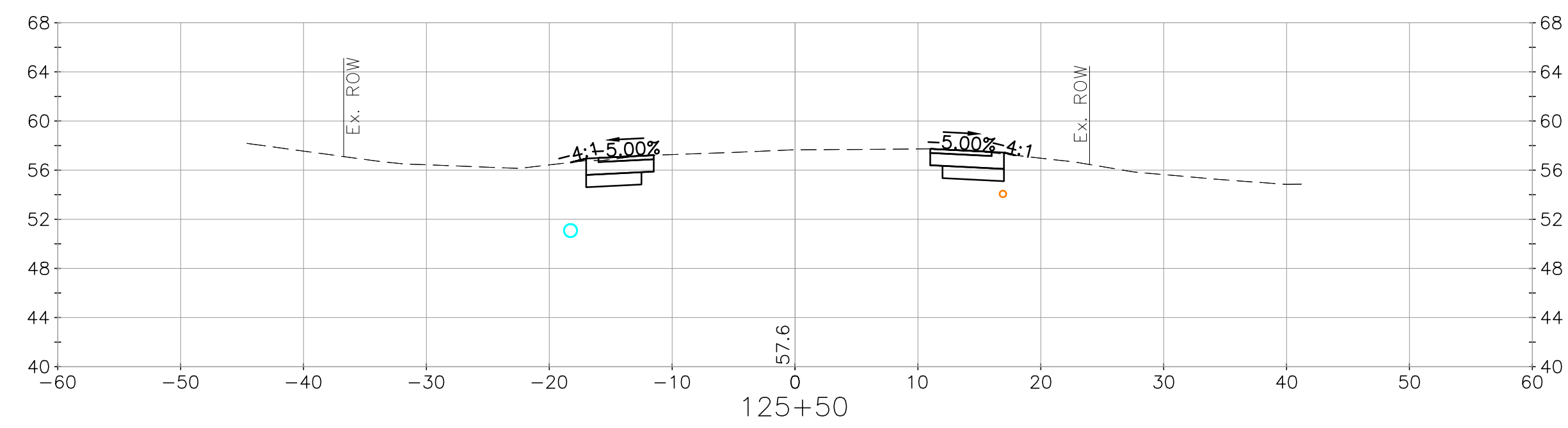
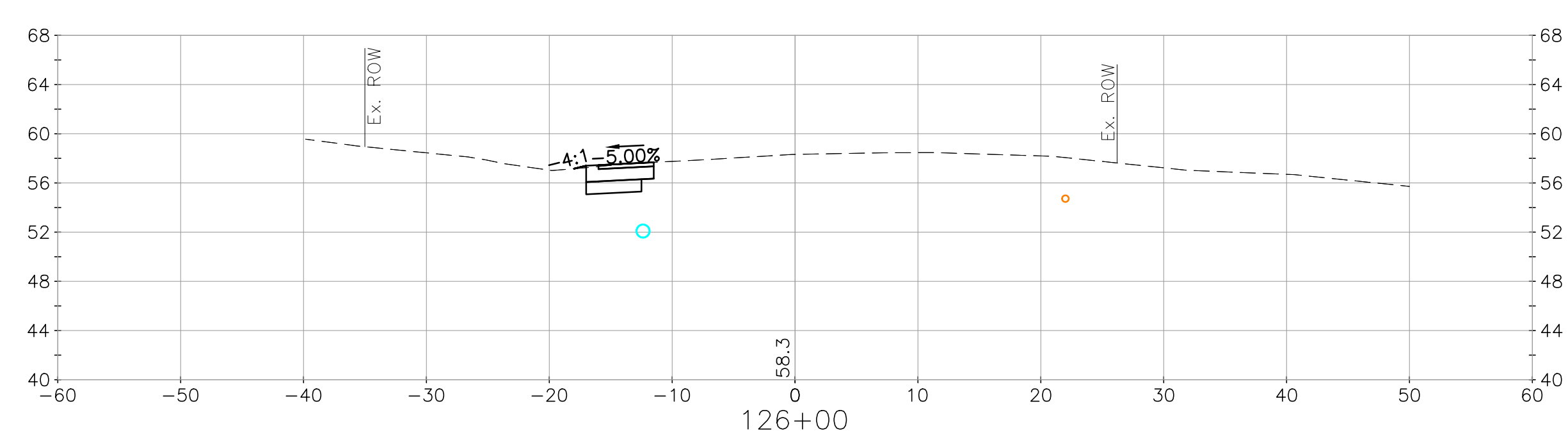
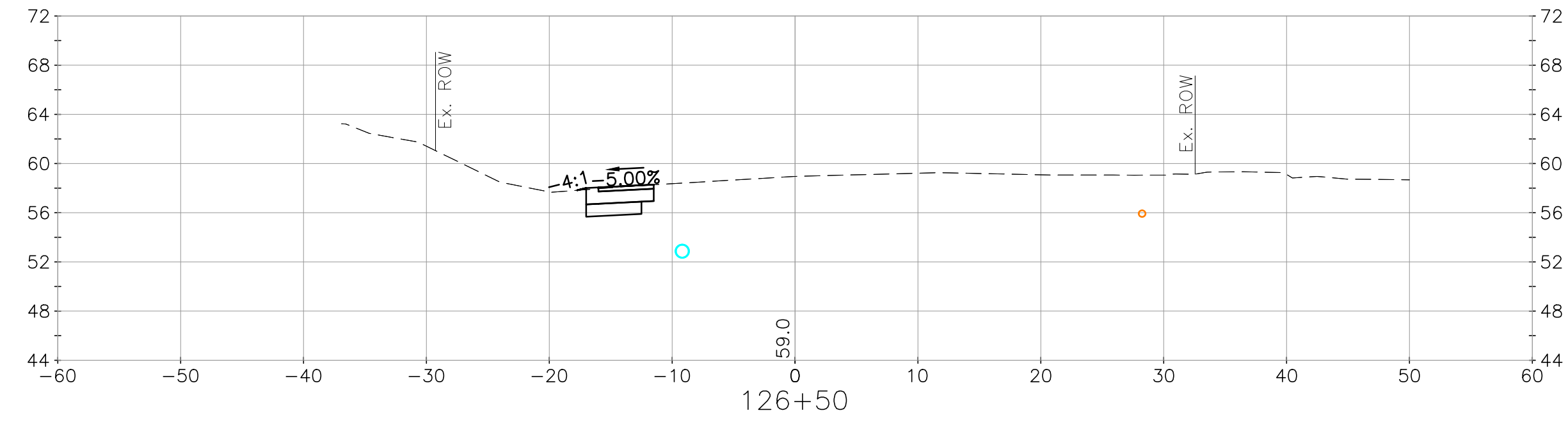
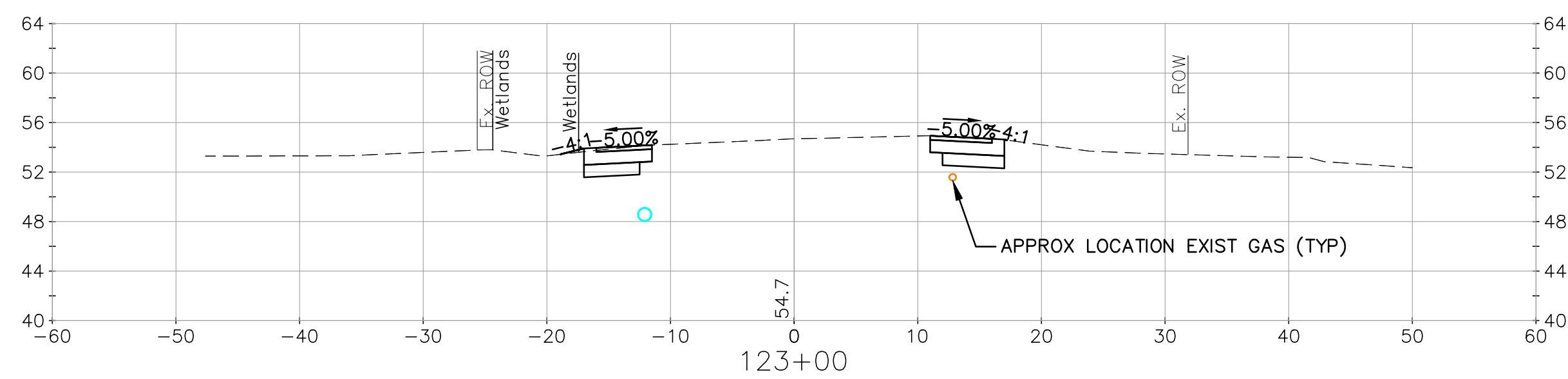
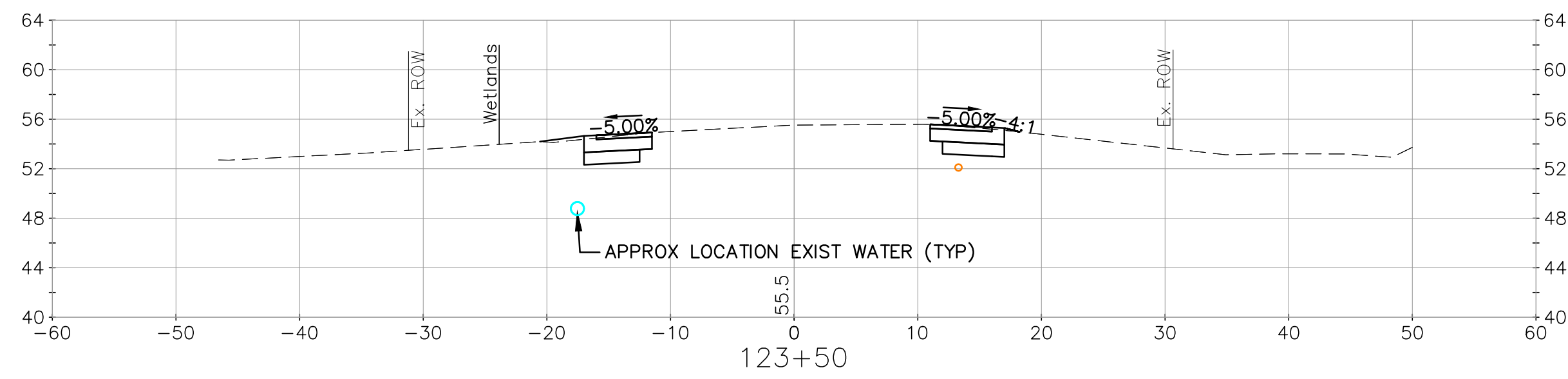
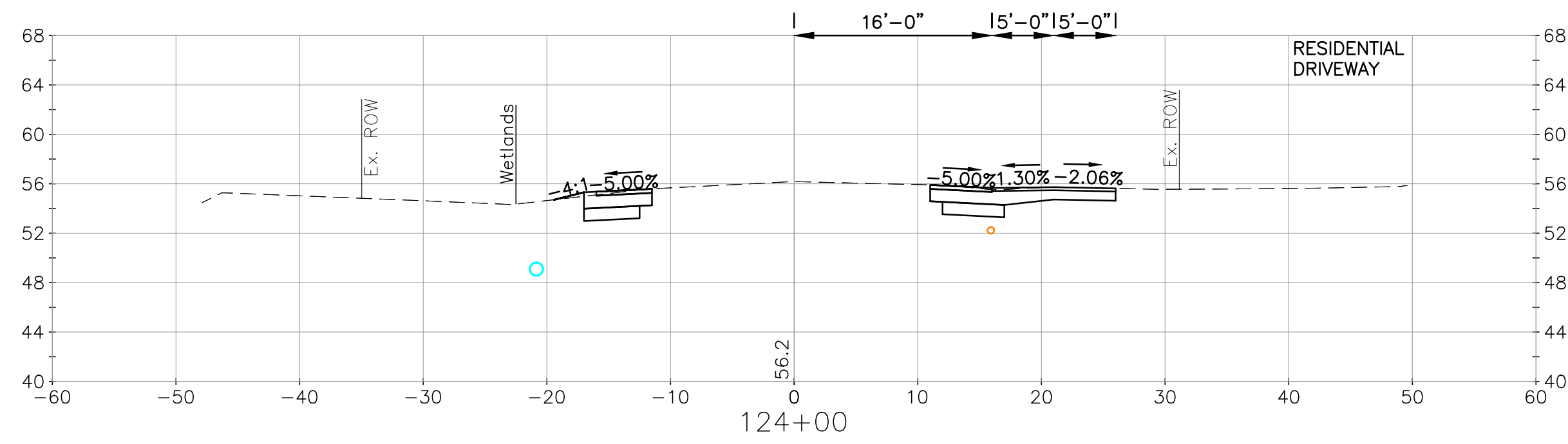
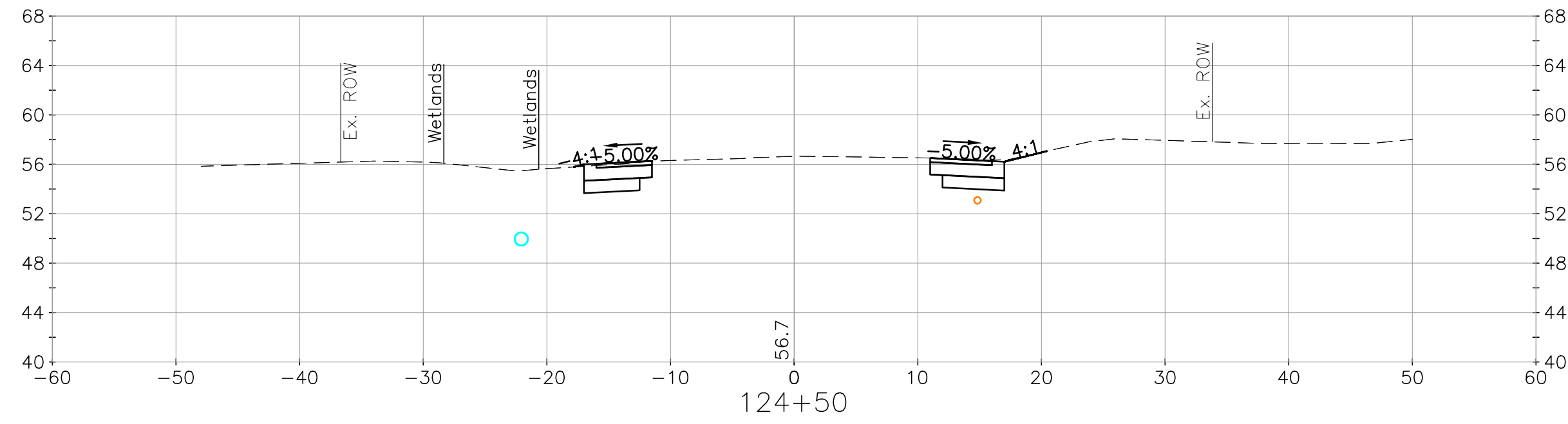

no.	1	Issued for Bidding	4/3/2023	JJB	by
revision					
date					

CMA ENGINEERS
 CIVIL/ENVIRONMENTAL/STRUCTURAL
 Portsmouth, NH • Manchester, NH • Portland, ME
 603/431-6196 • 603/627-0708 • 207/541-4223
 c m a e n g i n e e r s . c o m

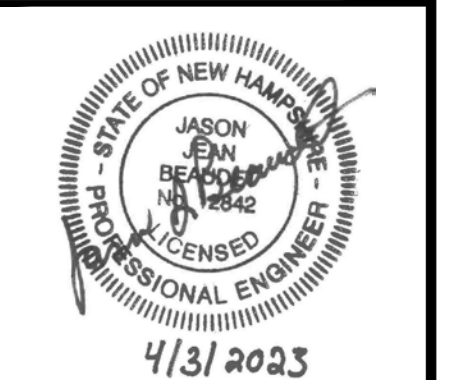



date:	April 2023	designed by:	JJB/STF
project no.:	1030	drawn by:	ATP/STF
file name:	1030-Sections.dwg	approved by:	JJB

Scale: 1" = 10'
 0 10' 20'

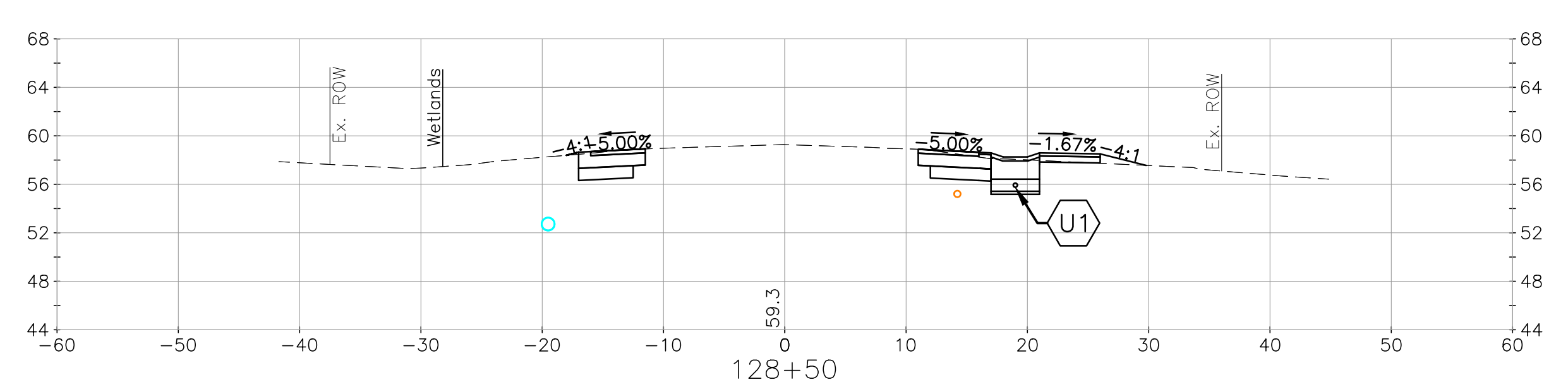
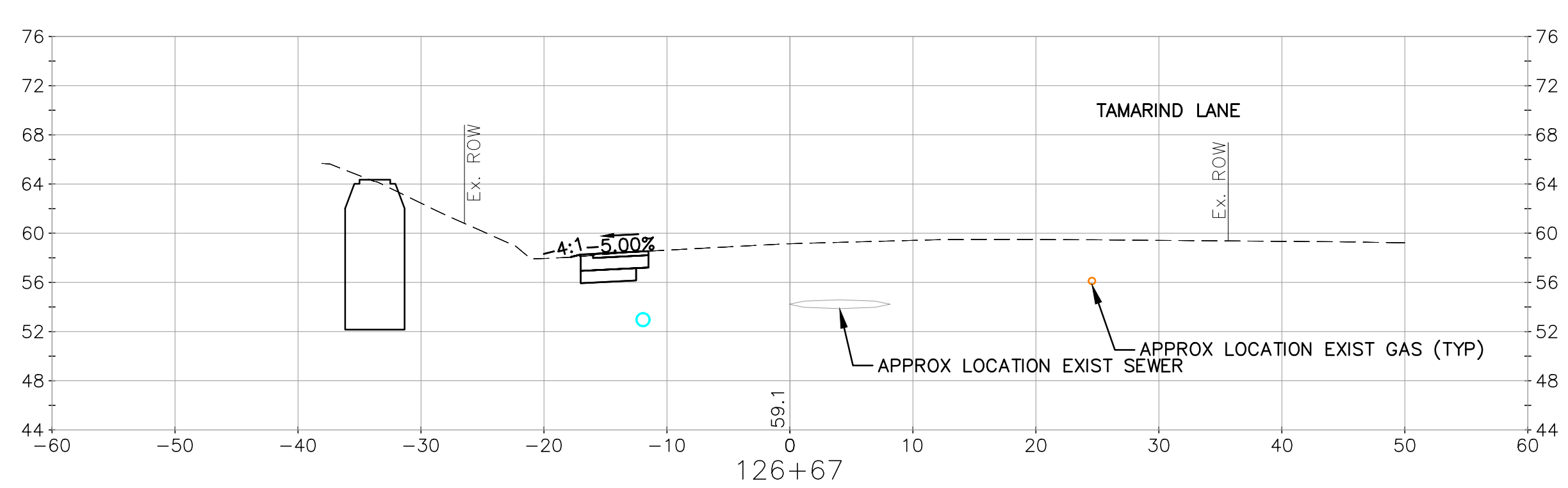
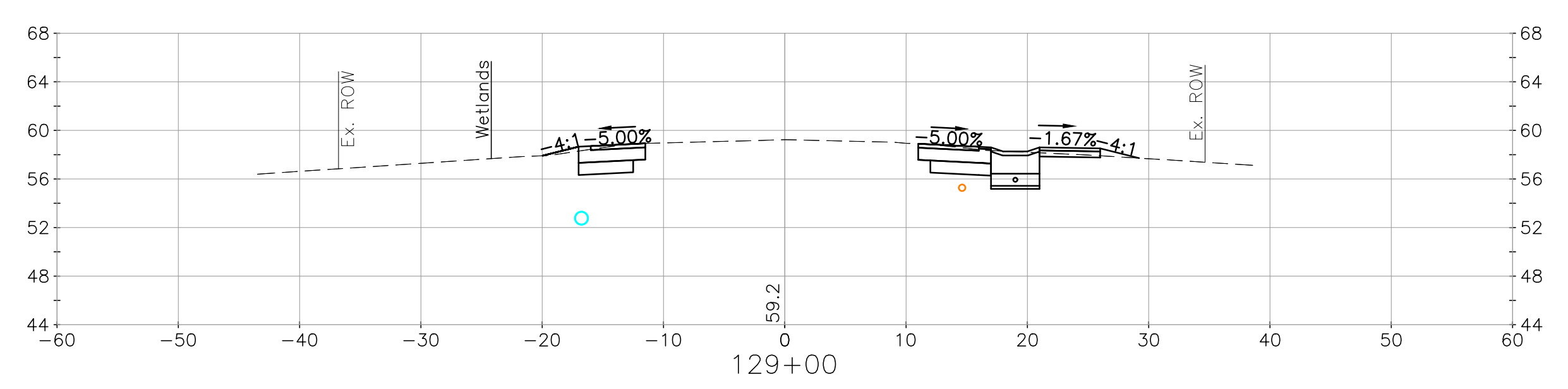
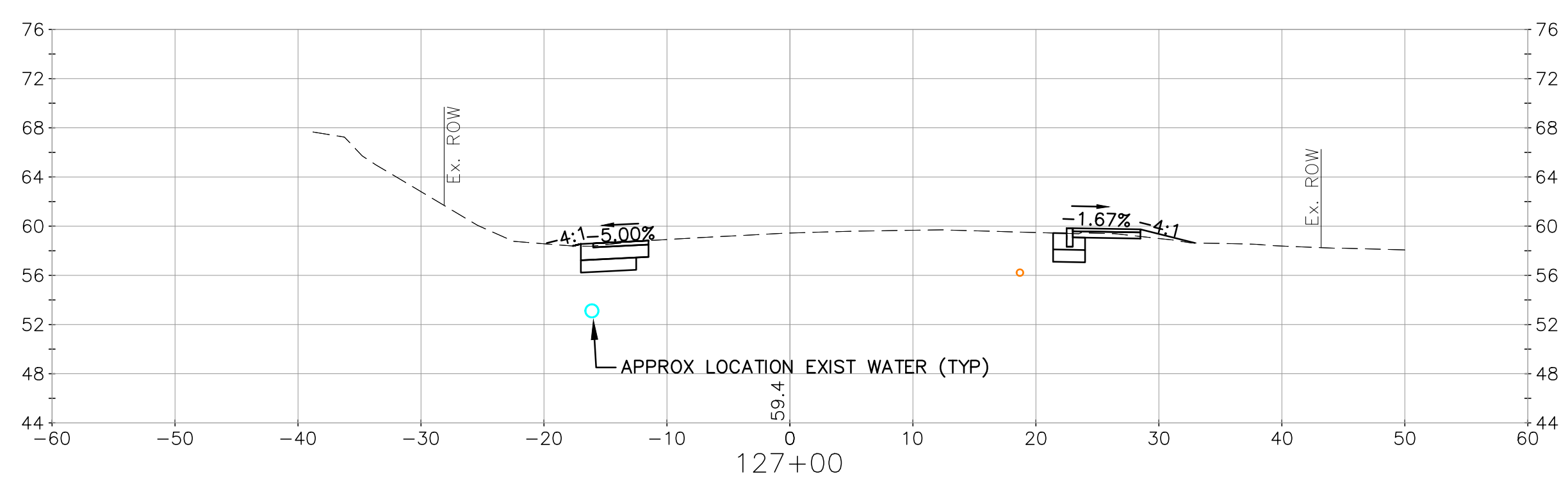
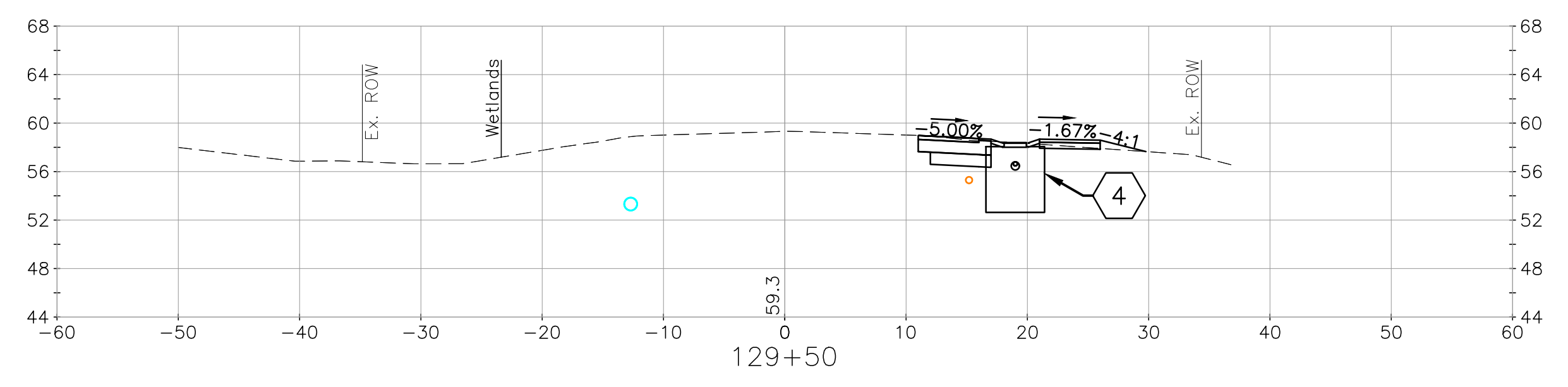
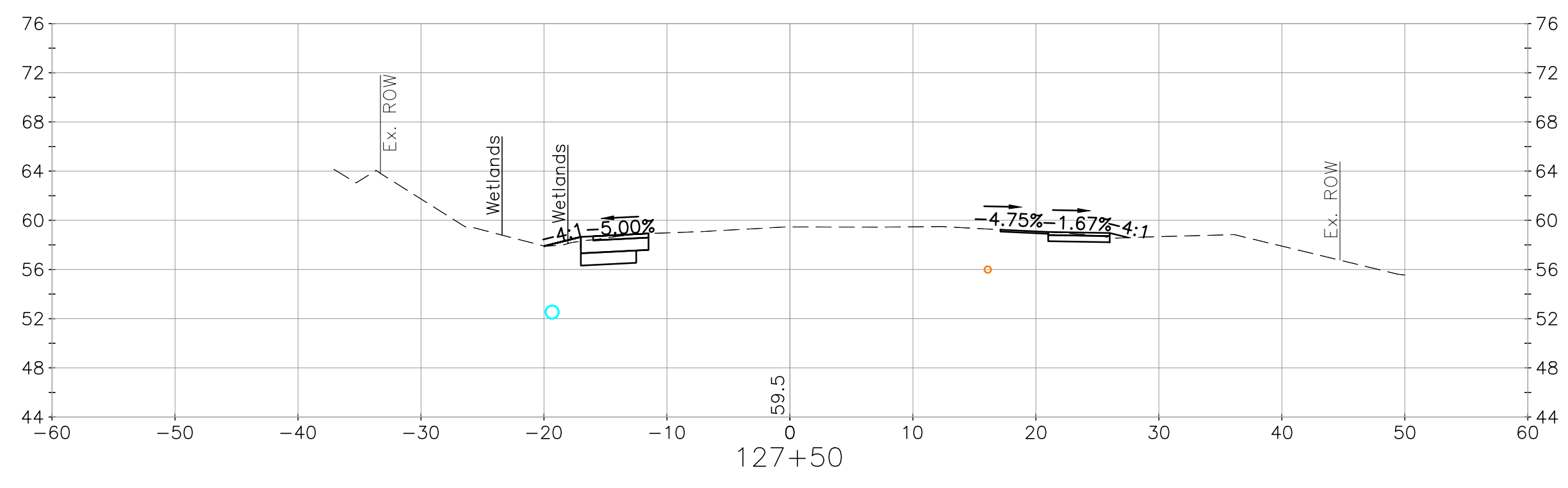
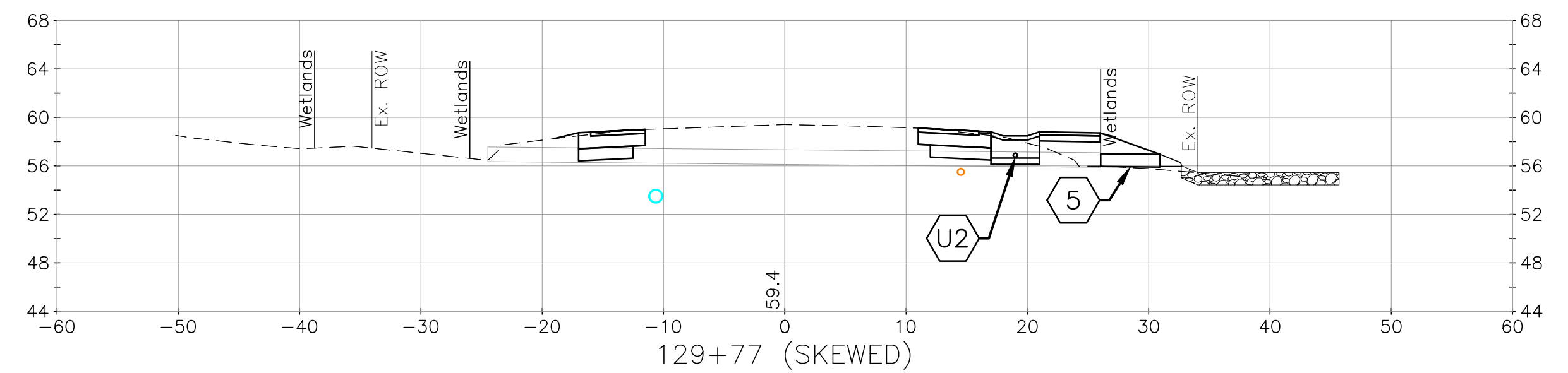
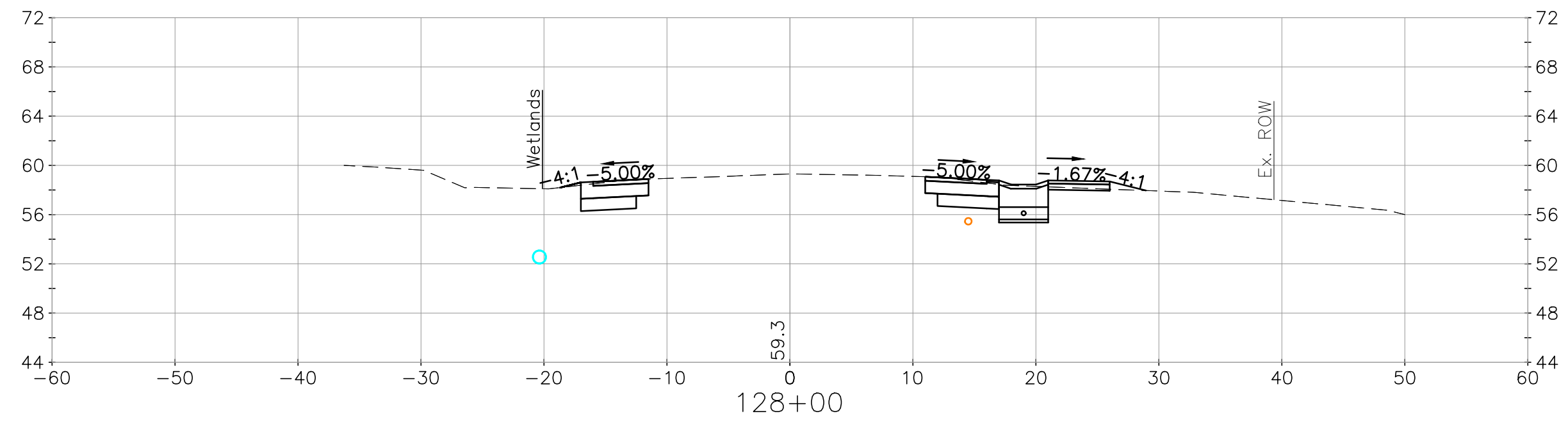
Town of Exeter, New Hampshire
 Public Works Department
 Kingston Road TAP Project
 Exeter 40436, X-A004(406)
 Cross Sections
 STA 123+00 to STA 126+50

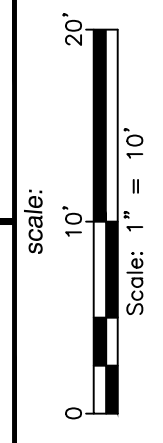

 CIVIL/ENVIRONMENTAL/STRUCTURAL Portsmouth, NH • Manchester, NH • Portland, ME 603/431-6196 • 603/627-0708 • 207/541-4223 c m a e n g i n e e r s . c o m		1 no.
 4/31/2023		4/3/2023 date
date: April 2023	designed by: JUB/STF	no. 1
project no: 1030	drawn by: ATR/STF	date 4/3/2023
file name: 1030-Sections.dwg	approved by: JUB	revision 1
		by JUB
Town of Exeter, New Hampshire Public Works Department Kingston Road TAP Project Exeter 40436, X-A004(406) Cross Sections STA 126+67 to STA 129+77		
drawing no. XS-10		
sheet: 33 of 42		

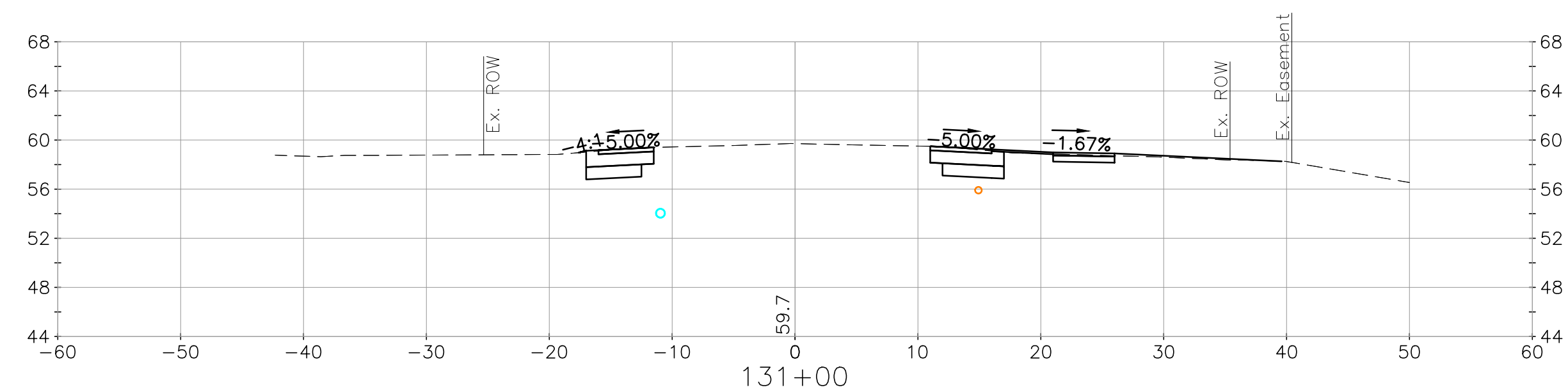
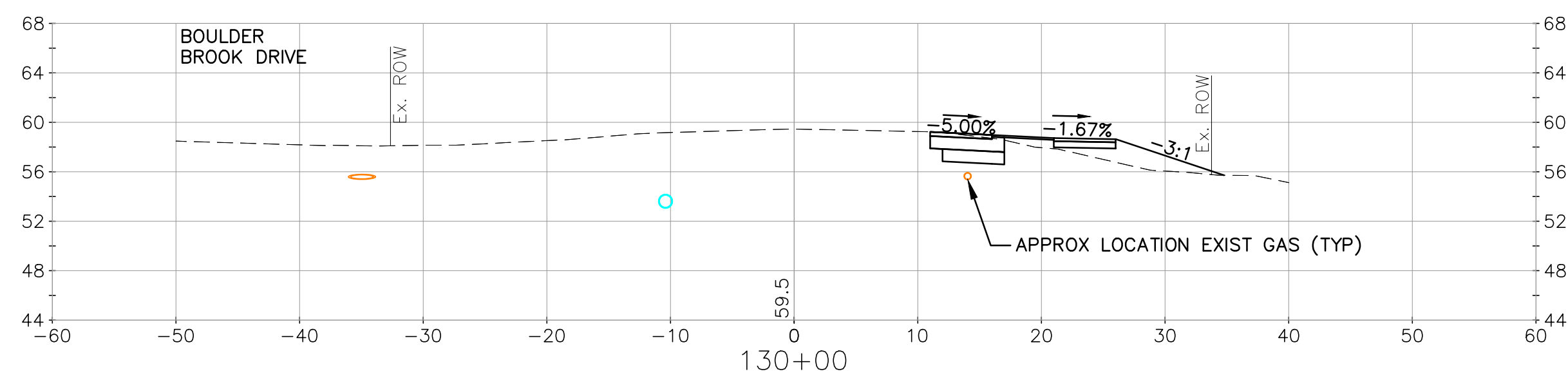
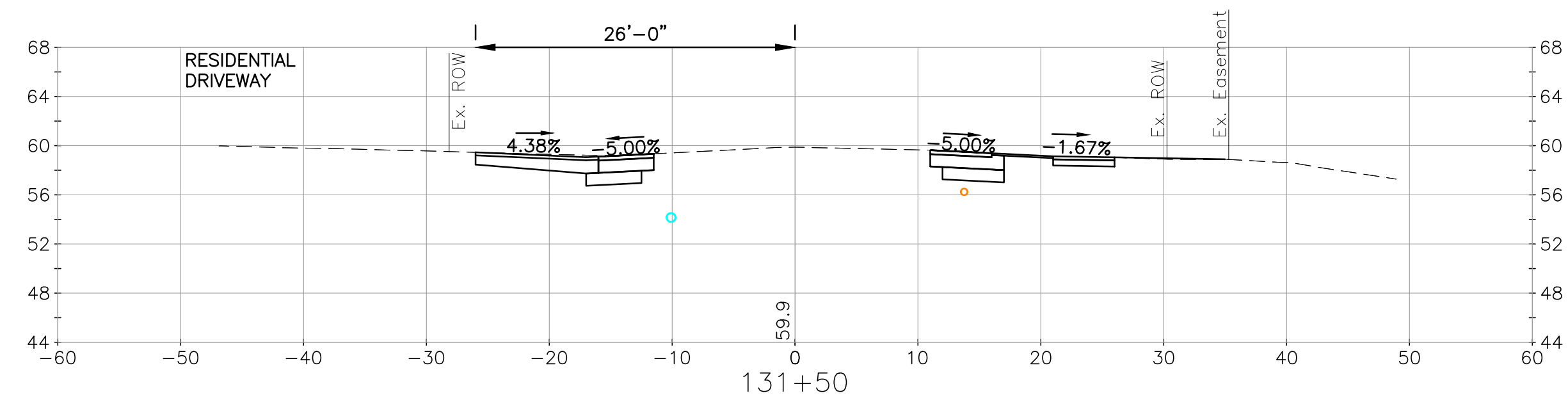
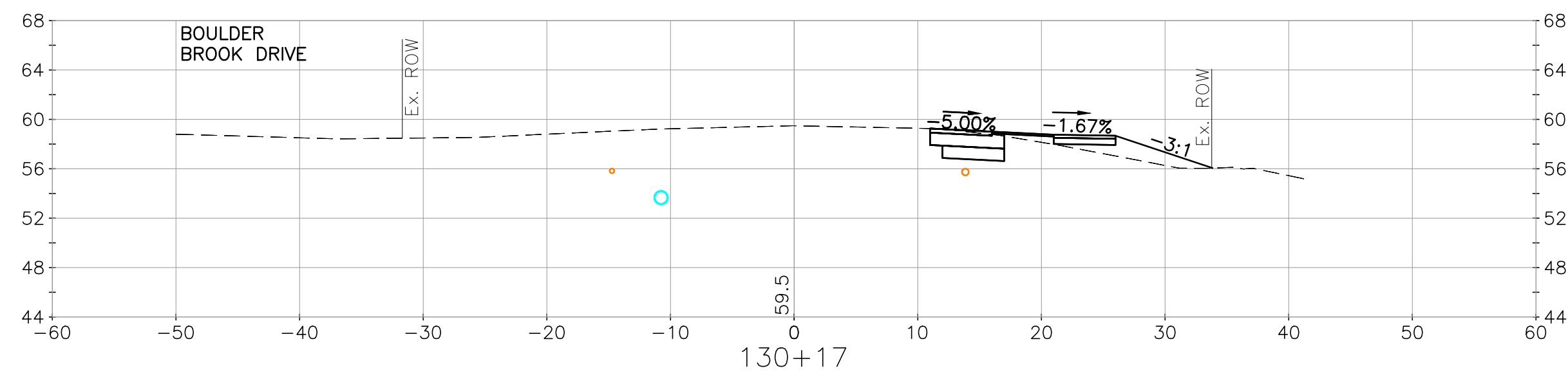
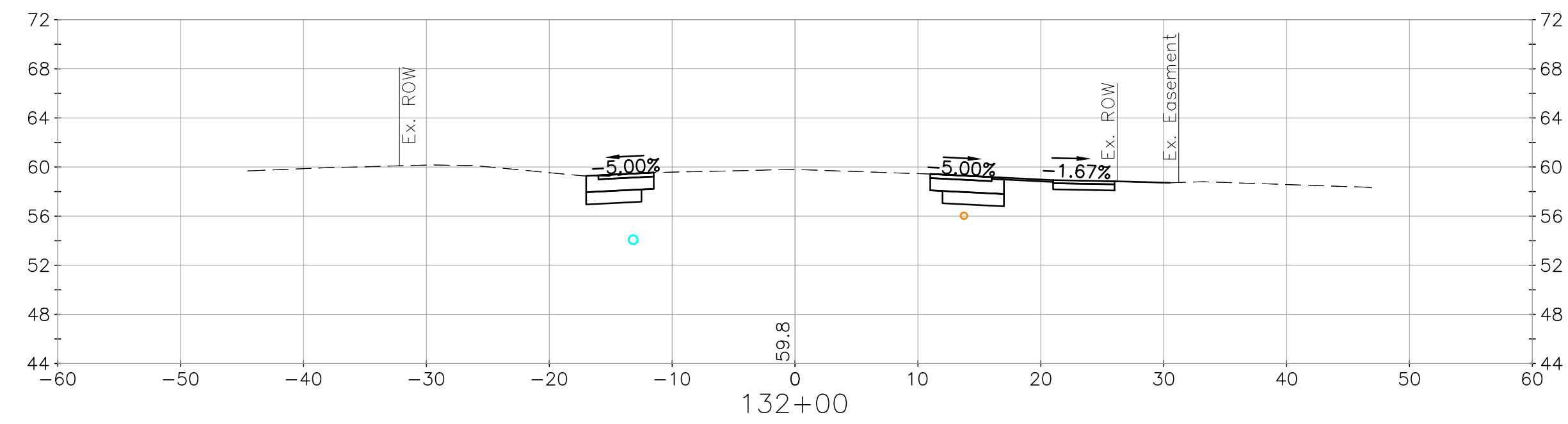
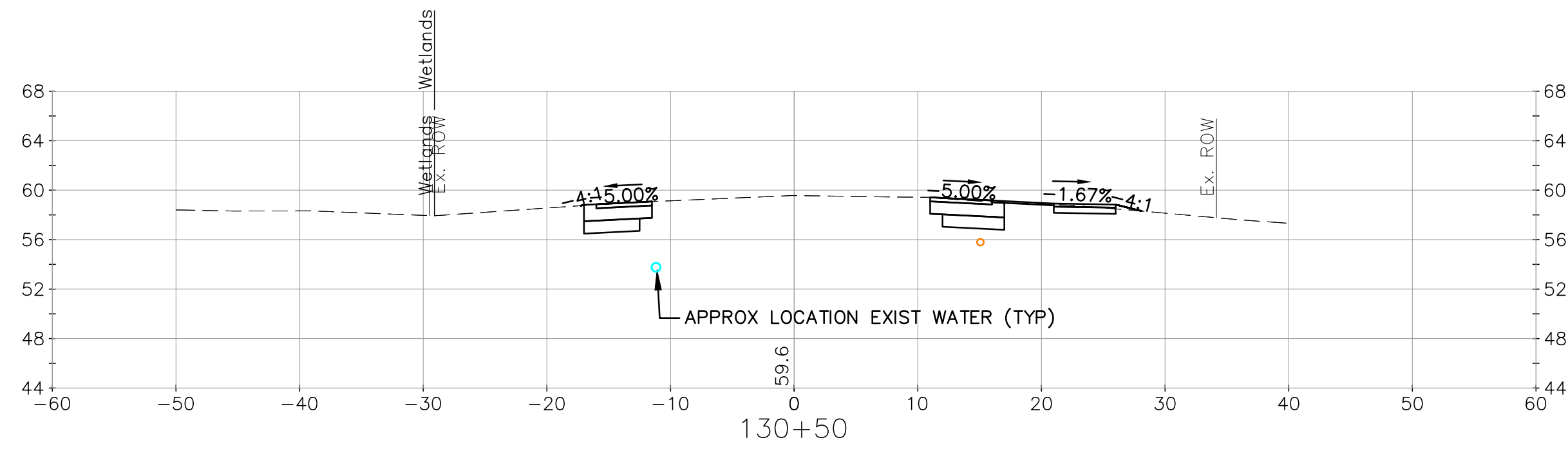
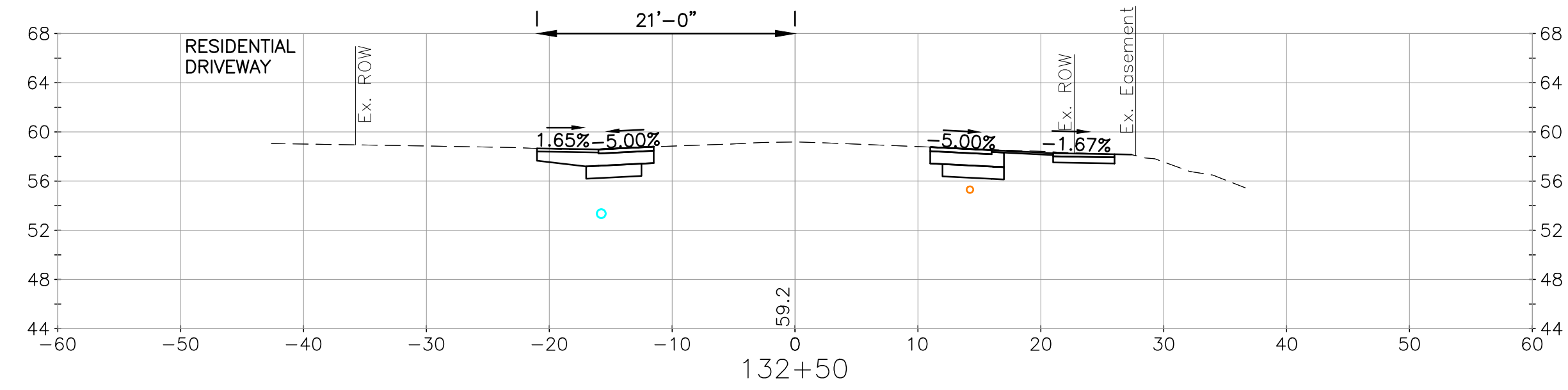
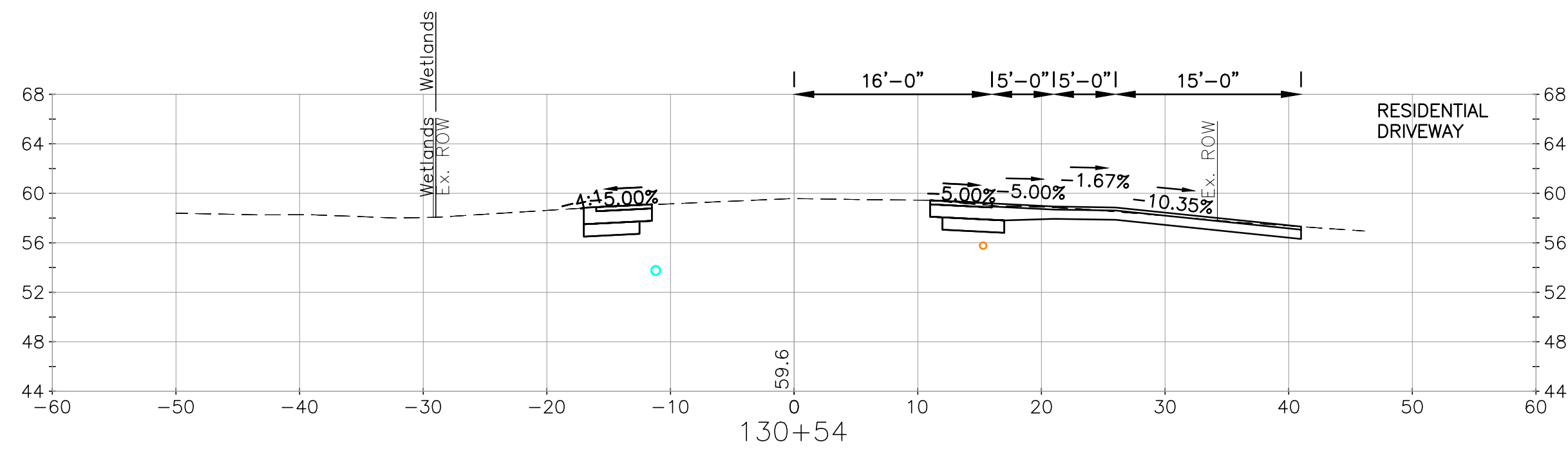

revision	no.	date	by
1	1	4/3/2023	JJB

CMA ENGINEERS
 CIVIL/ENVIRONMENTAL/STRUCTURAL
 Portsmouth, NH • Manchester, NH • Portland, ME
 603/431-6196 • 603/627-0708 • 207/541-4223
 c m a e n g i n e e r s . c o m

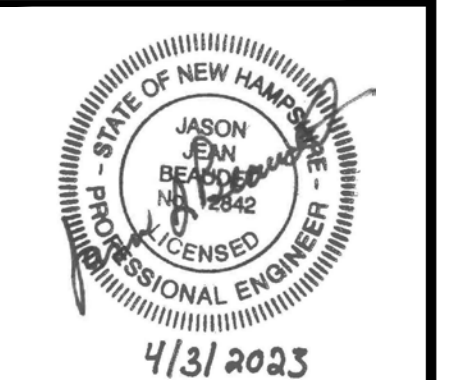

date:	April 2023	designed by:	JJB/STF
project no.:	1030	drawn by:	ATP/STF
file name:	1030-Sections.dwg	approved by:	JJB

Scale: 1" = 10'
 0 10' 20'

Town of Exeter, New Hampshire
 Public Works Department
 Kingston Road TAP Project
 Exeter 40436, X-A004(406)
 Cross Sections
 STA 130+00 to STA 132+50

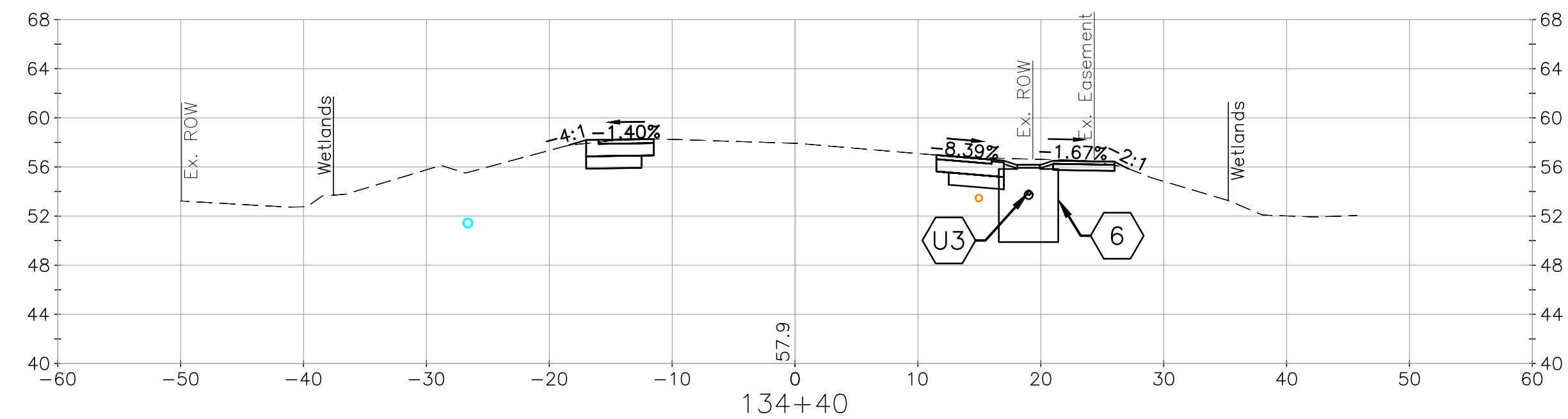
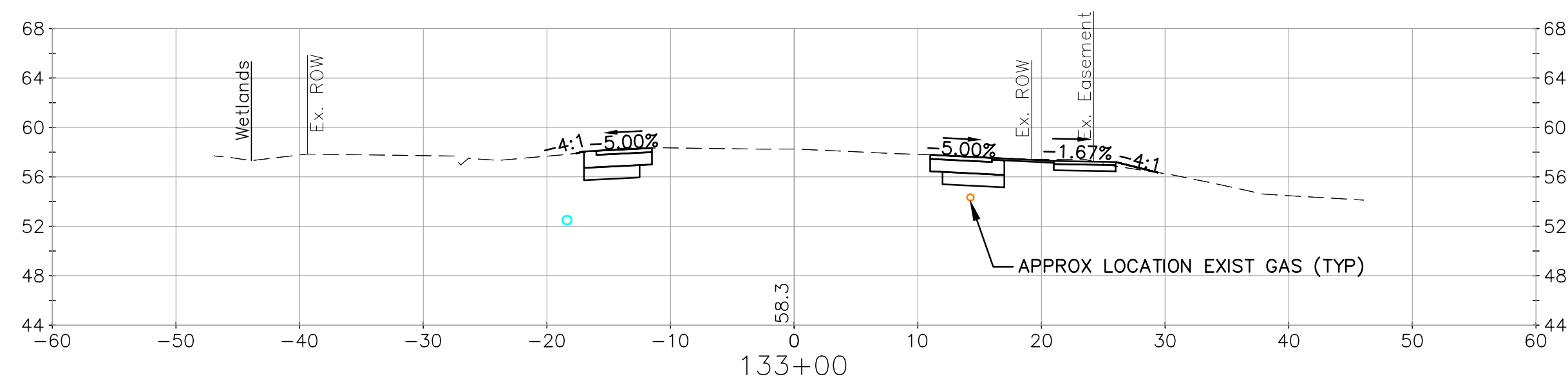
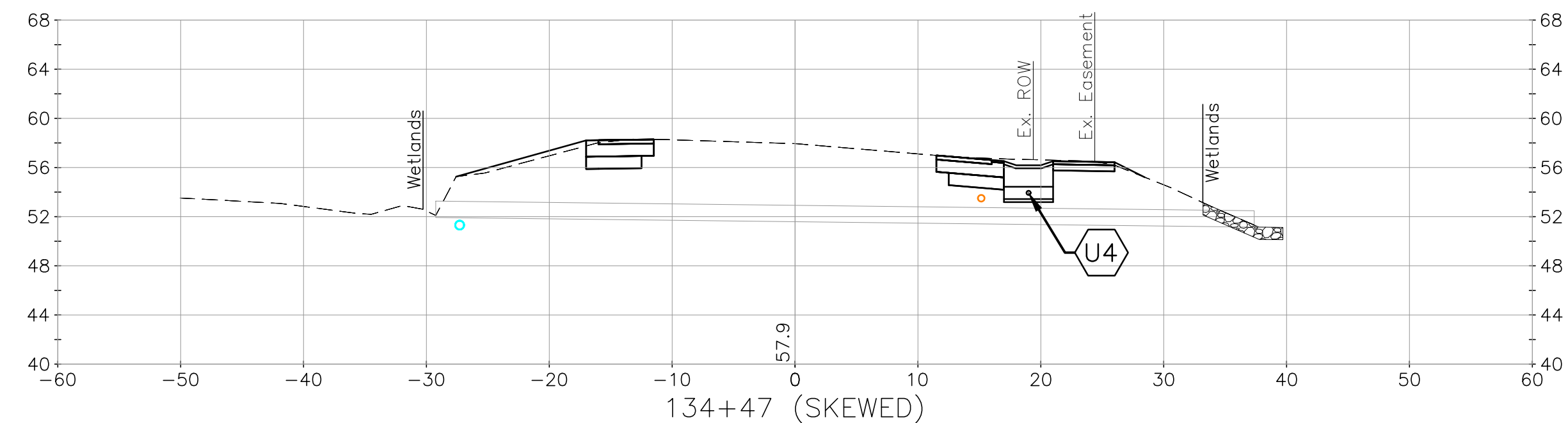
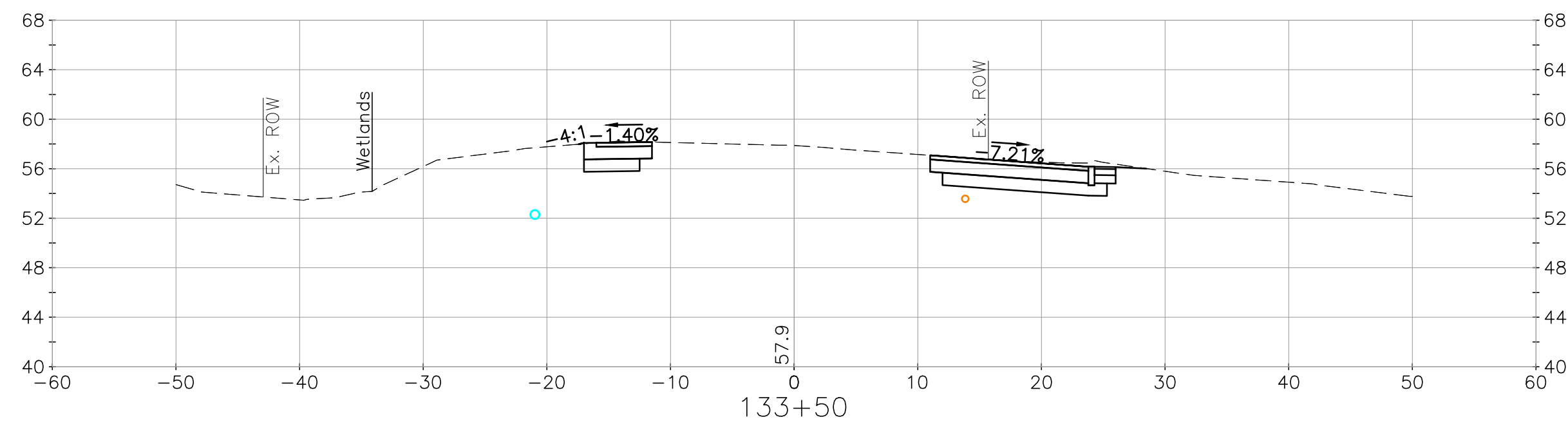
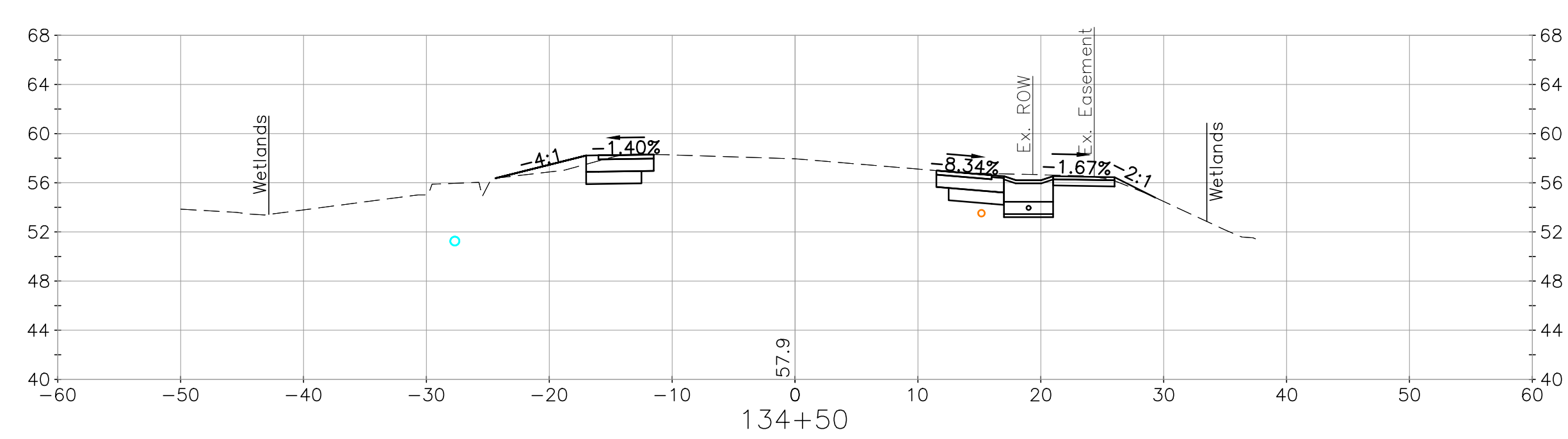
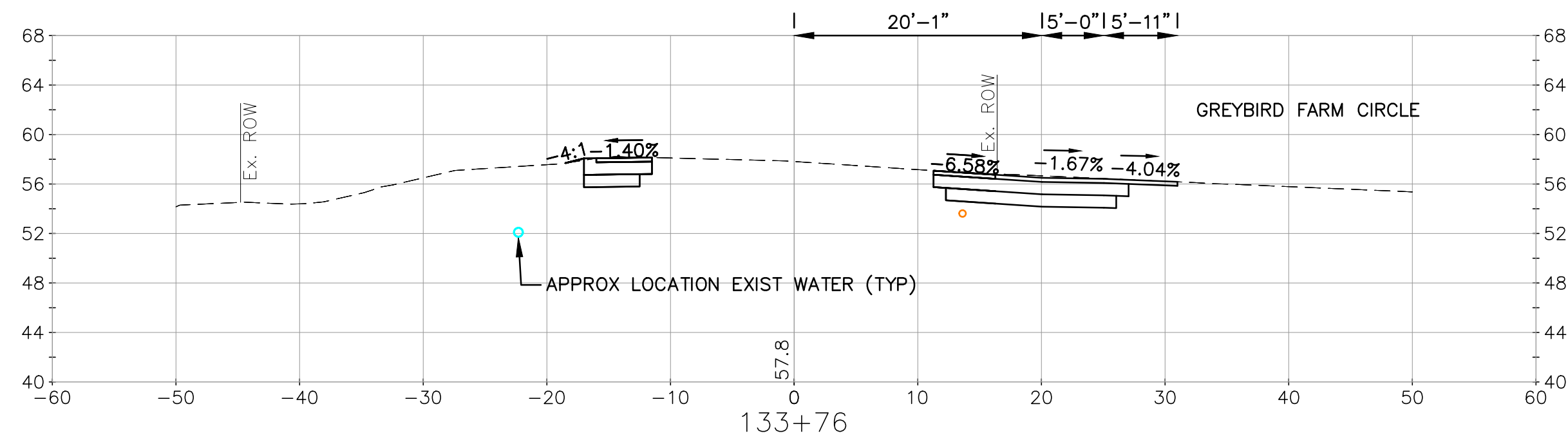
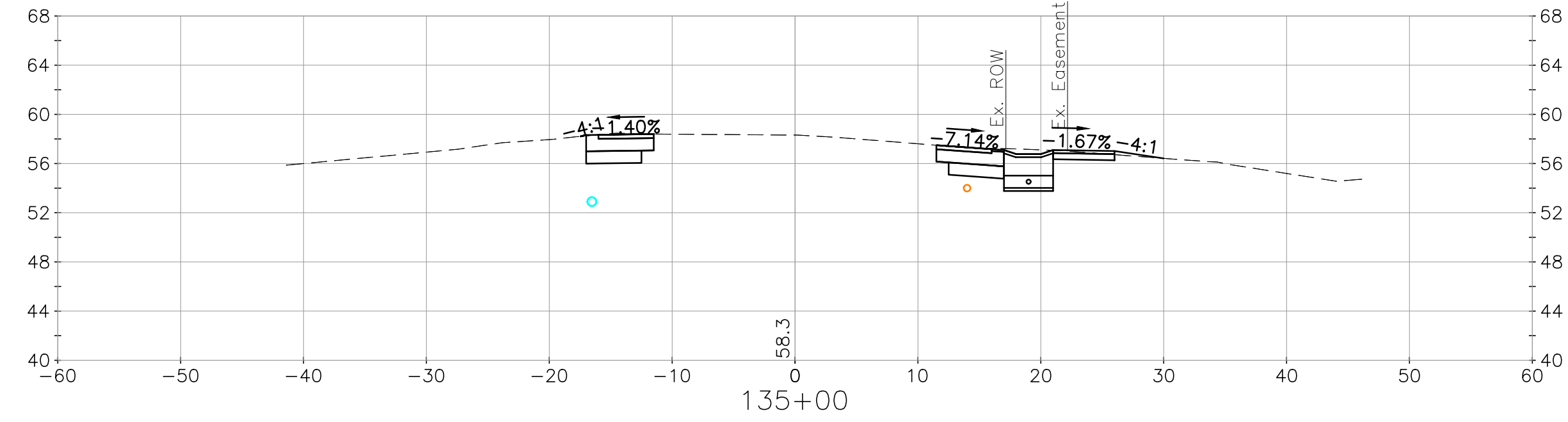
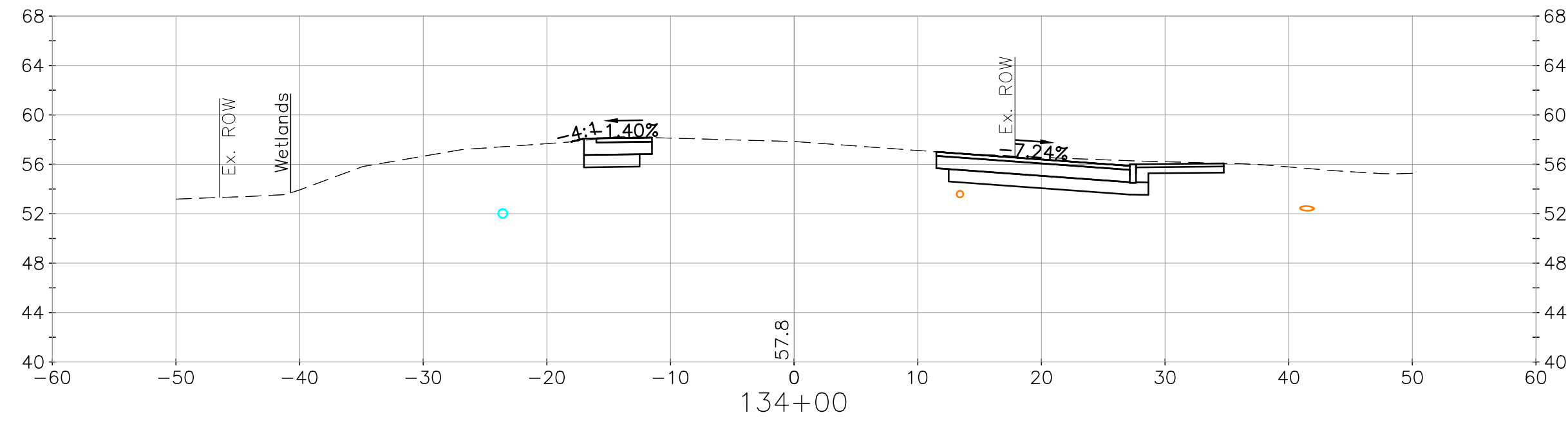

no.	1	Issued for Bidding	4/3/2023	JJB
revision			date	by

CMA ENGINEERS
 CIVIL/ENVIRONMENTAL/STRUCTURAL
 Portsmouth, NH • Manchester, NH • Portland, ME
 603/431-6196 • 603/627-0708 • 207/541-4223
 c m a e n g i n e e r s . c o m



date:	April 2023
designed by:	JJB/STF
project no.:	1030
drawn by:	ATR/STF
file name:	1030-Sections.dwg
approved by:	JJB

Town of Exeter, New Hampshire
 Public Works Department
 Kingston Road TAP Project
 Exeter 40436, X-A004(406)
 Cross Sections
 STA 133+00 to STA 135+00

drawing no.
XS-12
 sheet: 35 of 42

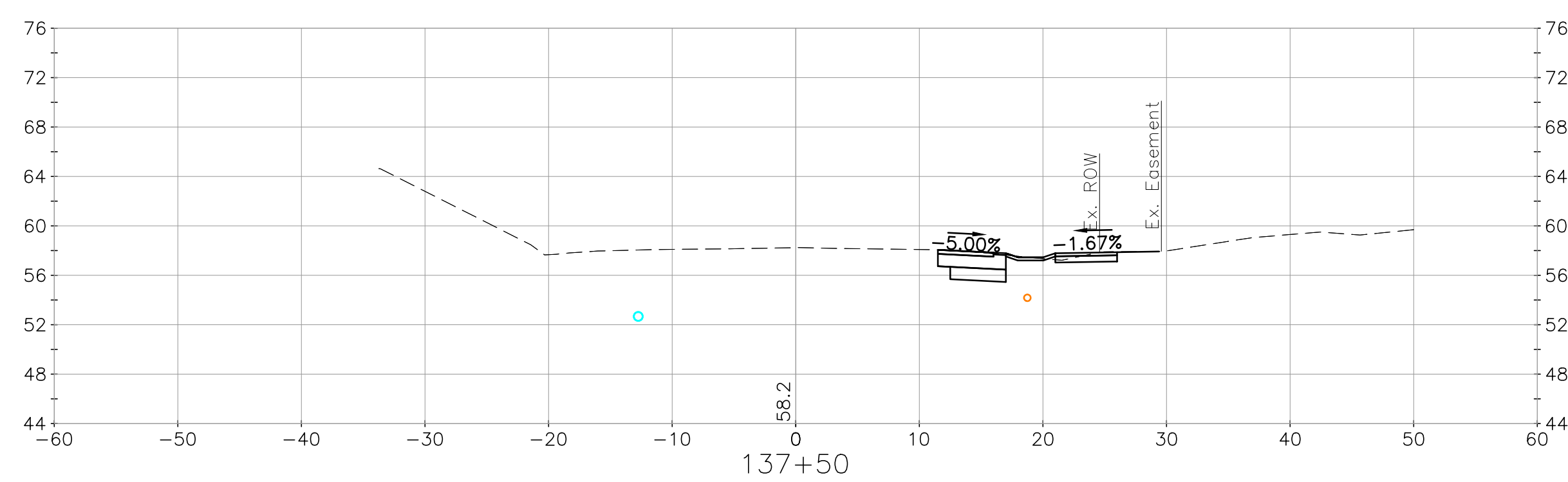
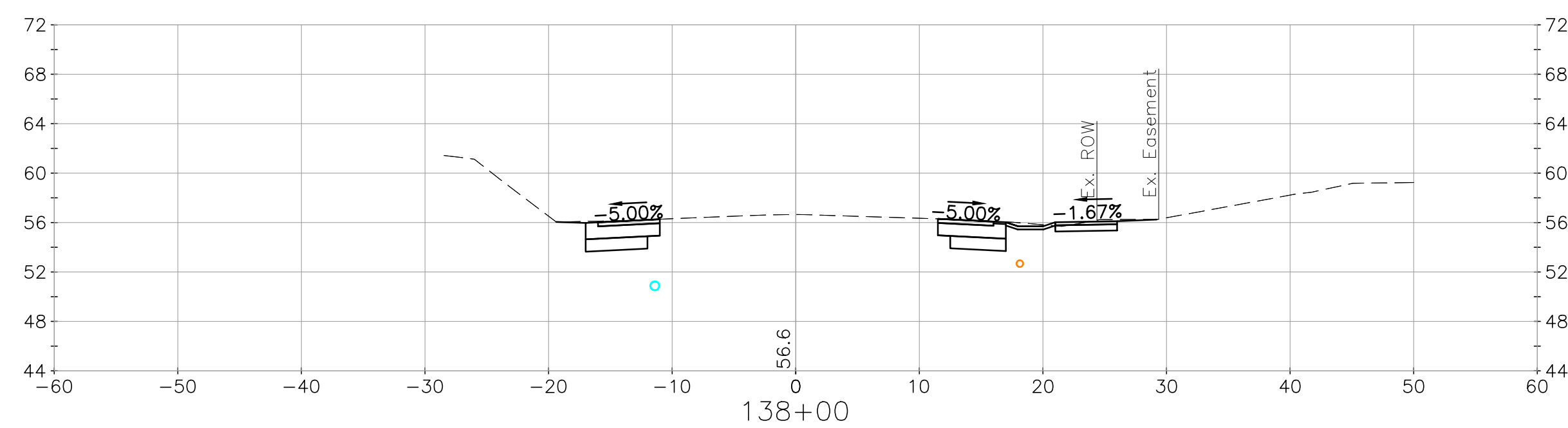
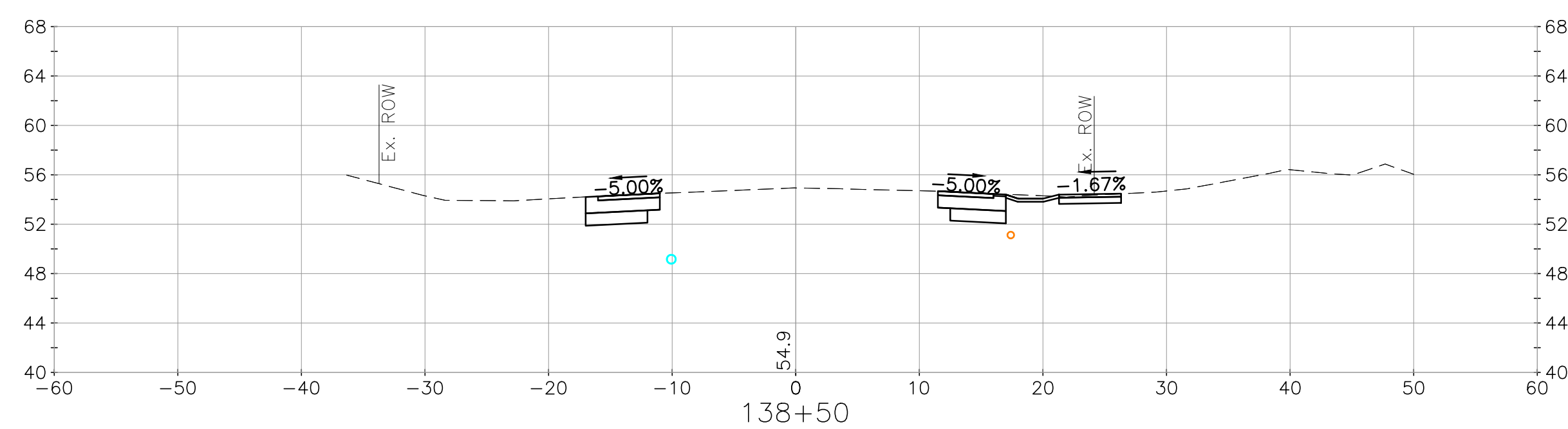
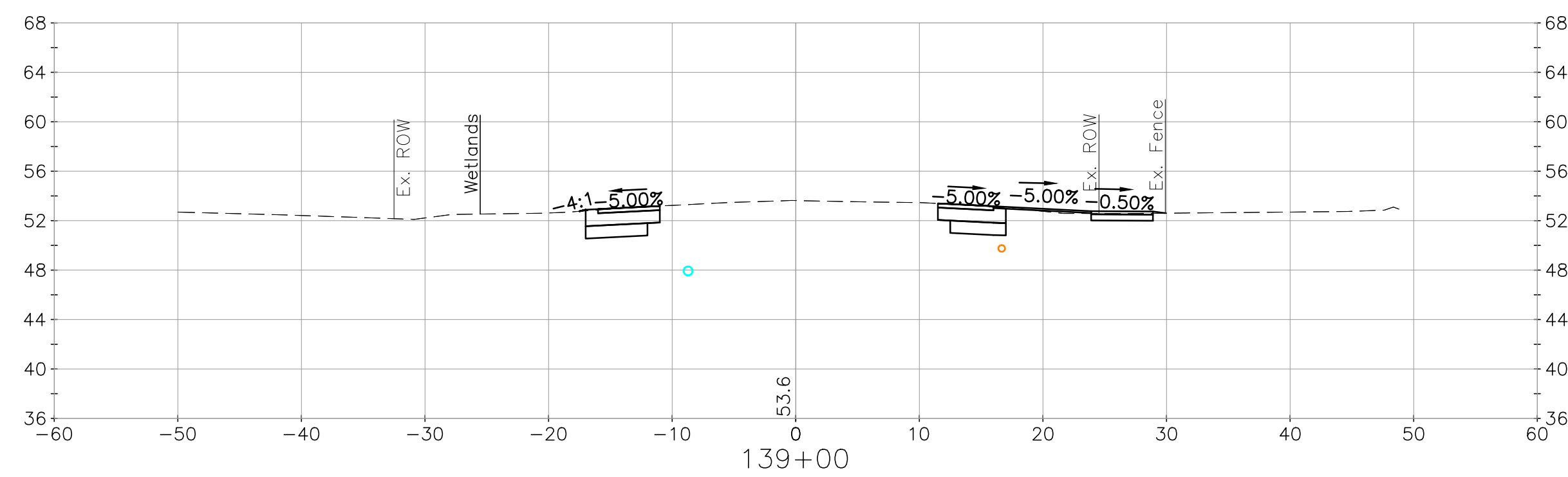
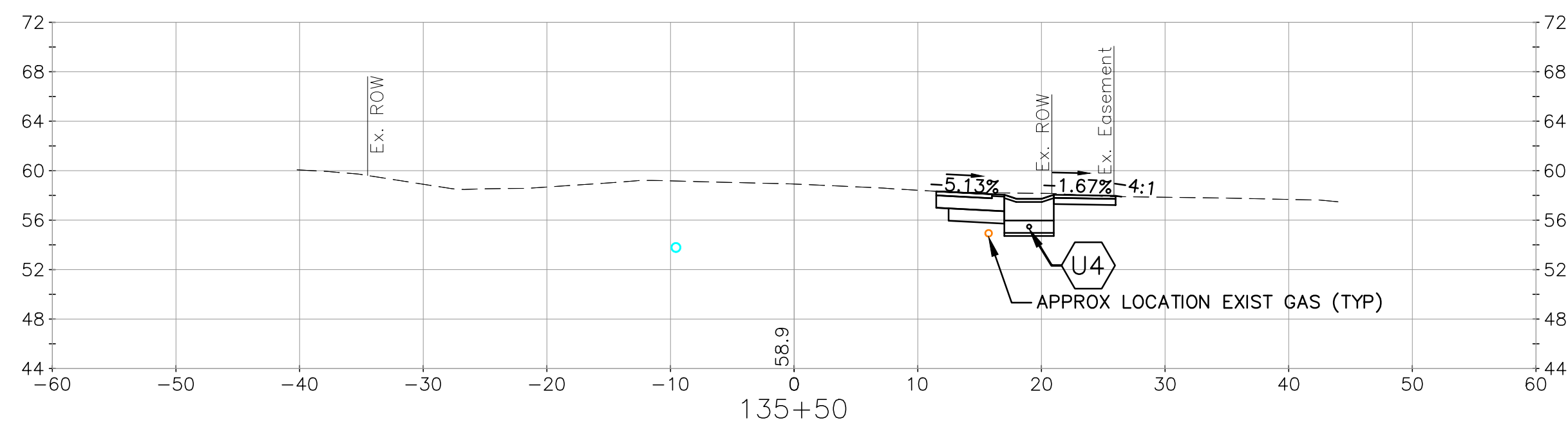
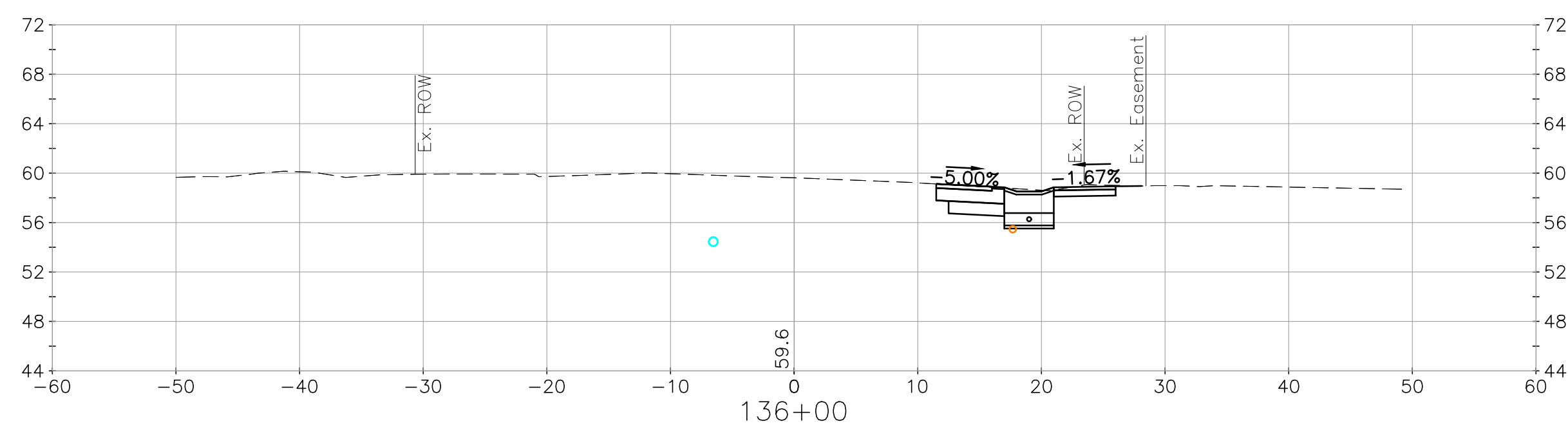
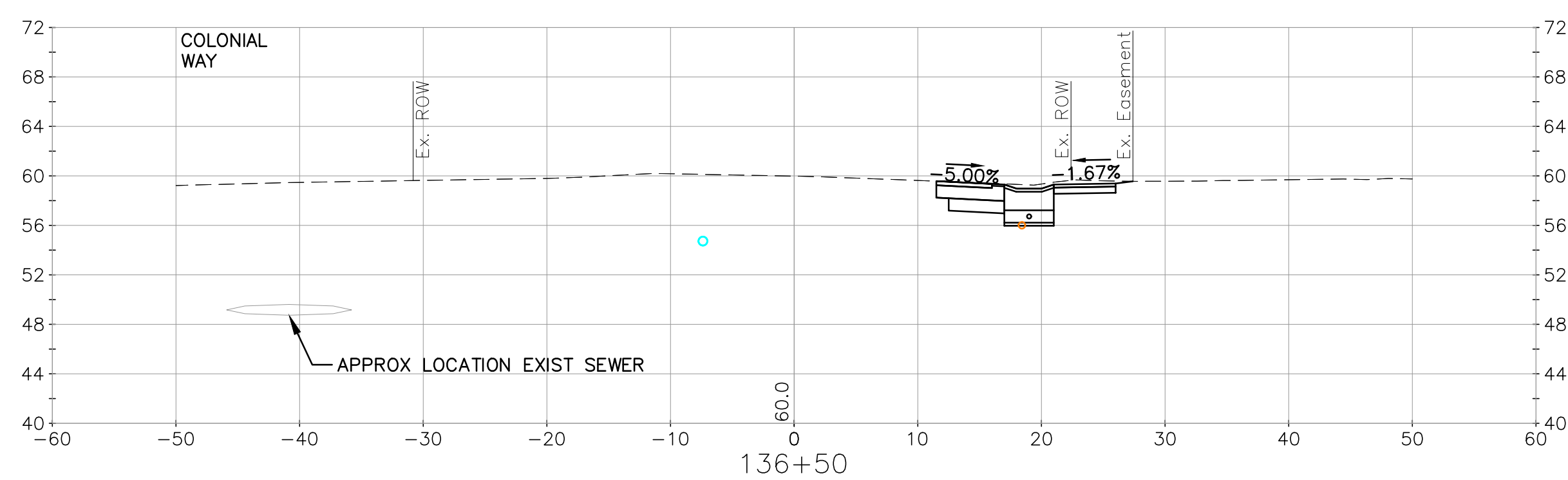
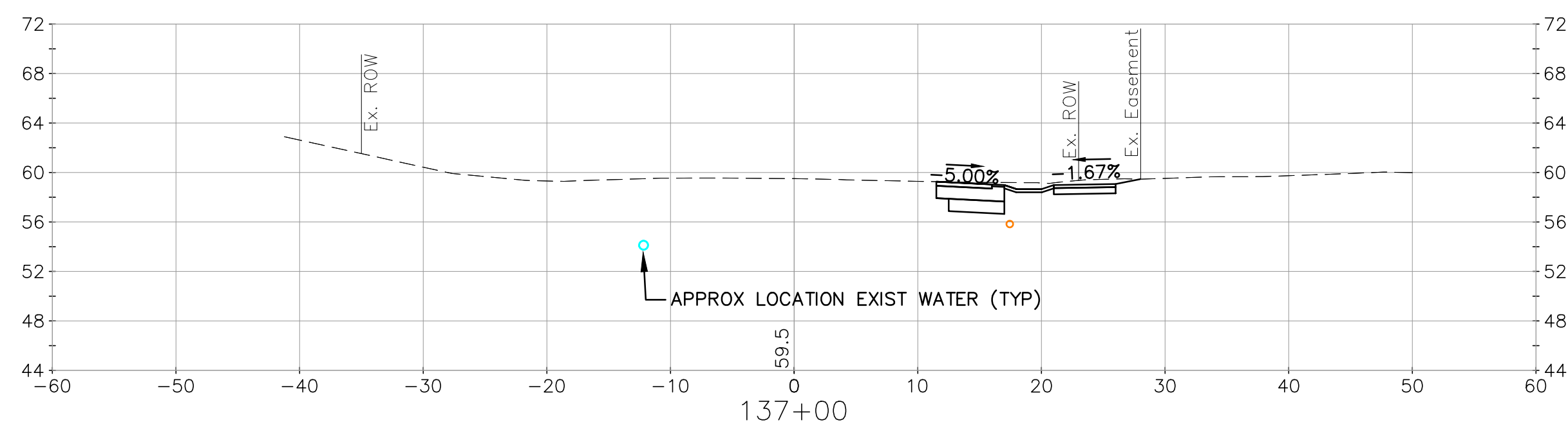

no.	1	revision	Issued for Bidding	date	4/3/2023	JJB	by
-----	---	----------	--------------------	------	----------	-----	----

CMA ENGINEERS
 CIVIL/ENVIRONMENTAL/STRUCTURAL
 Portsmouth, NH • Manchester, NH • Portland, ME
 603/431-6196 • 603/627-0708 • 207/541-4223
 c m a e n g i n e e r s . c o m

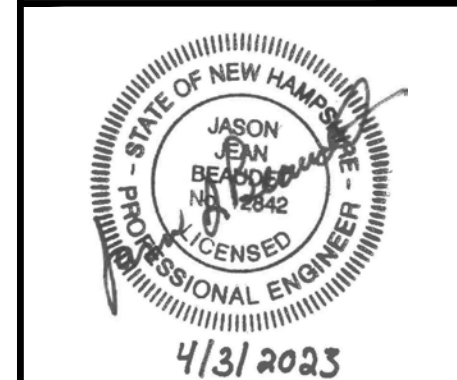

date:	April 2023	designed by:	JJB/STF
project no.:	1030	drawn by:	ATR/STF
file name:	1030-Sections.dwg	approved by:	JJB

scale: 1" = 10'
 0 10' 20'

Town of Exeter, New Hampshire
 Public Works Department
 Kingston Road TAP Project
 Exeter 40436, X-A004(406)
 Cross Sections
 STA 135+50 to STA 139+00

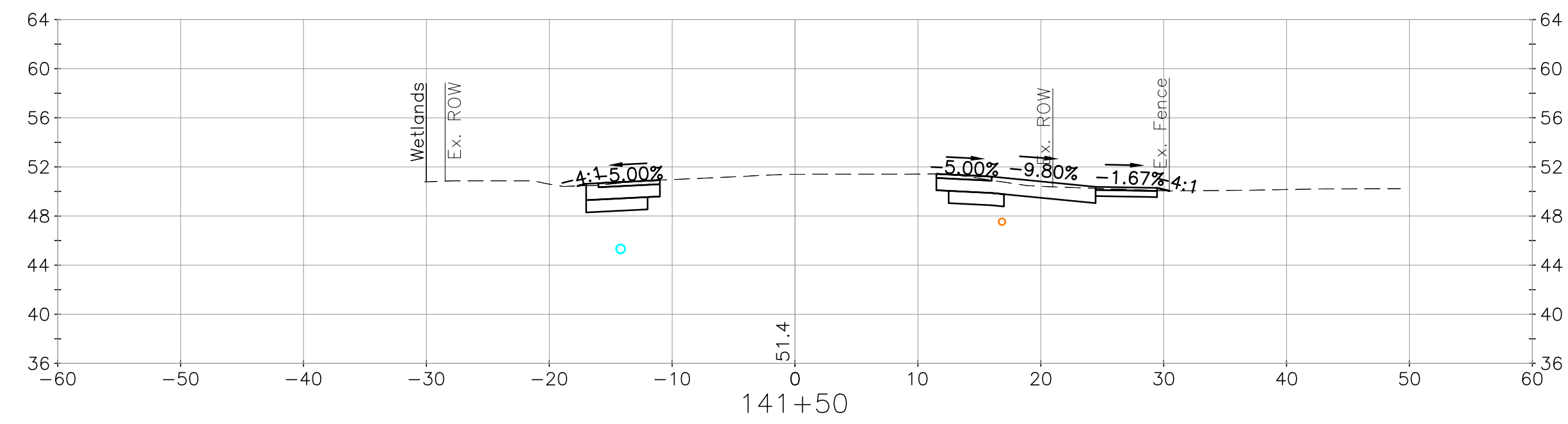
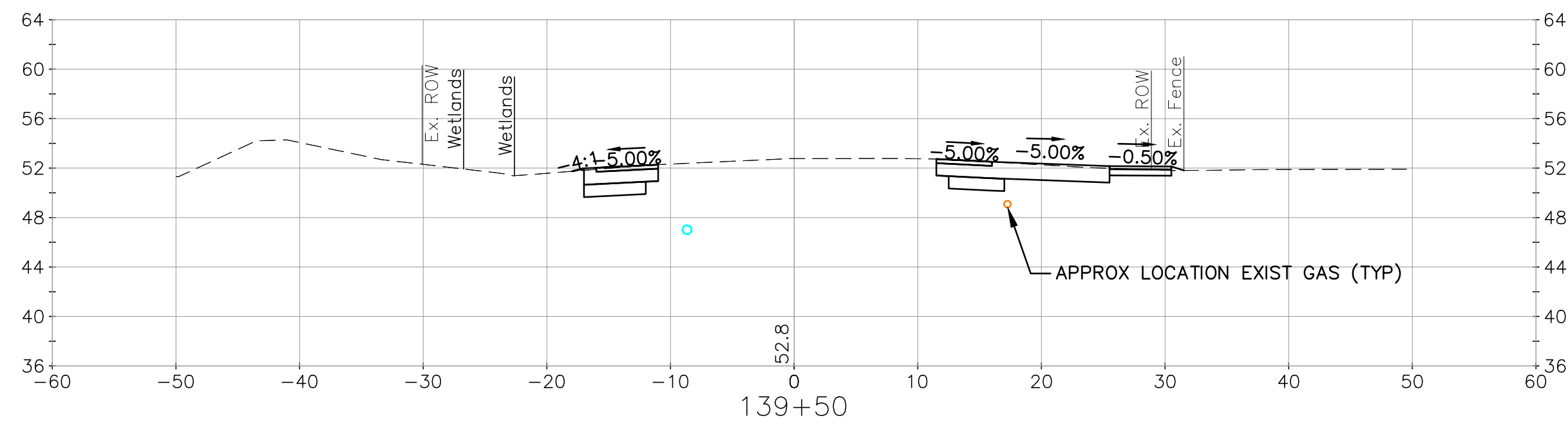
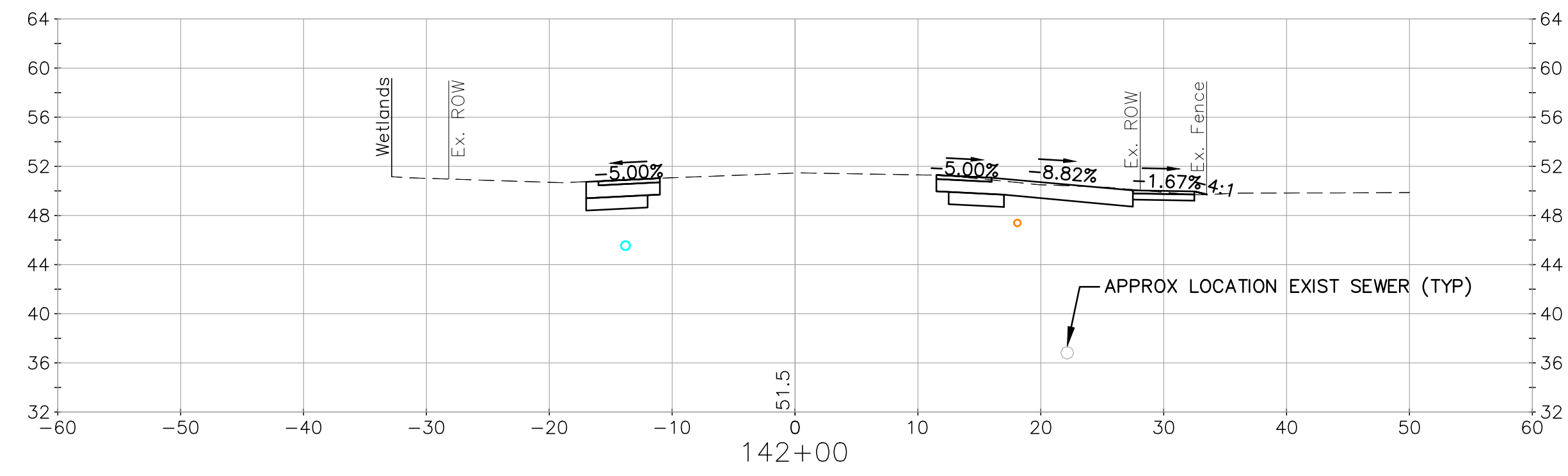
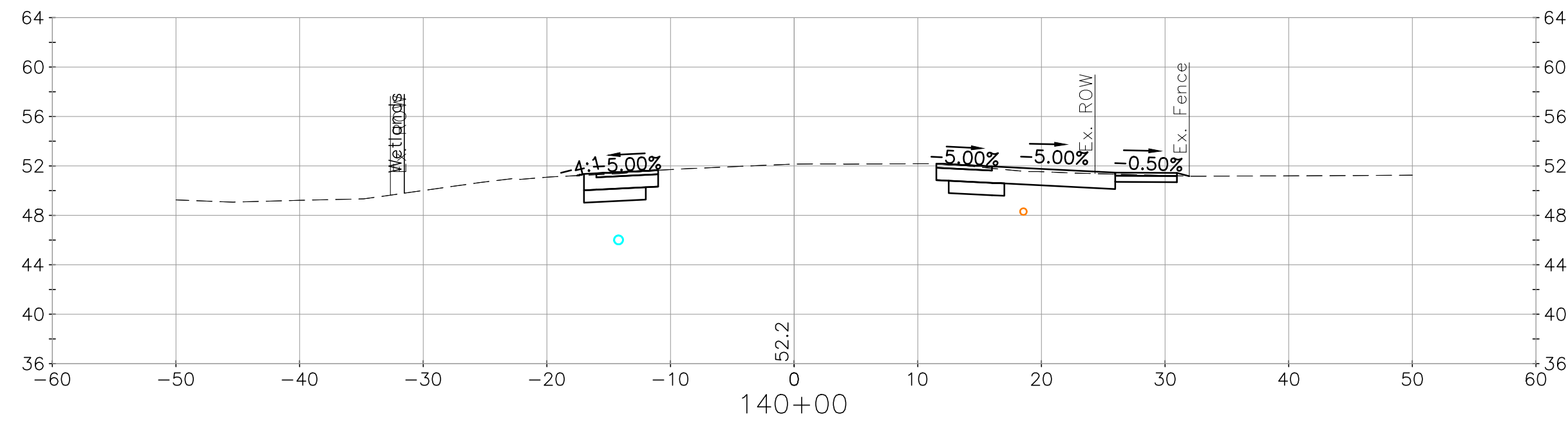
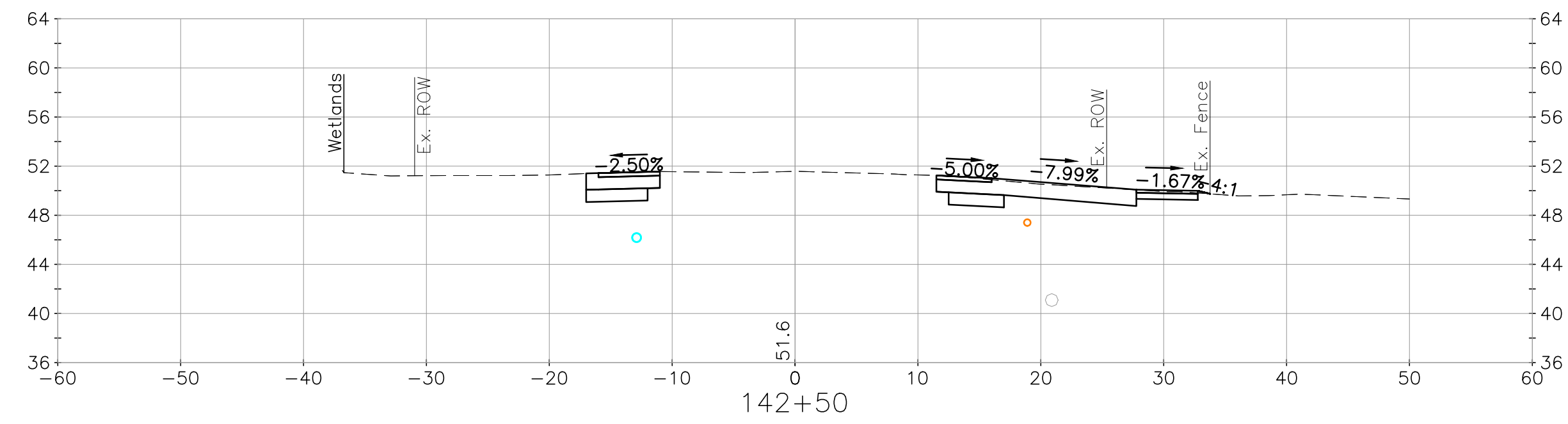
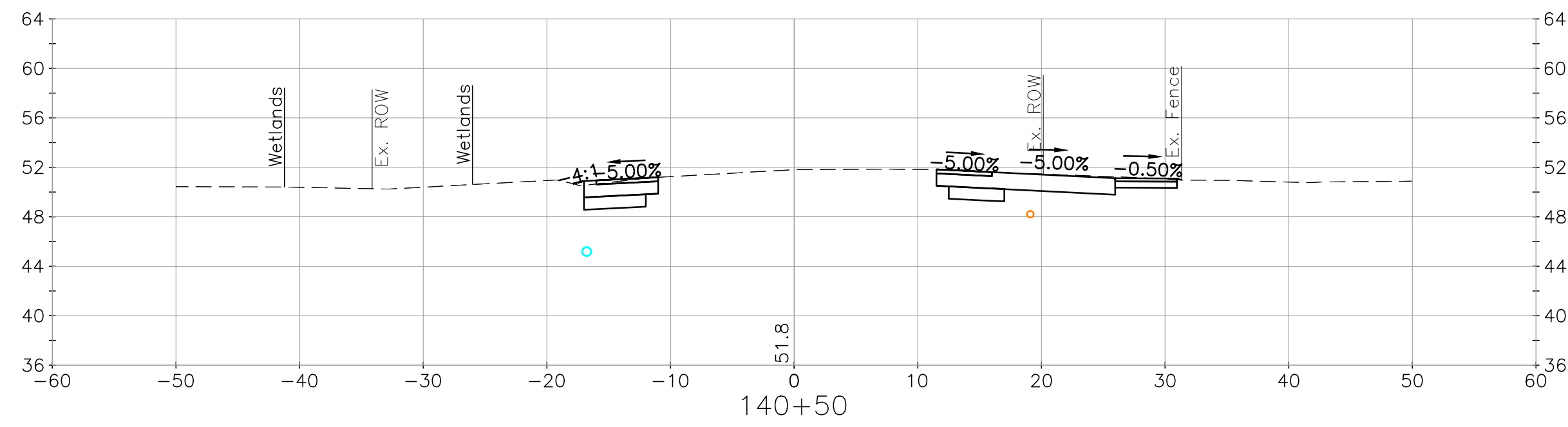
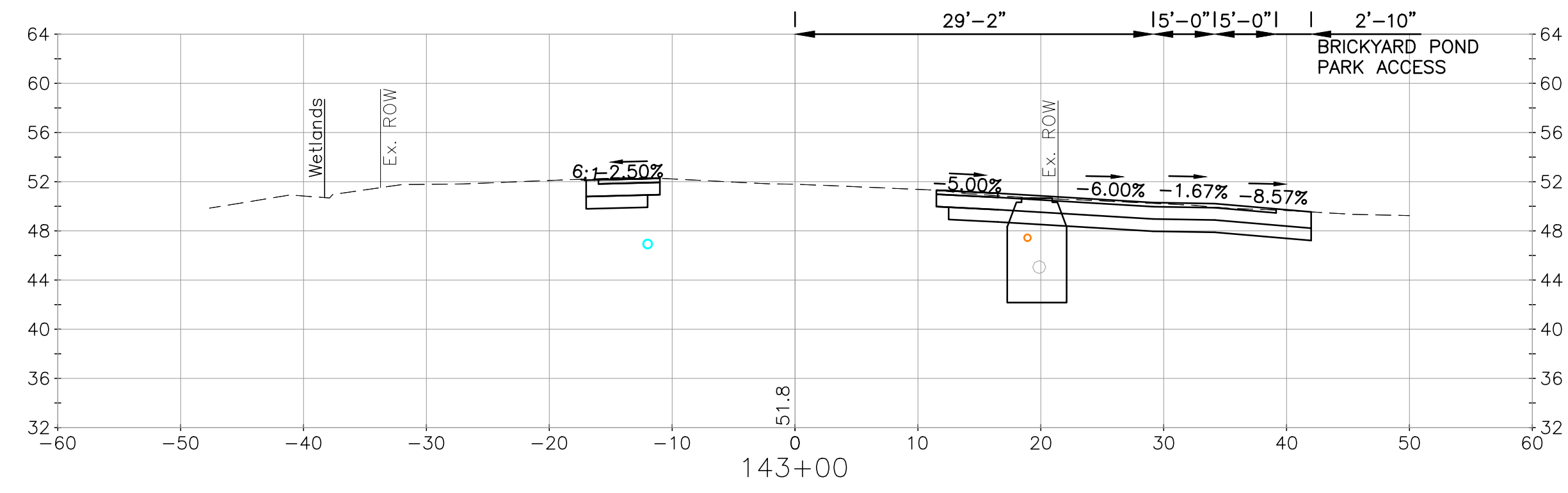
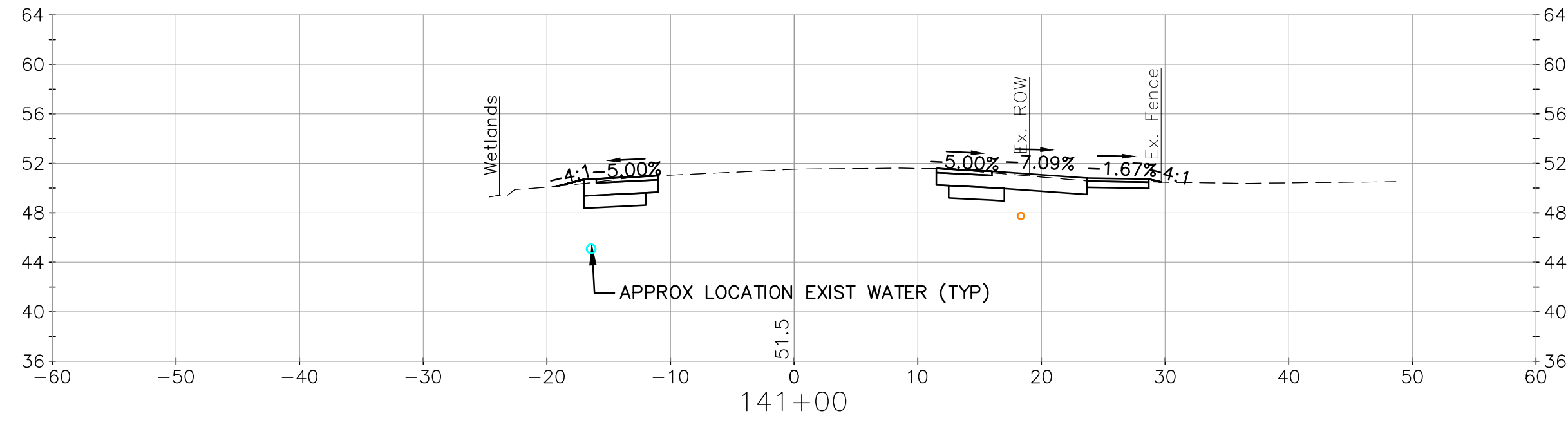

no.	1	revision	Issued for Bidding	date	4/3/2023	JUB	by
-----	---	----------	--------------------	------	----------	-----	----

CMA ENGINEERS
 CIVIL/ENVIRONMENTAL/STRUCTURAL
 Portsmouth, NH • Manchester, NH • Portland, ME
 603/431-6196 • 603/627-0708 • 207/541-4223
 c m a e n g i n e e r s . c o m



date:	April 2023	designed by:	JUB/STF
project no.:	1030	drawn by:	ATP/STF
file name:	1030-Sections.dwg	approved by:	JUB

Scale: 1" = 10'
 0 10' 20'

Town of Exeter, New Hampshire
 Public Works Department
 Kingston Road TAP Project
 Exeter 40436, X-A004(406)
 Cross Sections
 STA 139+50 to STA 143+00

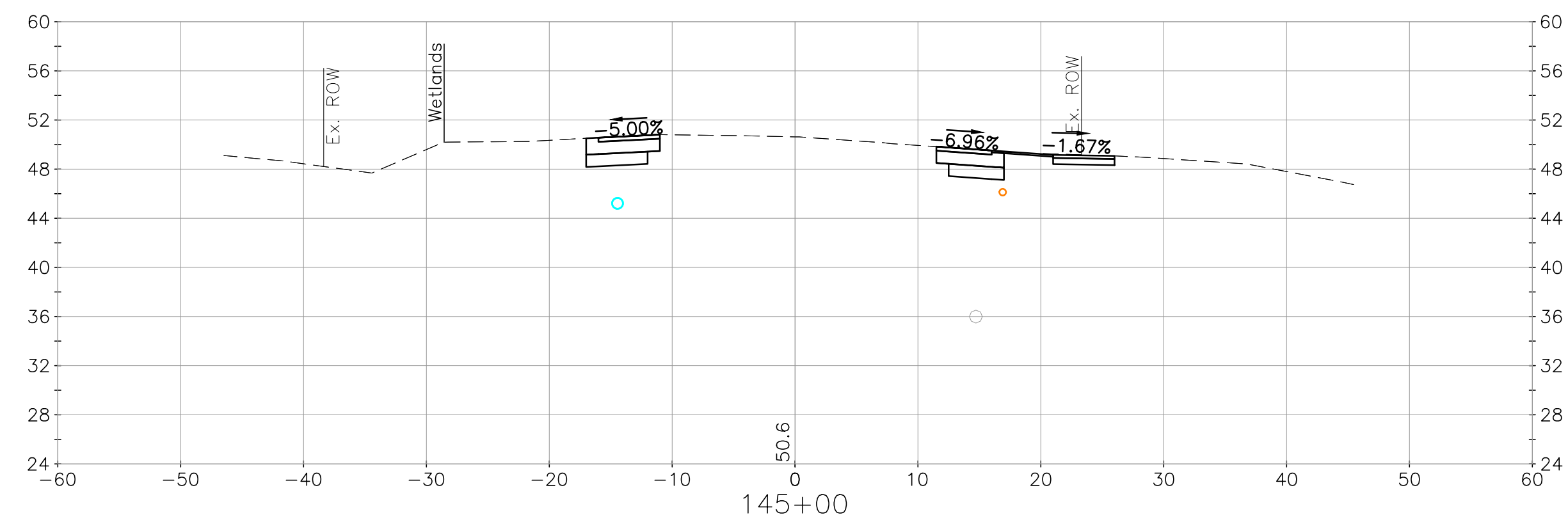
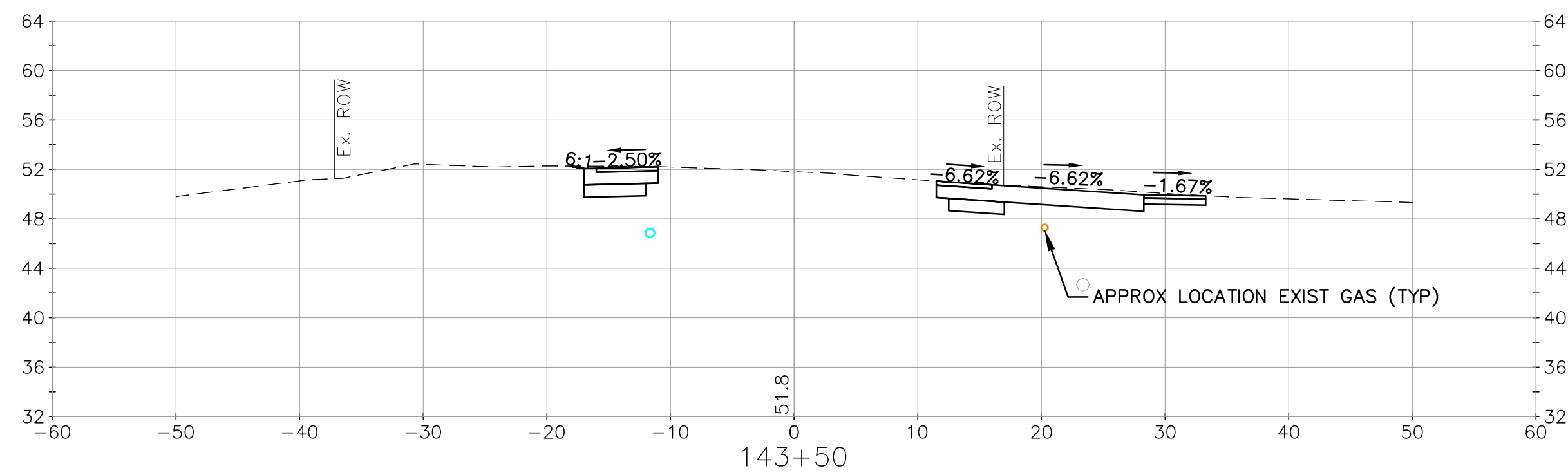
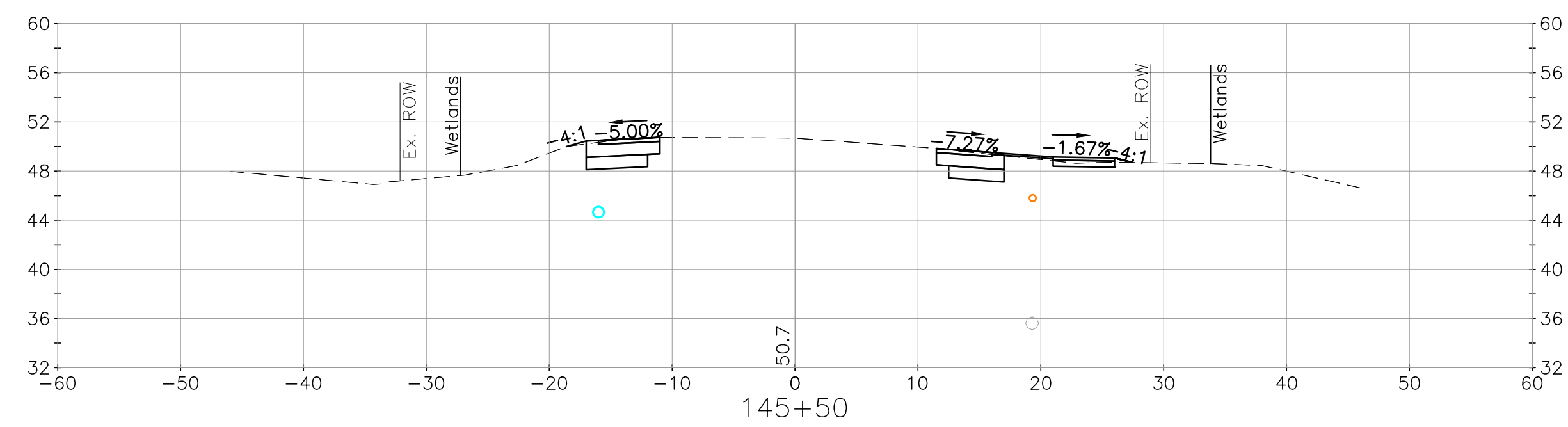
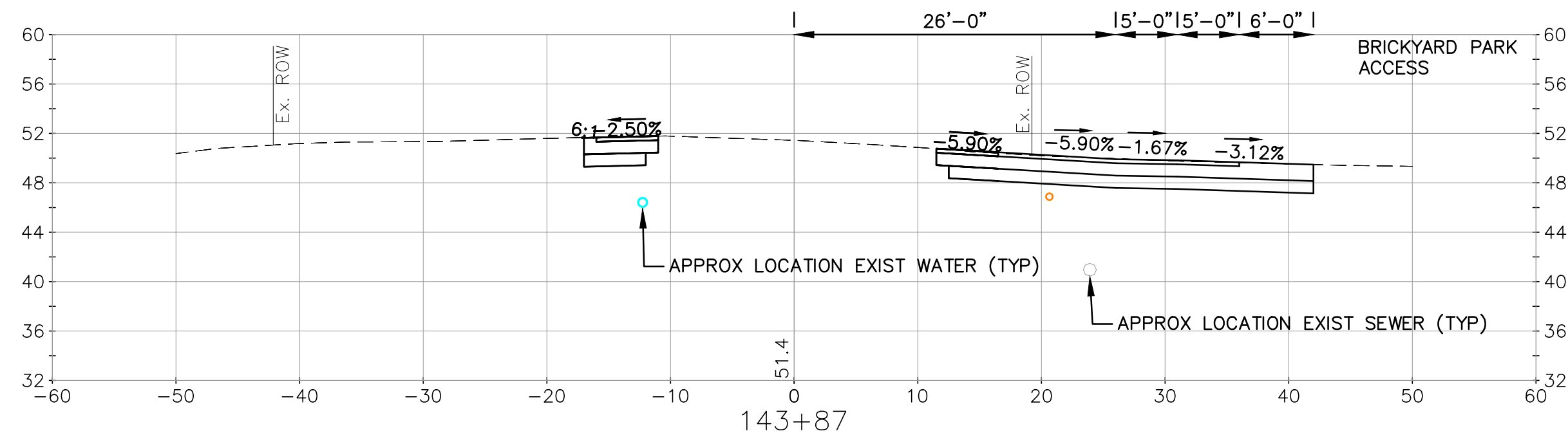
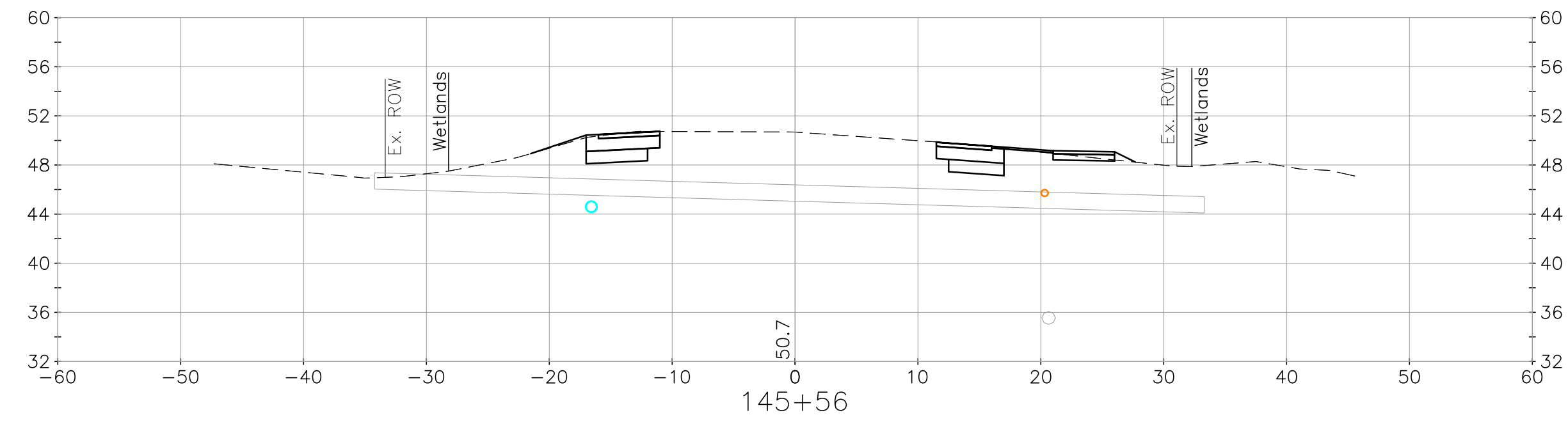
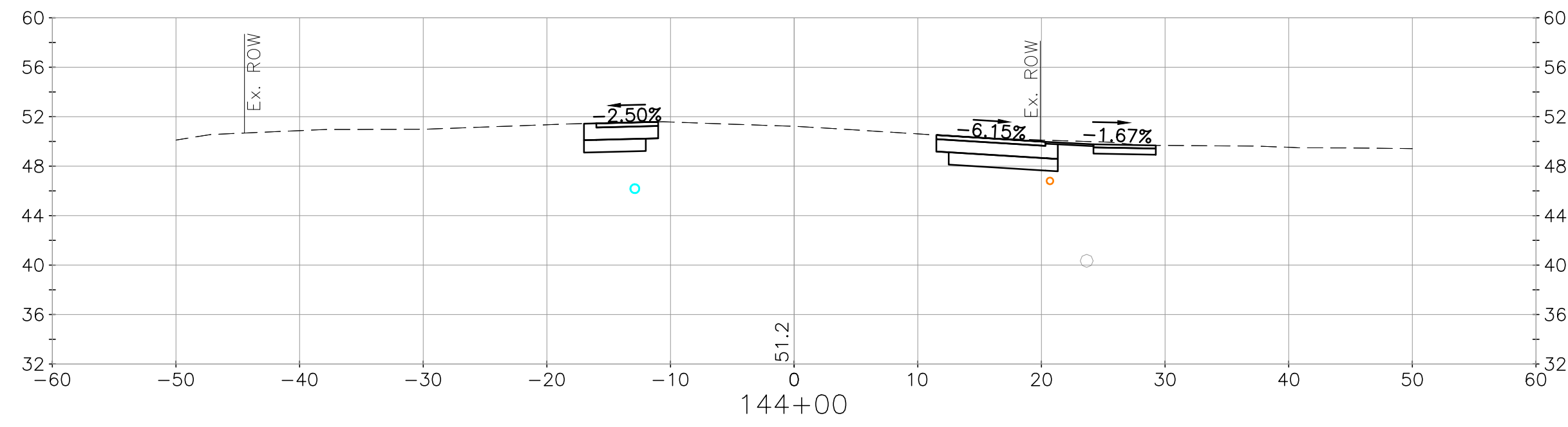
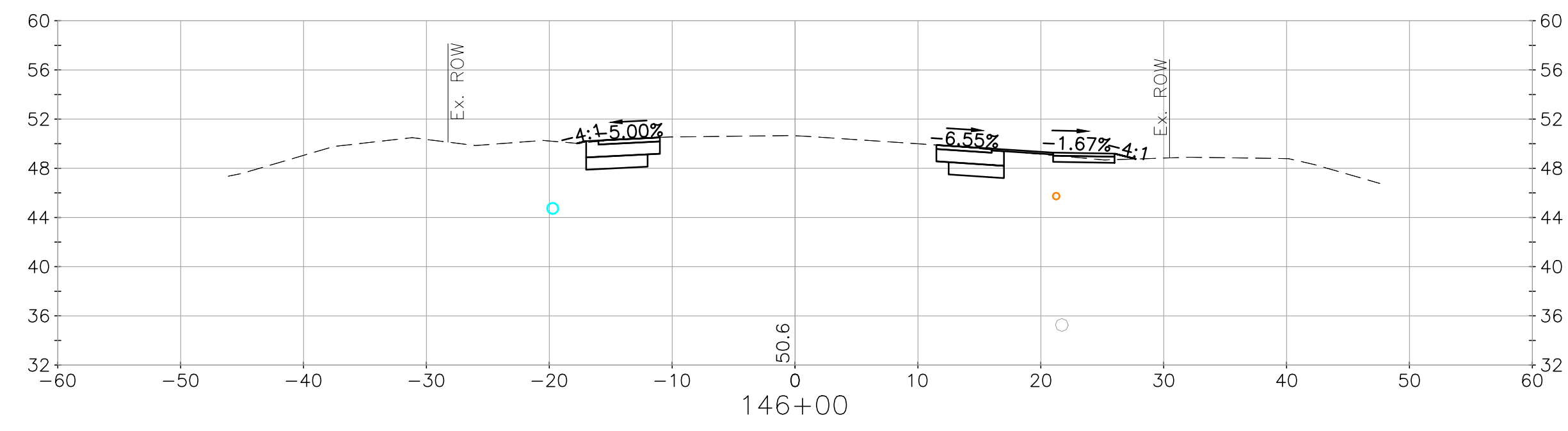
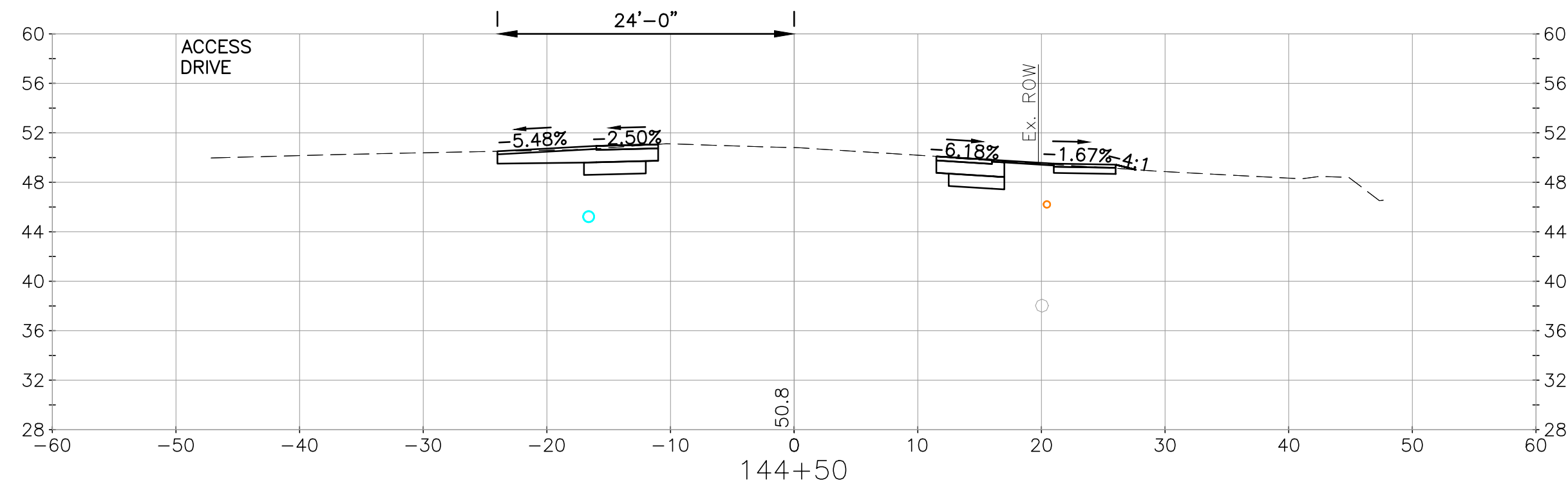

no.	1	Issued for Bidding	4/3/2023	JJB
revision			date	by

CMA ENGINEERS
 CIVIL/ENVIRONMENTAL/STRUCTURAL
 Portsmouth, NH • Manchester, NH • Portland, ME
 603/431-6196 • 603/627-0708 • 207/541-4223
 c m a e n g i n e e r s . c o m

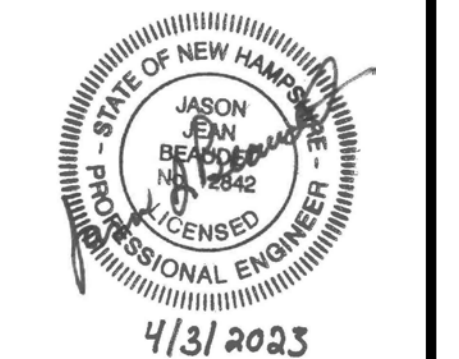

date:	April 2023	designed by:	JJB/STF
project no.:	1030	drawn by:	ATP/STF
file name:	1030-Sections.dwg	approved by:	JJB

scale: 1" = 10'
 0 10' 20'

Town of Exeter, New Hampshire
 Public Works Department
 Kingston Road TAP Project
 Exeter 40436, X-A004(406)
 Cross Sections
 STA 143+50 to STA 146+00

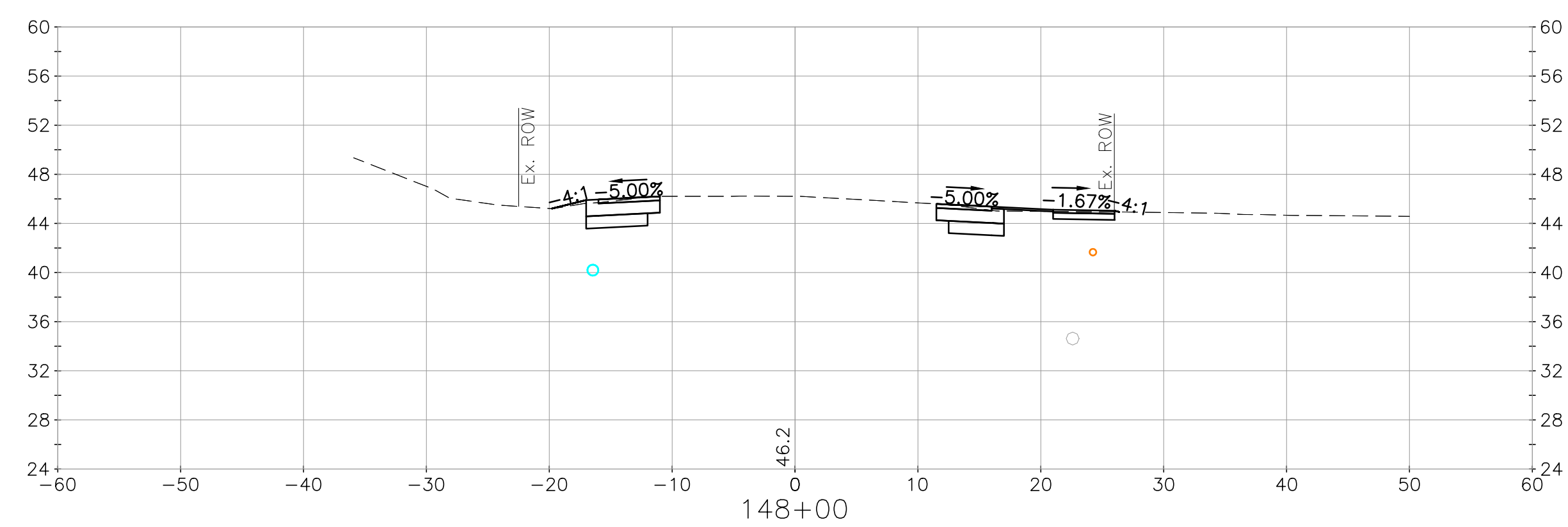
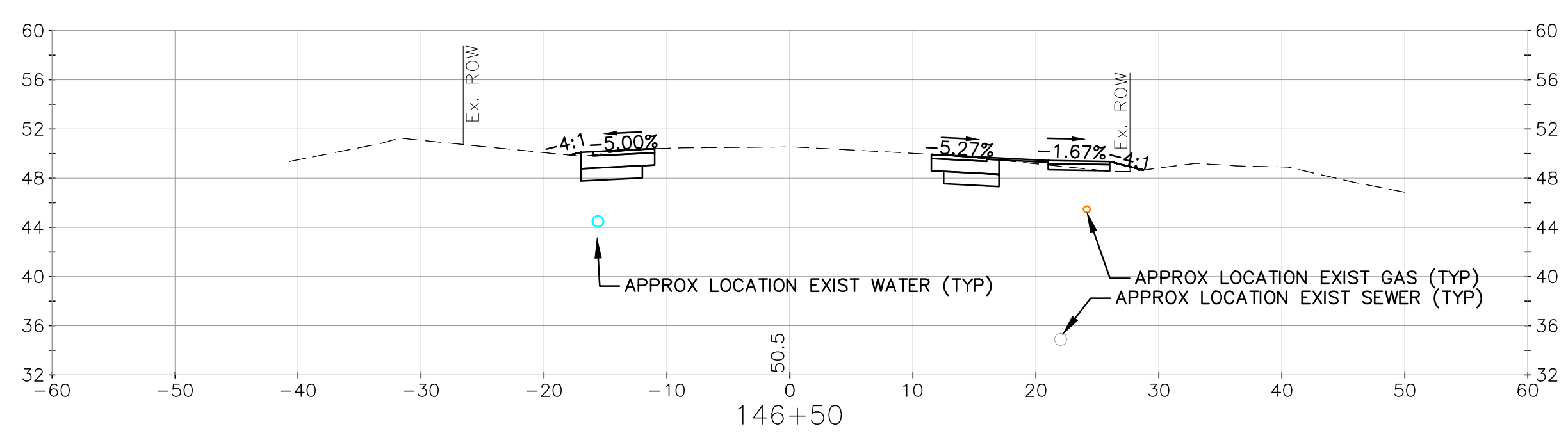
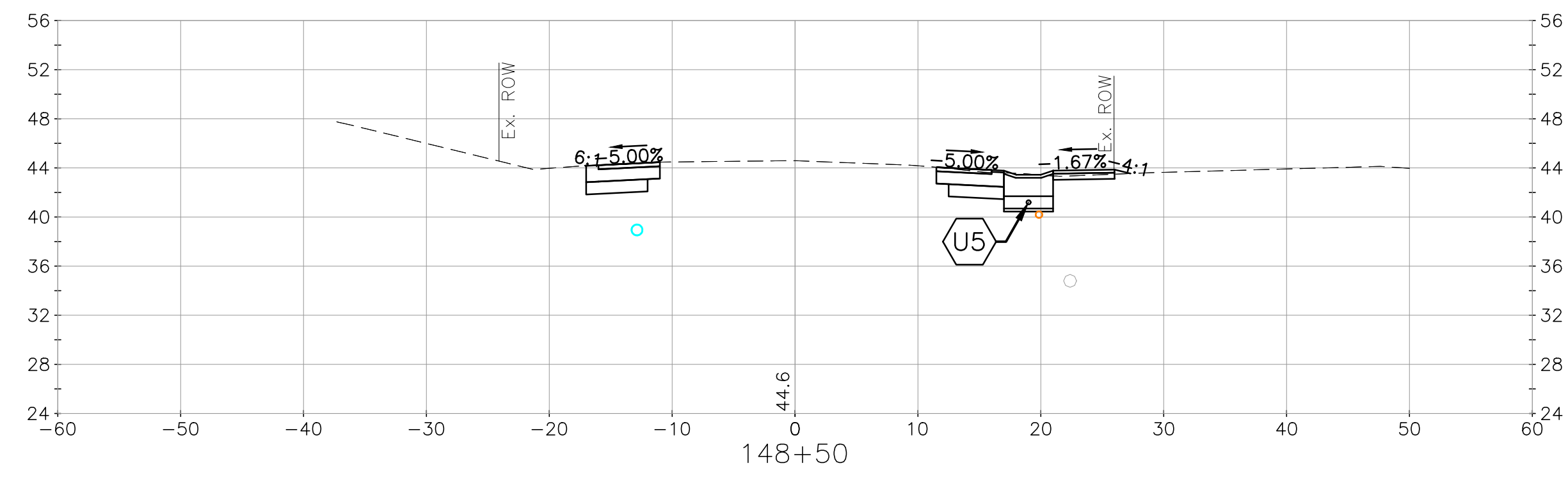
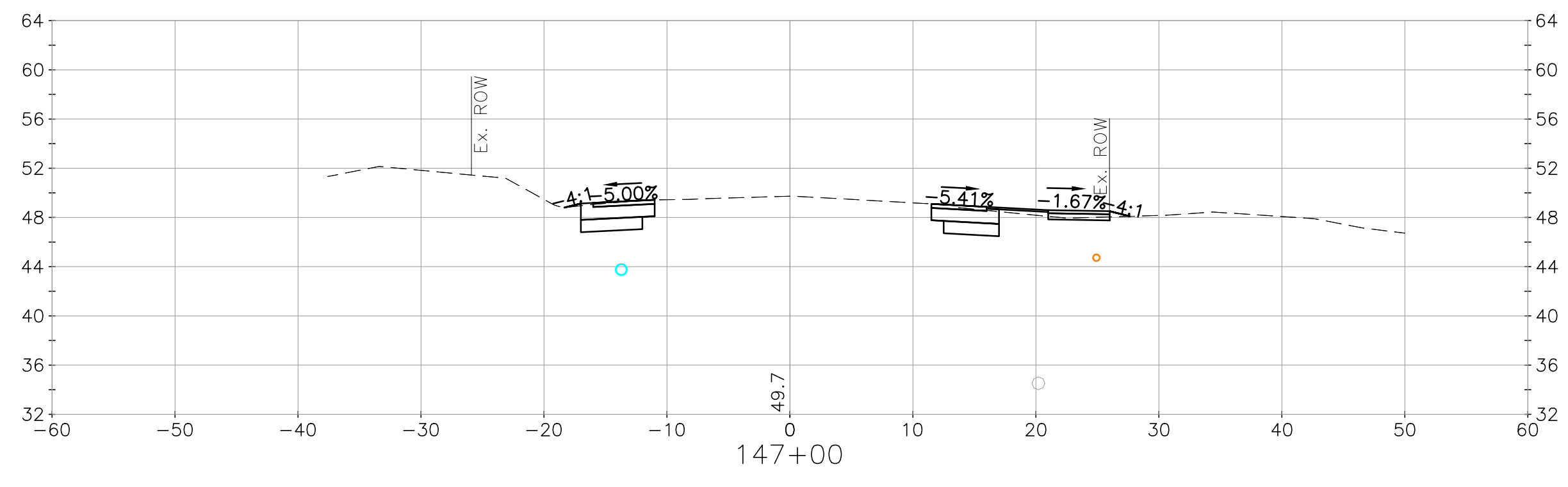
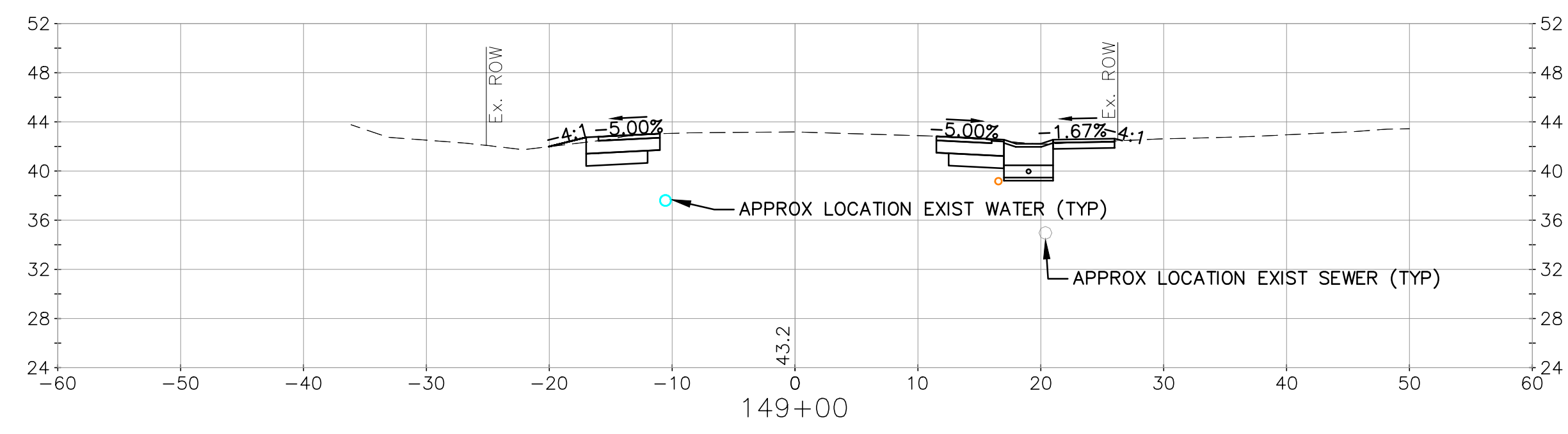
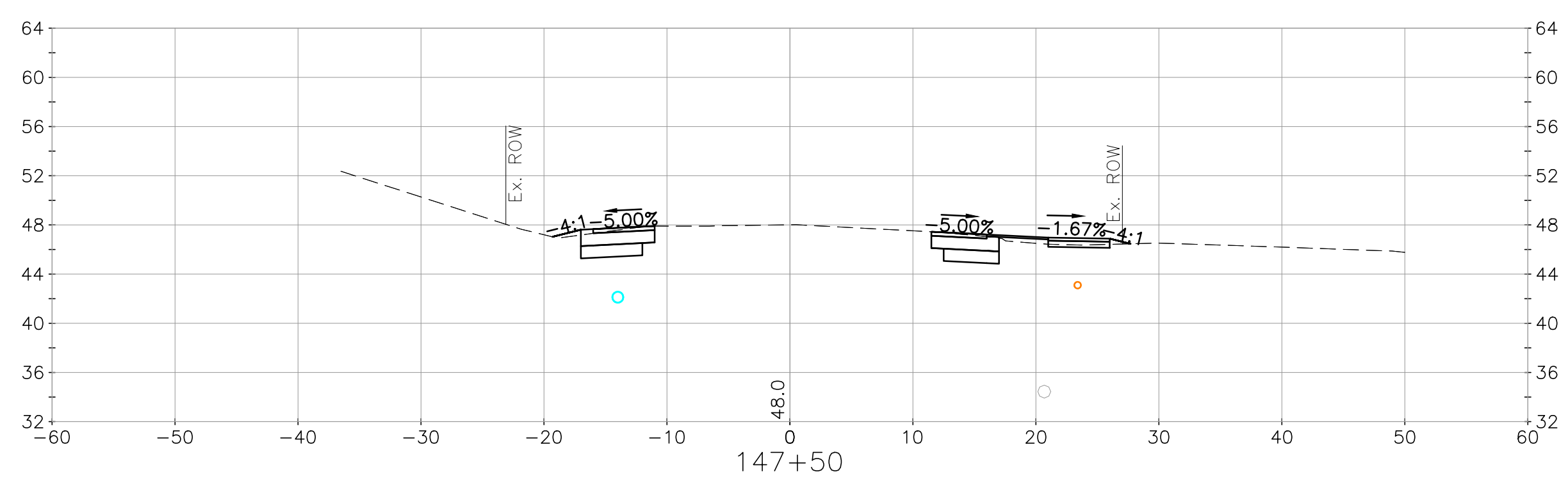
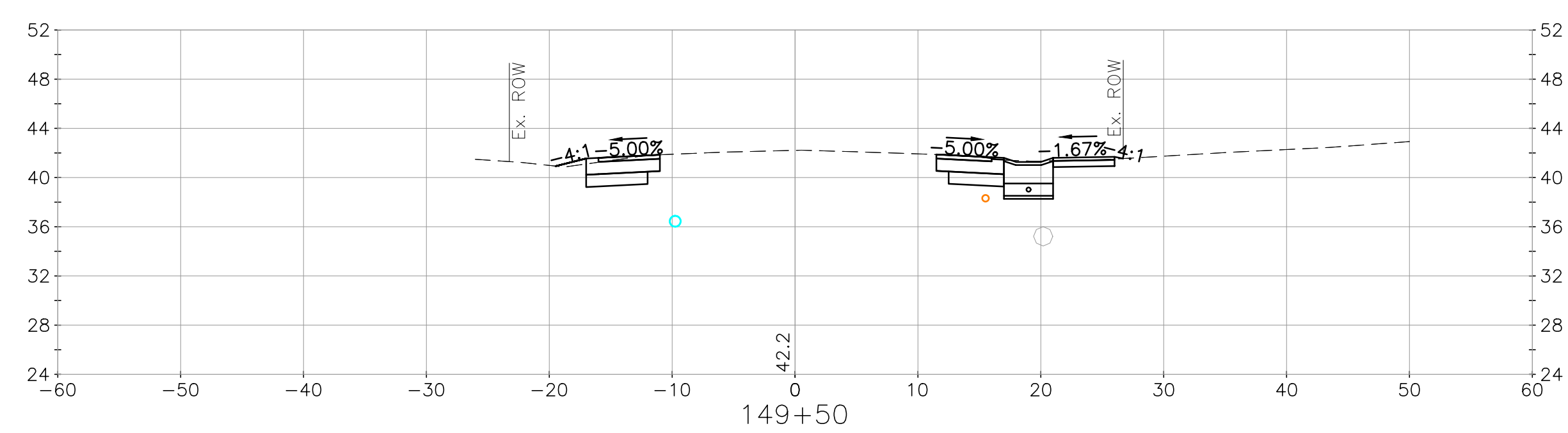
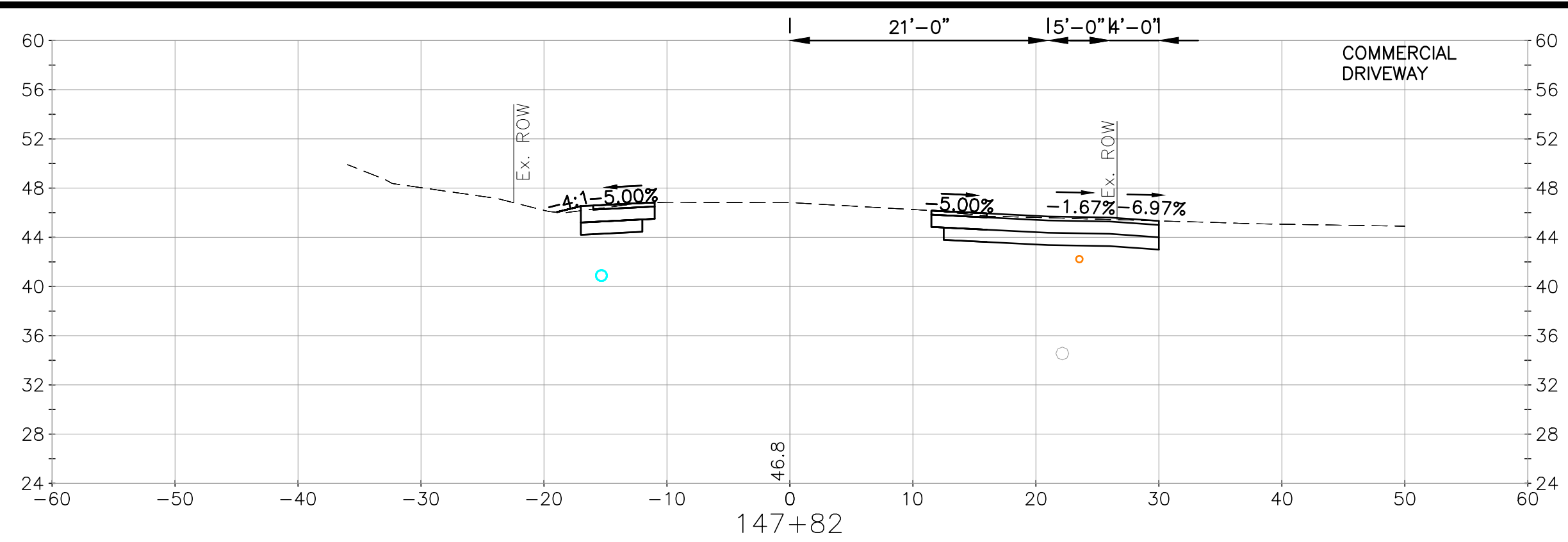

no.	1	Issued for Bidding	date	4/3/2023	JJB	by
revision						

CMA ENGINEERS
 CIVIL/ENVIRONMENTAL/STRUCTURAL
 Portsmouth, NH • Manchester, NH • Portland, ME
 603/431-6196 • 603/627-0708 • 207/541-4223
 c m a e n g i n e e r s . c o m

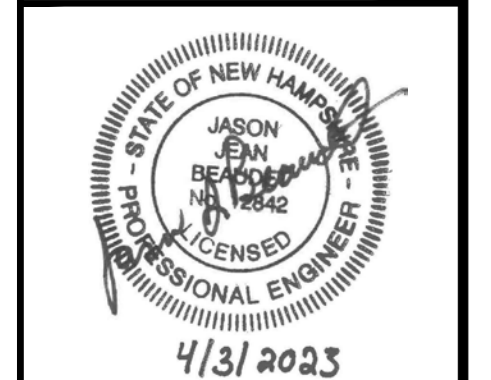

date:	April 2023	designed by:	JJB/STF
project no.:	1030	drawn by:	ATR/STF
file name:	1030-Sections.dwg	approved by:	JJB

scale: 1" = 10'
 0 10' 20'

Town of Exeter, New Hampshire
 Public Works Department
 Kingston Road TAP Project
 Exeter 40436, X-A004(406)
 Cross Sections
 STA 146+50 to STA 149+50

drawing no.
XS-16
 sheet: 39 of 42

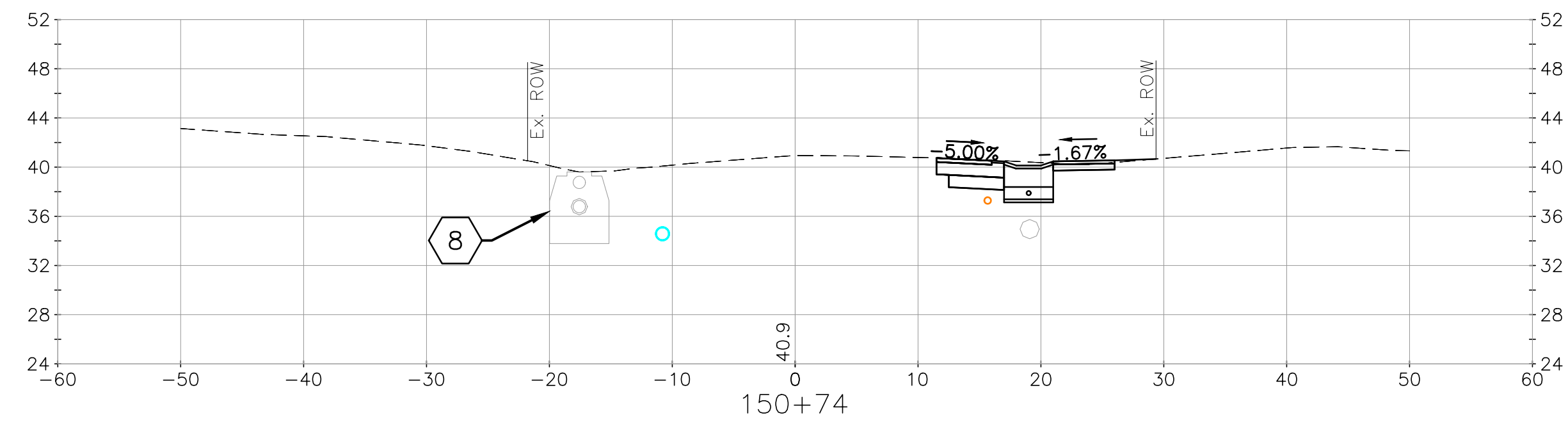
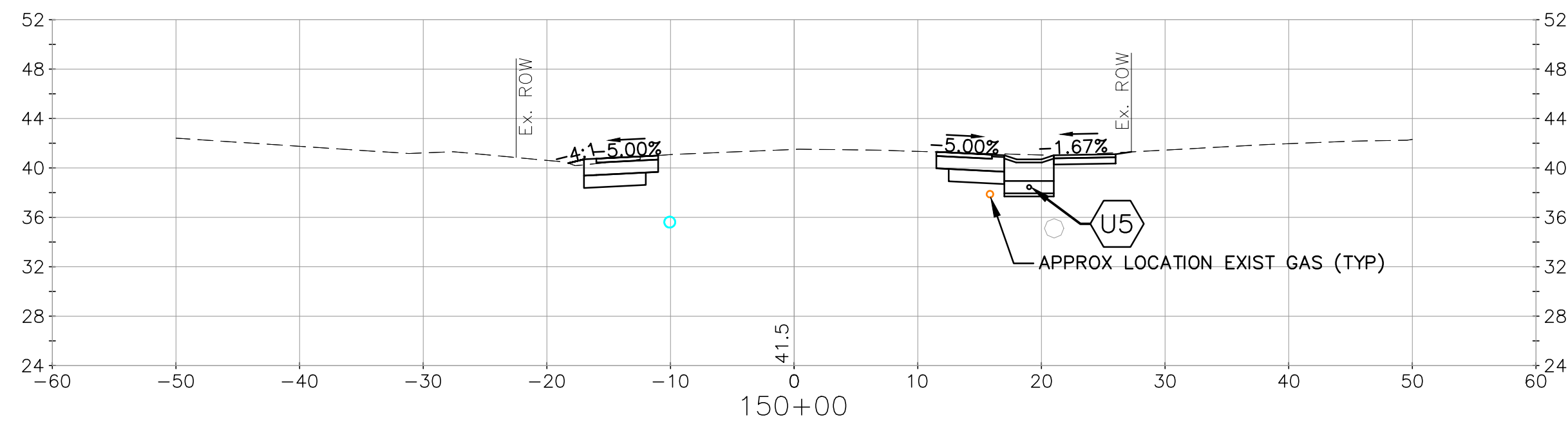
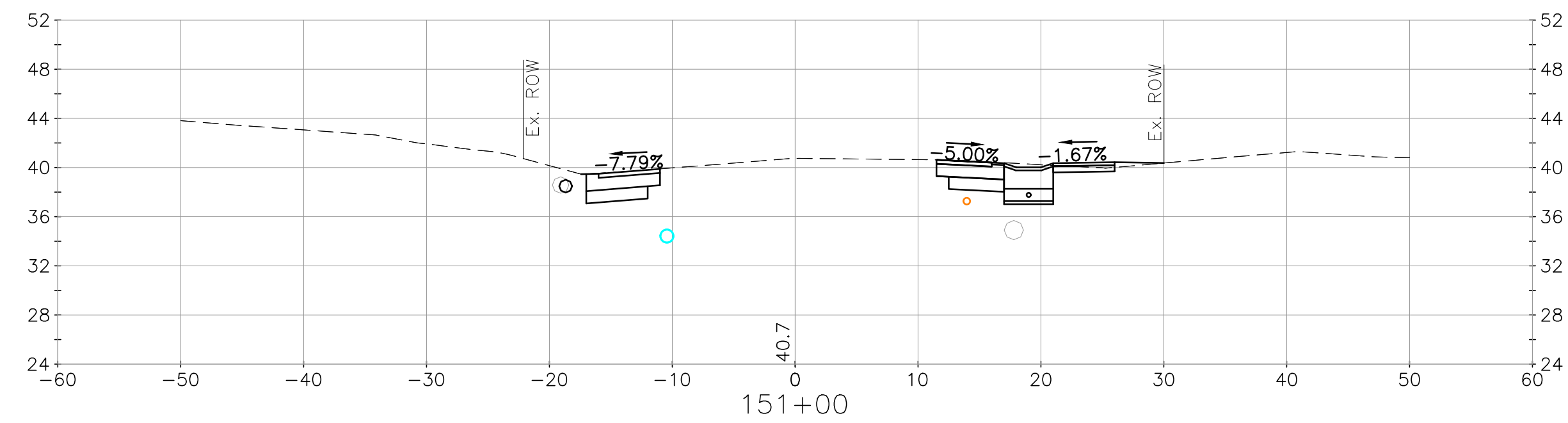
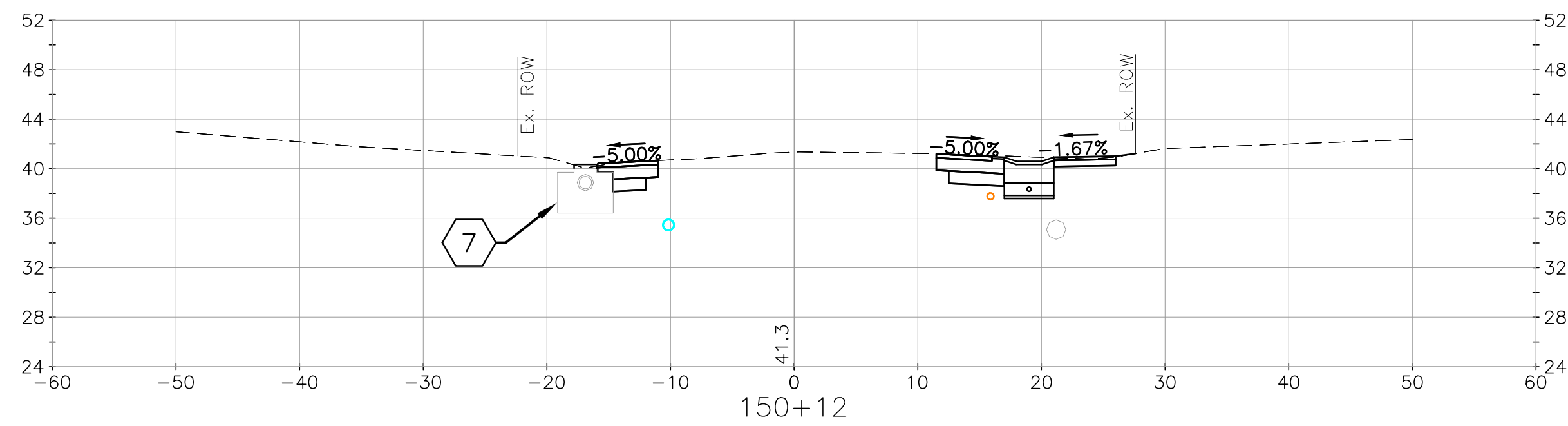
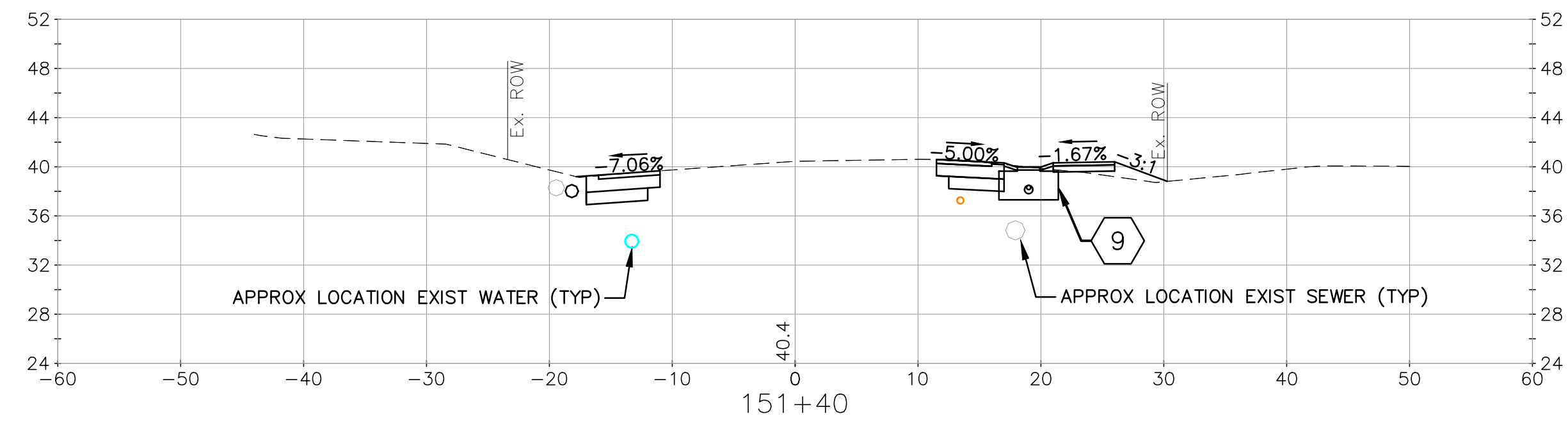
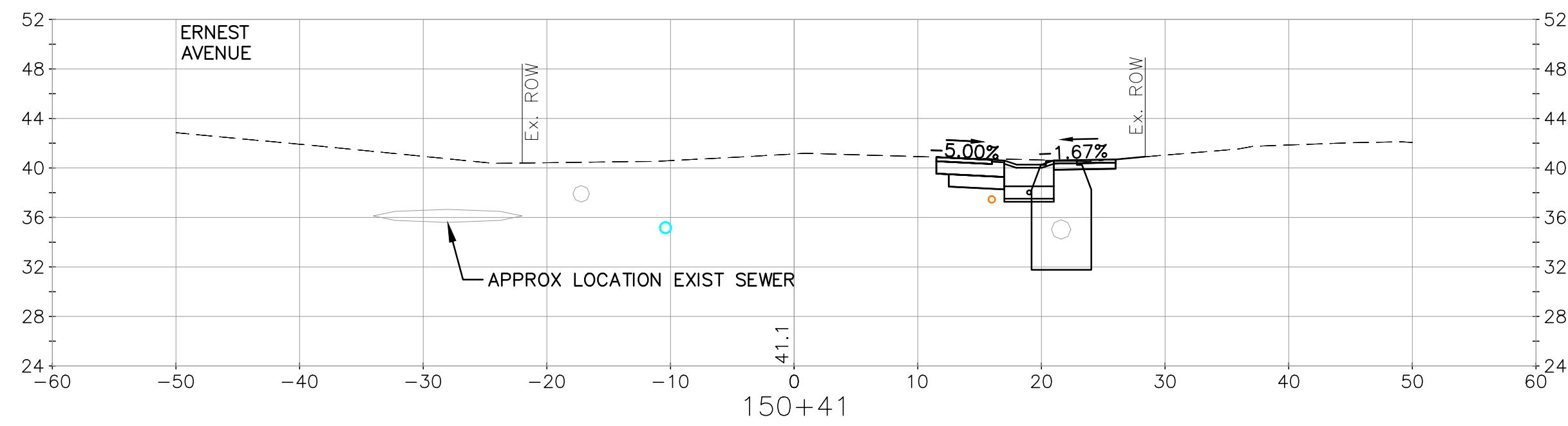
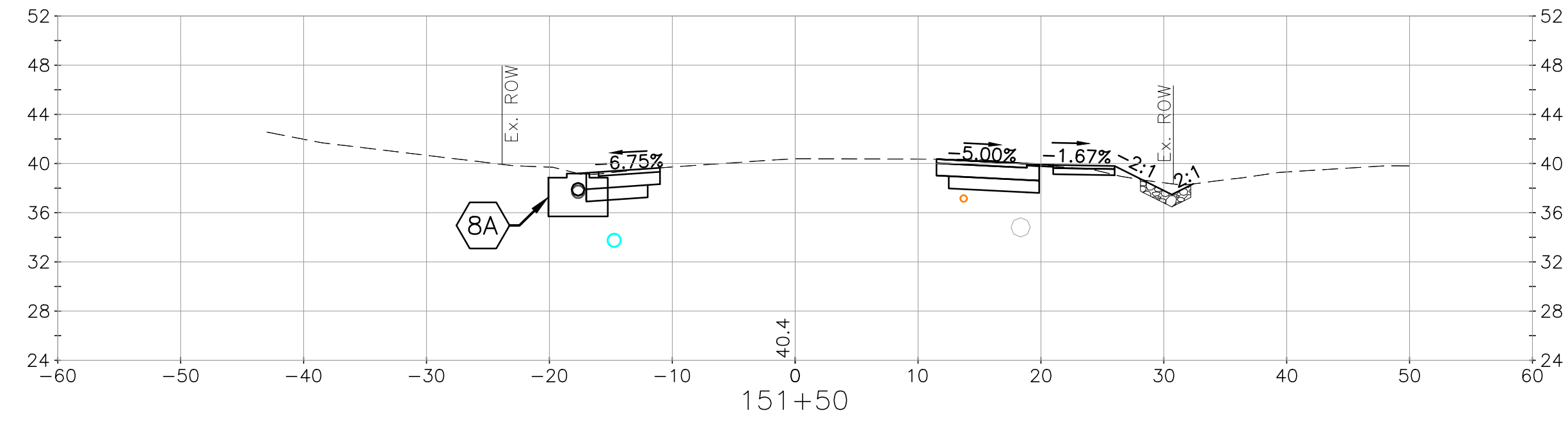
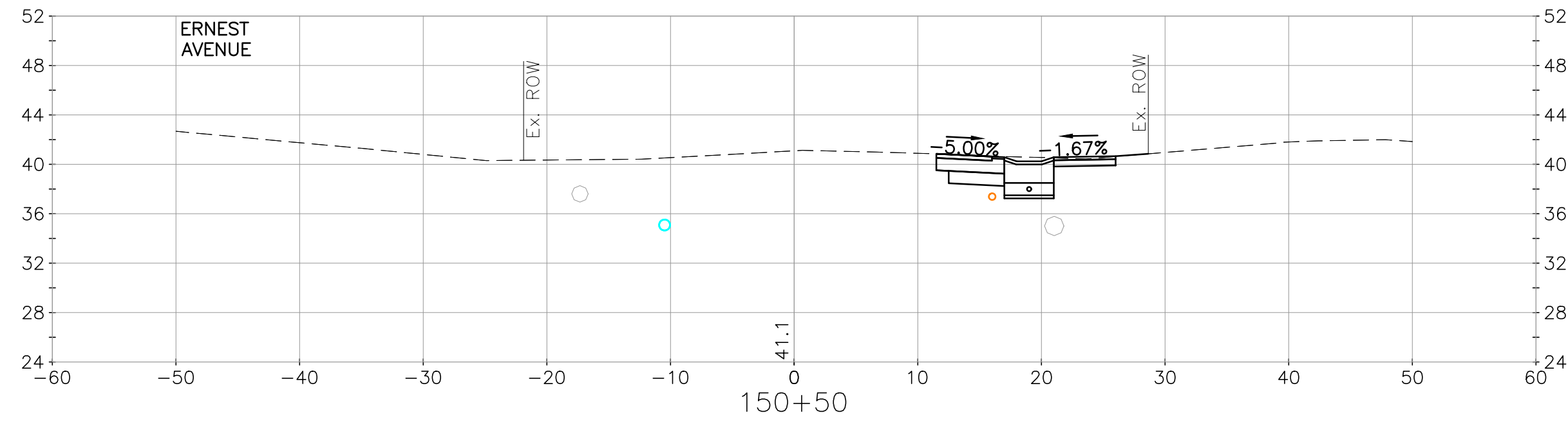

no.	1	Issued for Bidding	date	4/3/2023	by	JJB
revision						

CMA ENGINEERS
 CIVIL/ENVIRONMENTAL/STRUCTURAL
 Portsmouth, NH • Manchester, NH • Portland, ME
 603/431-6196 • 603/627-0708 • 207/541-4223
 c m a e n g i n e e r s . c o m



date:	April 2023	designed by:	JJB/STF
project no.:	1030	drawn by:	ATP/STF
file name:	1030-Sections.dwg	approved by:	JJB

Scale: 1" = 10'
 Scale: 1" = 20'

Town of Exeter, New Hampshire
 Public Works Department
 Kingston Road TAP Project
 Exeter 40436, X-A004(406)
 Cross Sections
 STA 150+00 to STA 151+50

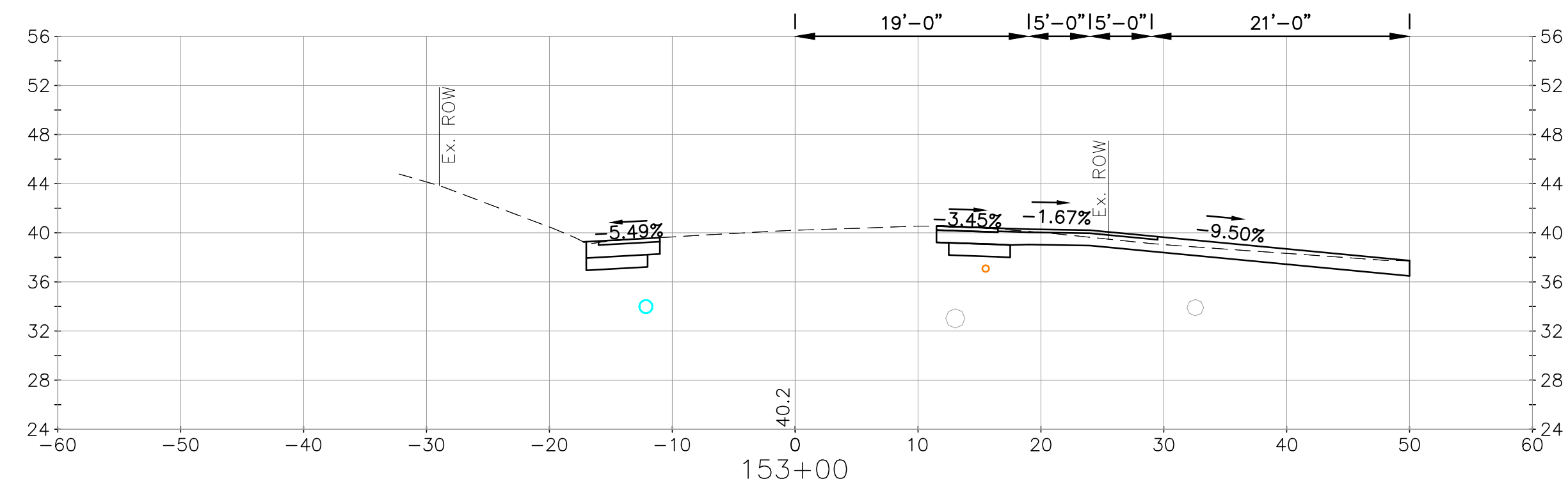
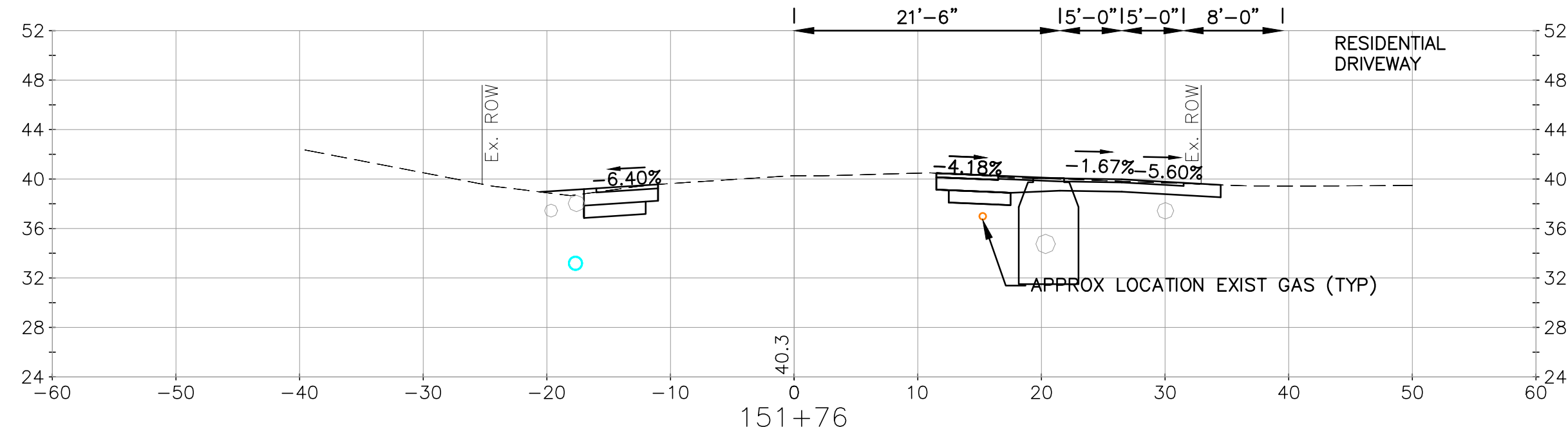
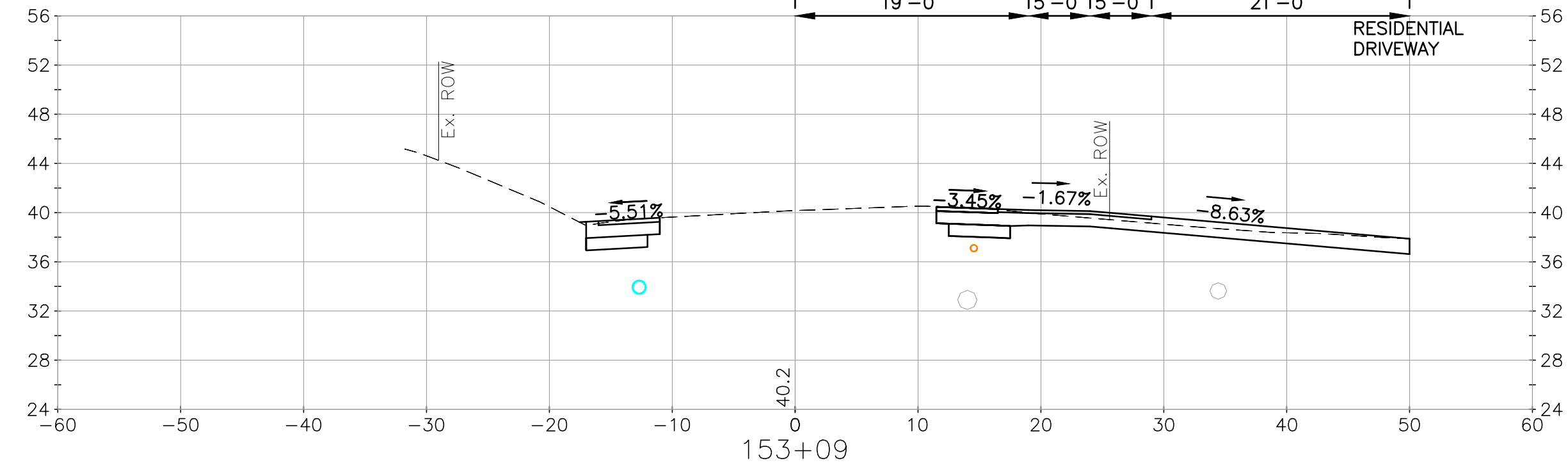
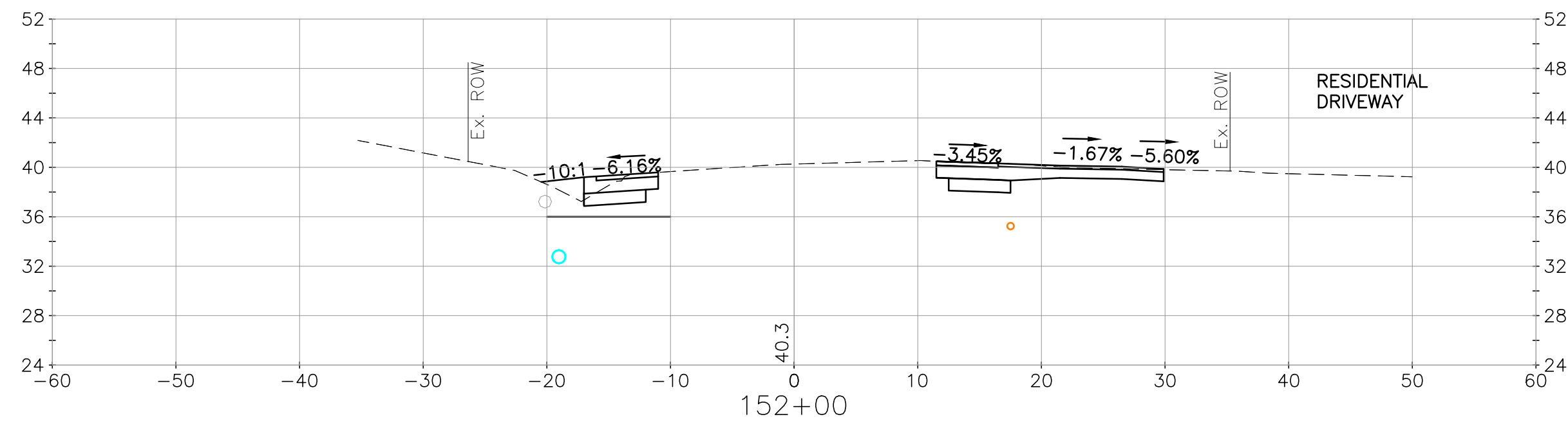
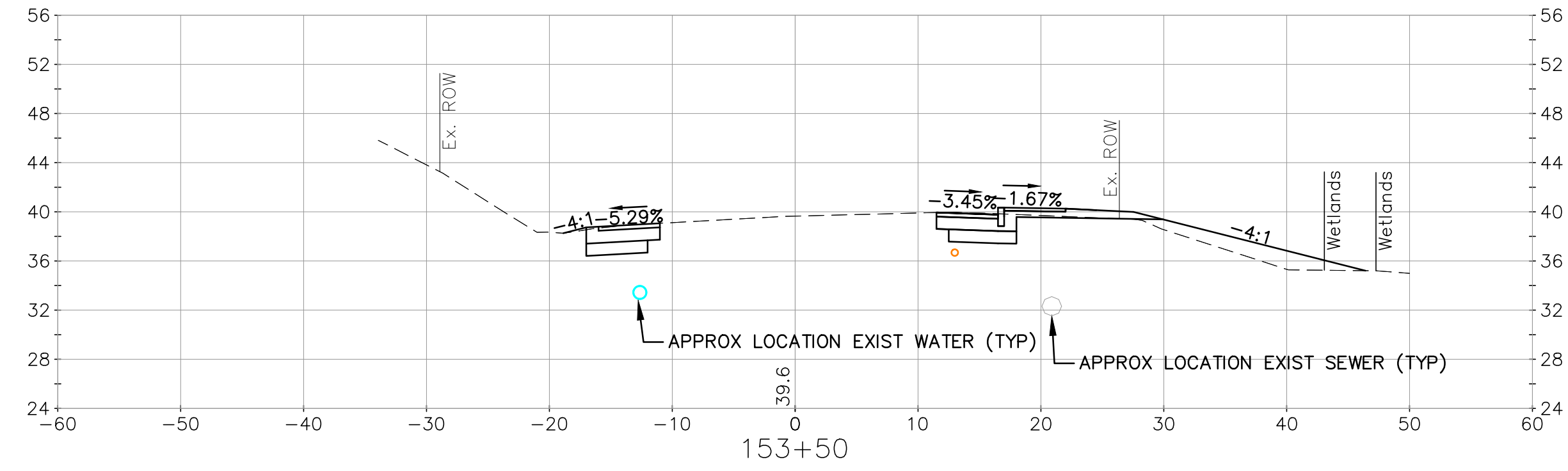
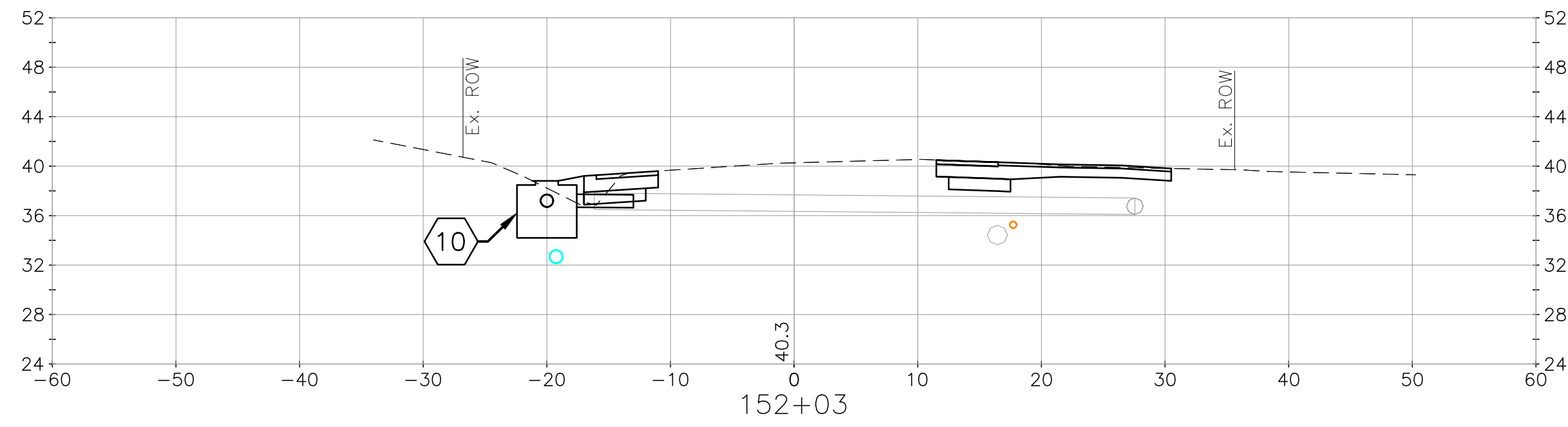
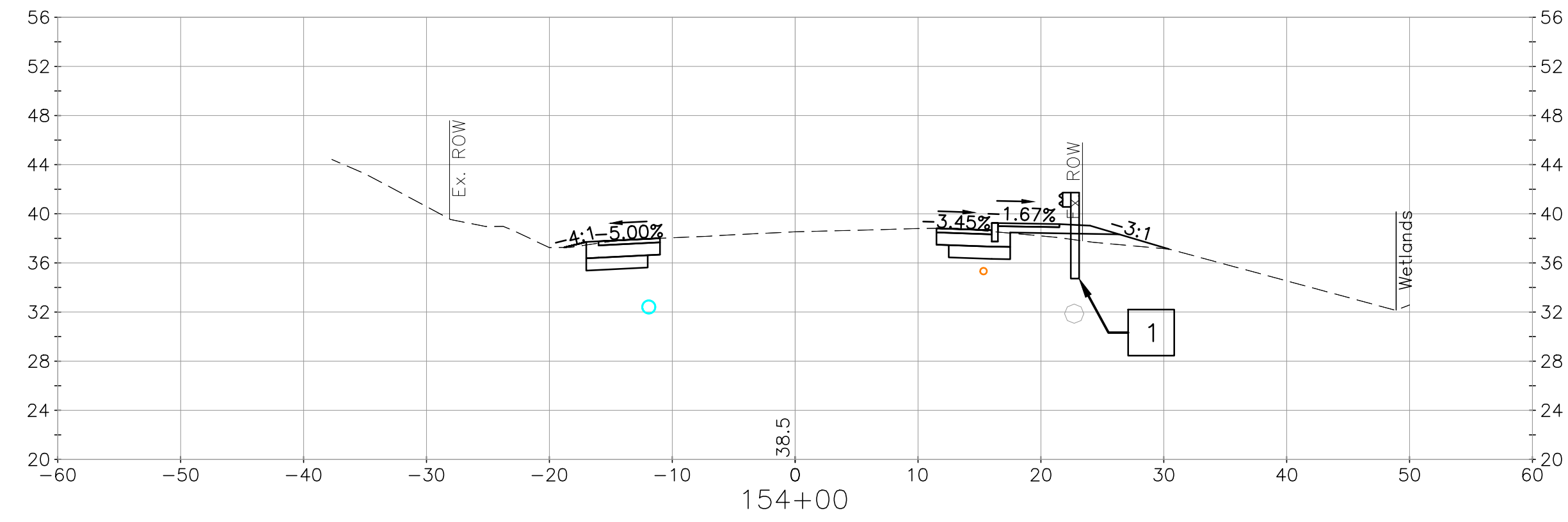
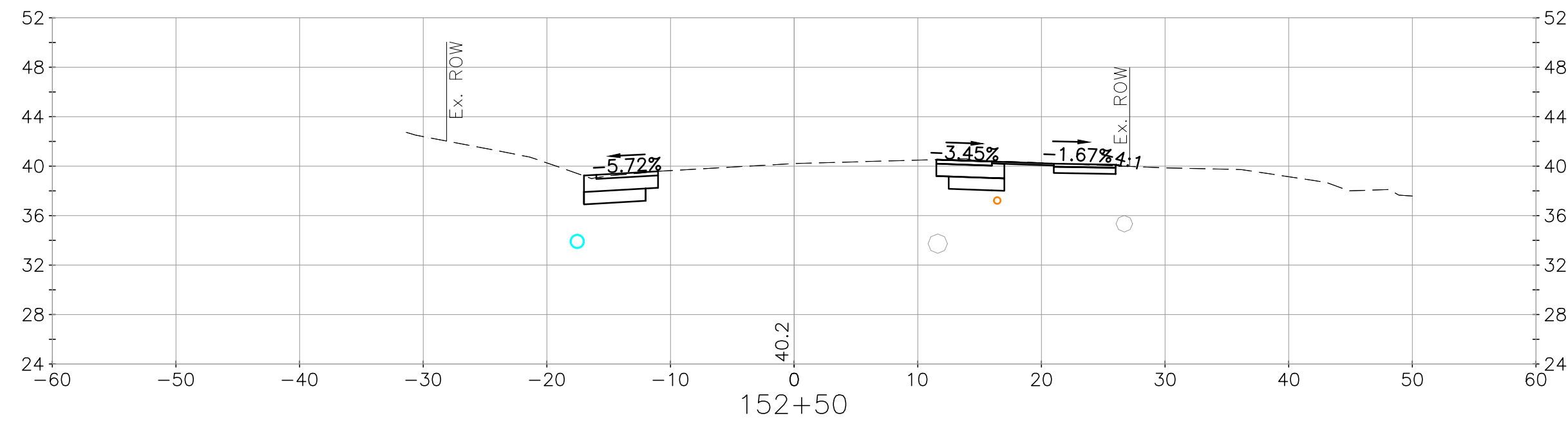

by	JJB
date	4/3/2023
revision	
no.	1
Issued for Bidding	

CMA ENGINEERS
 CIVIL/ENVIRONMENTAL/STRUCTURAL
 Portsmouth, NH • Manchester, NH • Portland, ME
 603/431-6196 • 603/627-0708 • 207/541-4223
 c m a e n g i n e e r s . c o m

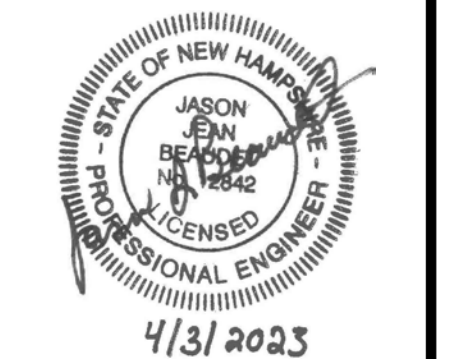

date:	April 2023
designed by:	JJB/STF
project no.:	1030
drawn by:	ATP/STF
file name:	1030-Sections.dwg
approved by:	JJB

scale: 1" = 10'
 0 10' 20'

Town of Exeter, New Hampshire
 Public Works Department
 Kingston Road TAP Project
 Exeter 40436, X-A004(406)
 Cross Sections
 STA 151+76 to STA 154+00

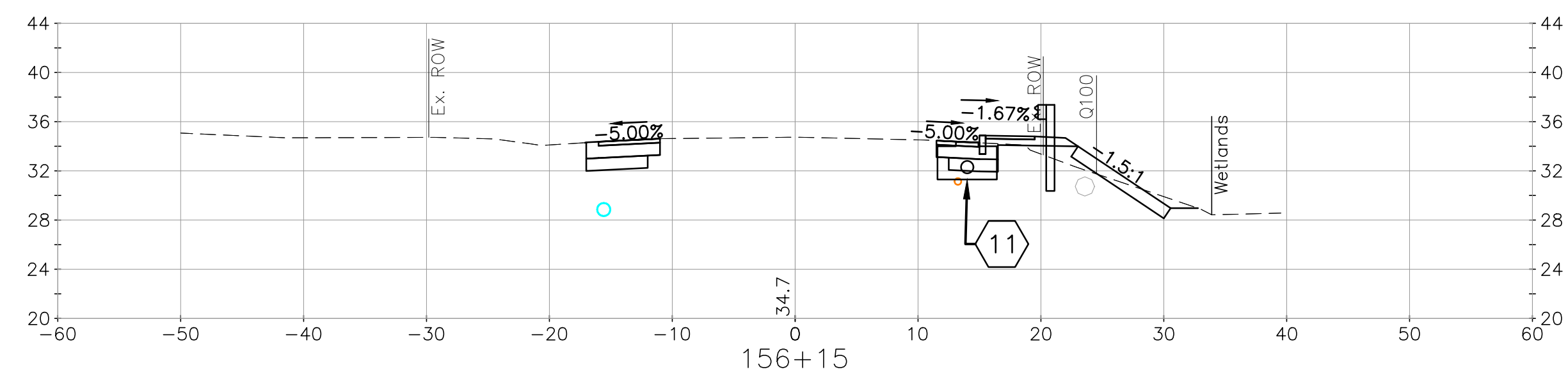
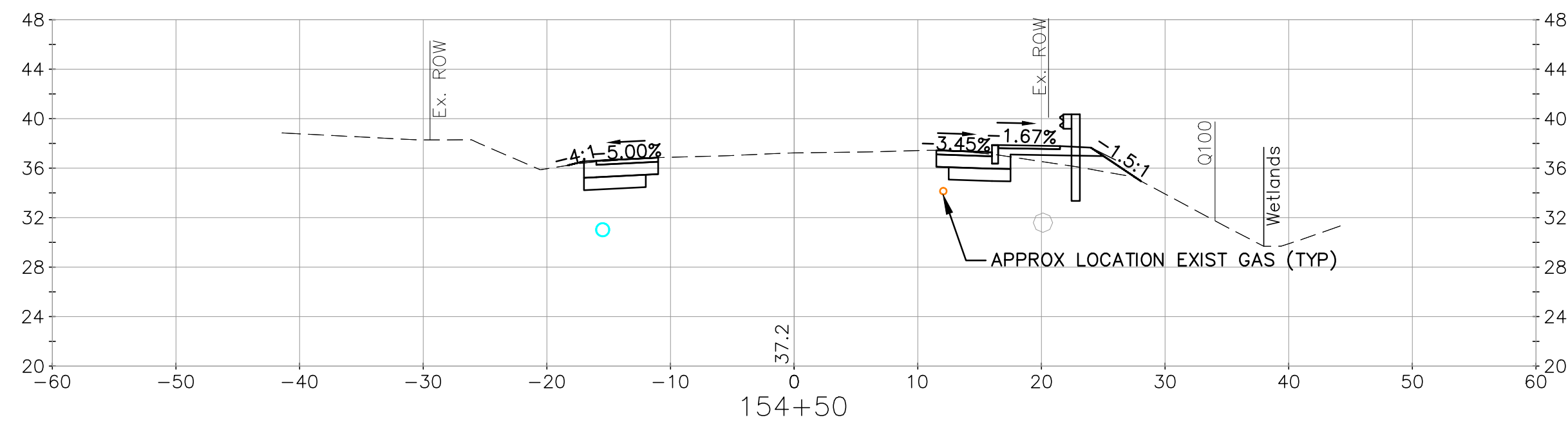
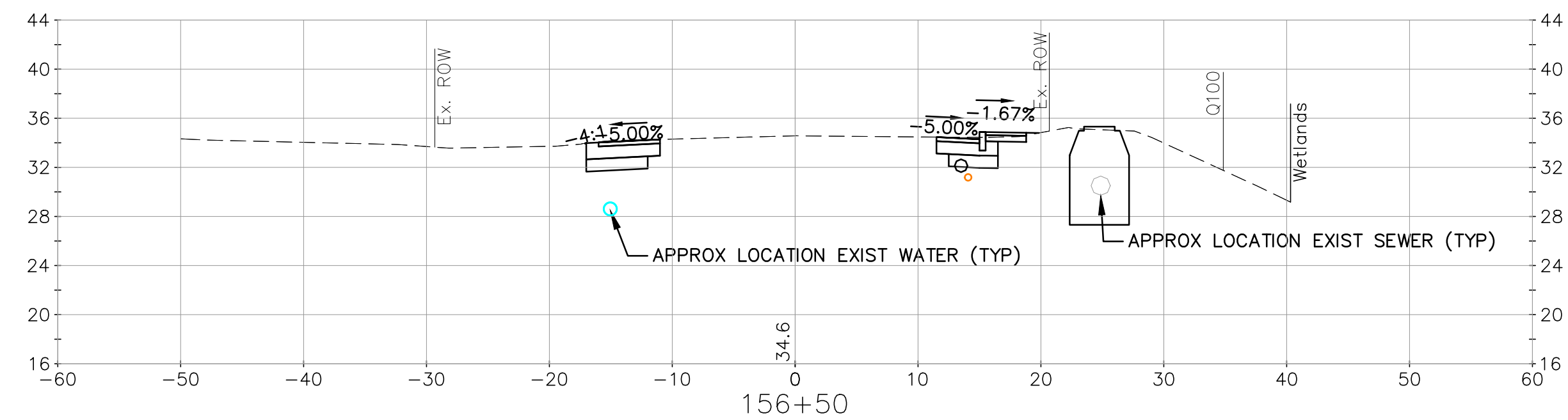
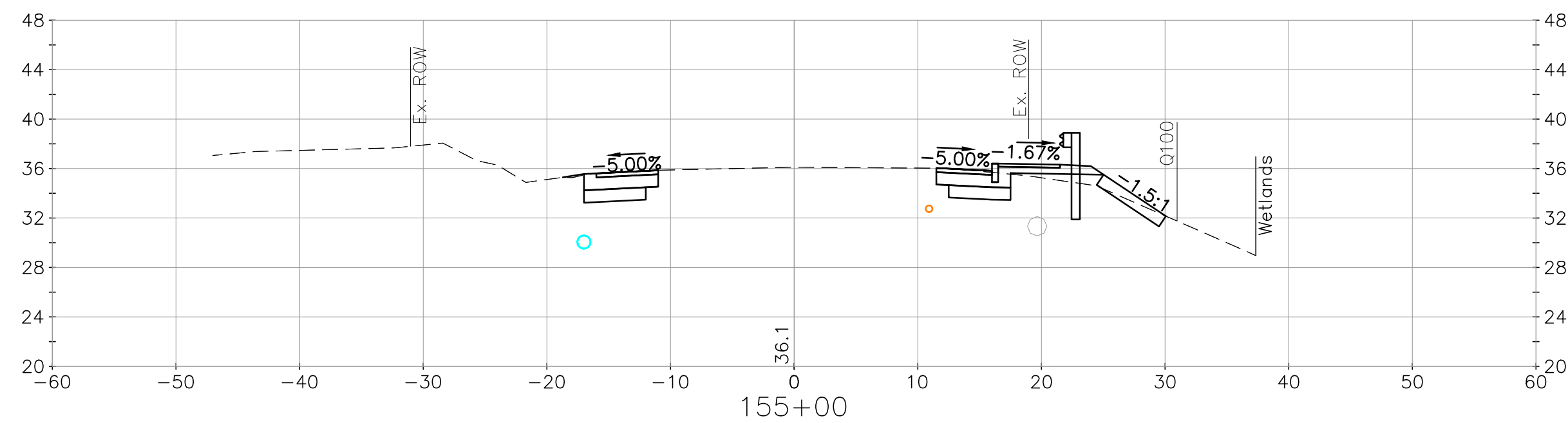
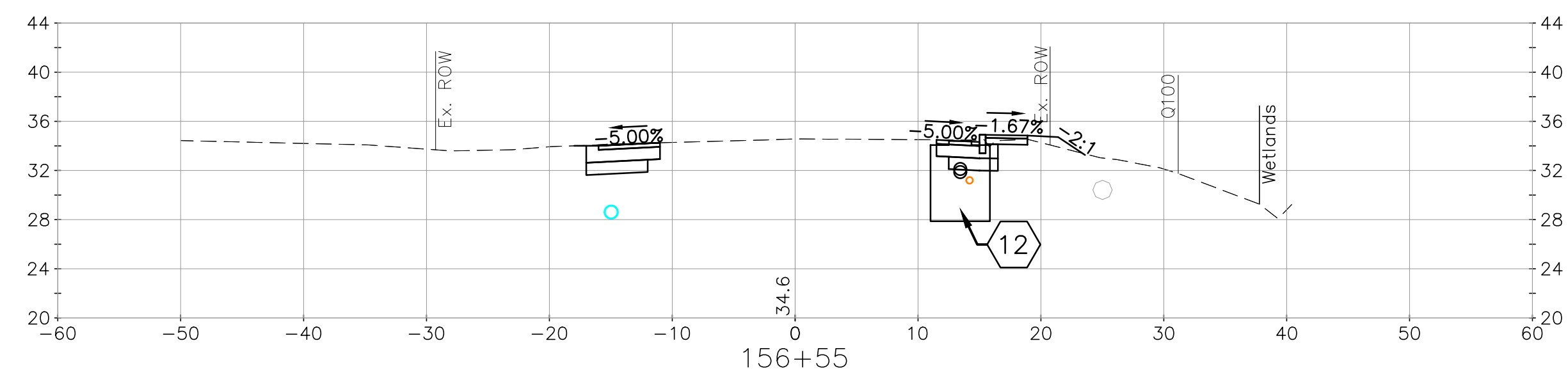
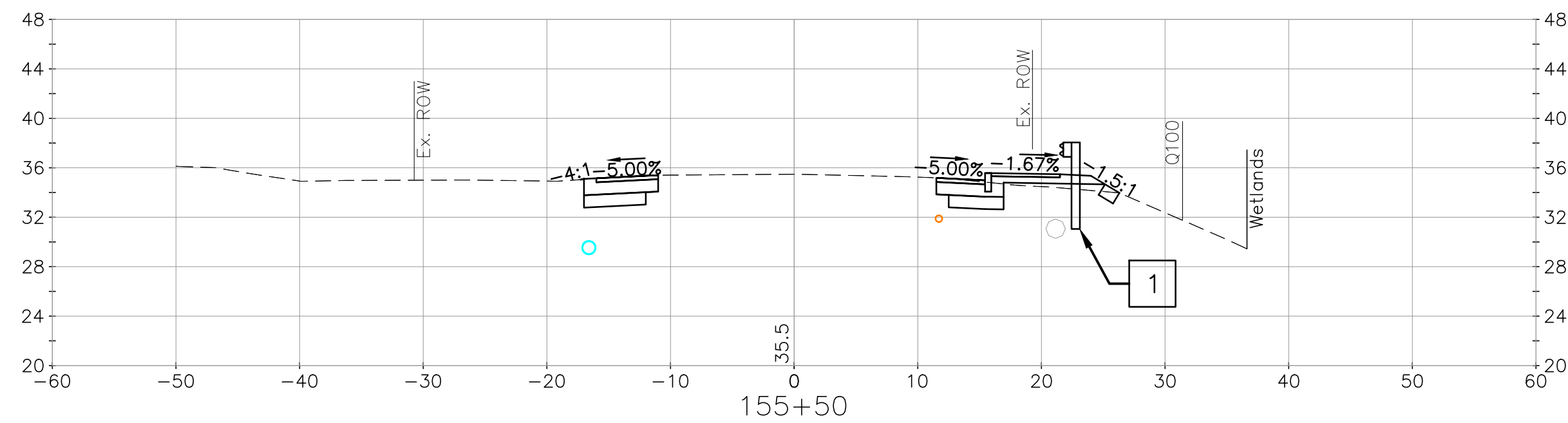
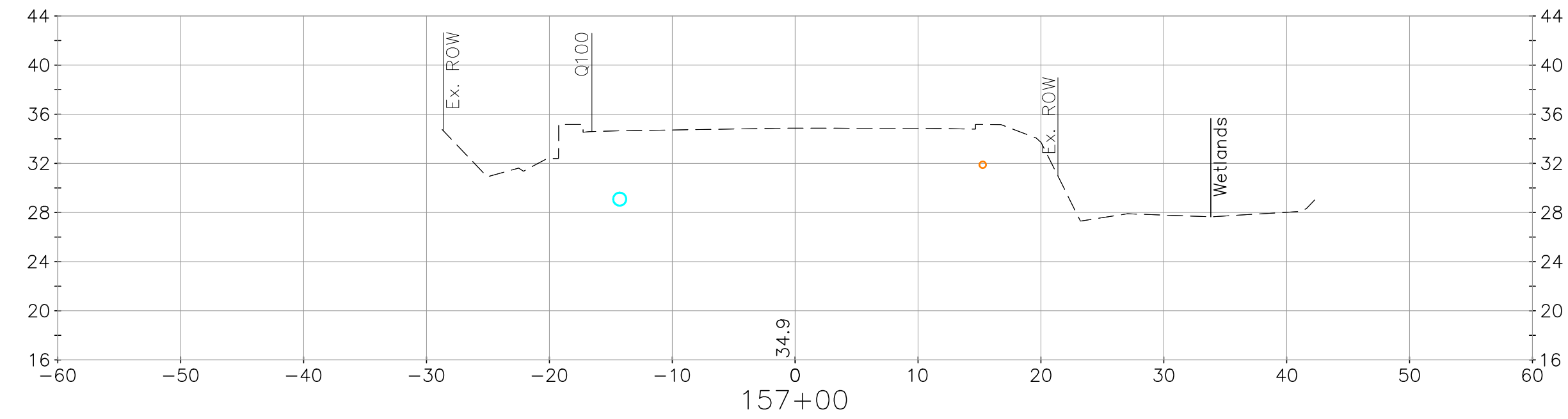
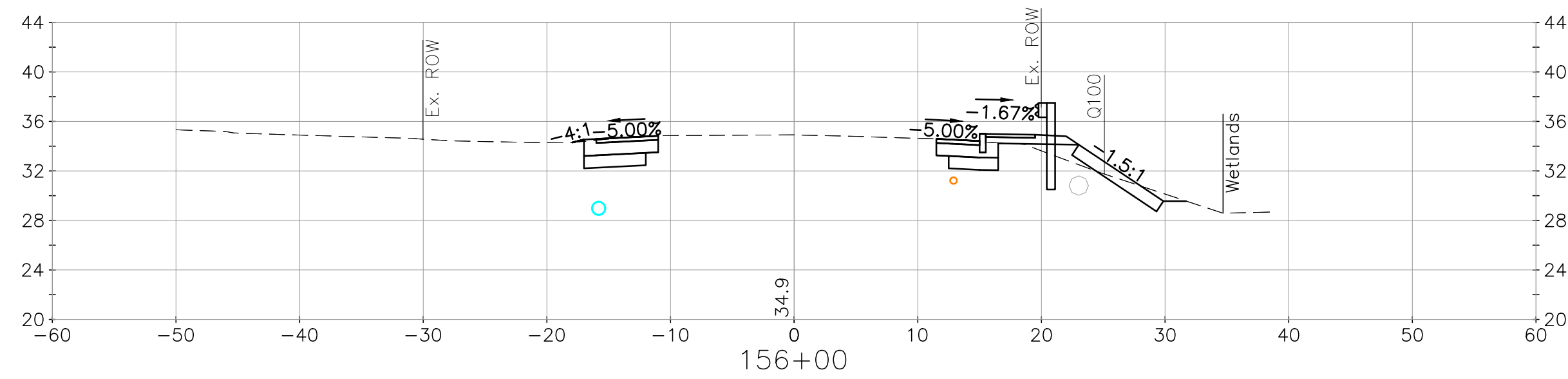

no.	1	Issued for Bidding	4/3/2023	JJB	by
revision					

CMA ENGINEERS
 CIVIL/ENVIRONMENTAL/STRUCTURAL
 Portsmouth, NH • Manchester, NH • Portland, ME
 603/431-6196 • 603/627-0708 • 207/541-4223
 c m a e n g i n e e r s . c o m

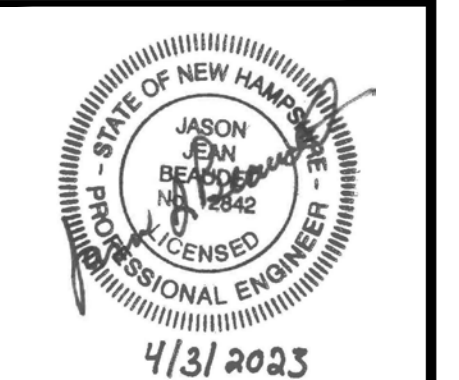

date:	April 2023	designed by:	JJB/STF
project no.:	1030	drawn by:	ATP/STF
file name:	1030-Sections.dwg	approved by:	JJB

scale: 1" = 10'
 0 10' 20'

Town of Exeter, New Hampshire
 Public Works Department
 Kingston Road TAP Project
 Exeter 40436, X-A004(406)
 Cross Sections
 STA 154+50 to STA 157+00